

S O L A C E



Listed Certified for USA. and Canada

Model Numbers MQHBZDV3636, MQHBZDV4236, MQHBZDV4736

Stock #'s: MQHBZDV3636N, MQHBZDV3636LP, MQHBZDV4236N, MQHBZDV4236LP, are Certified to: ANSI Z21.88b-2003, CSA-2.33b-2003, CGA 2.17-M91, CSA P.4.1-02
MQHBZDV4736N, MQHBZDV4736LP, are Certified to ANSI Z21.50a-2000, CSA-2.22a-2000, CGA 2.17-M91, CSA P.4.1-02

This appliance may be installed in an aftermarket permanently located, manufactured home (USA only) or mobile home, where not prohibited by local codes.

This appliance is only for use with the type of gas indicated on the rating plate. This appliance is not convertible for use with other gases, unless a certified kit is used.

“Zero Clearance” Direct Vent Gas Fireplace



**Read this complete manual before beginning installation.
These instructions must be kept with the unit for future reference.**

FOR YOUR SAFETY

WARNING: If the information in these instructions are not followed exactly, a fire or explosion may result causing property damage, personal injury or loss of life.

Warning: Improper installation, adjustment, alteration, service or maintenance can cause property damage, personal injury or loss of life. Refer to this manual. Installation and service must be performed by a qualified installer, service agency or the gas supplier.

Do not store or use gasoline or other flammable vapors and liquids in the vicinity of this or any other appliance.

What To Do If You Smell Gas

Do not try to light any appliance.

Extinguish any open flame.

Do not touch any electrical switch.

Do not use any phone in your building.

Immediately call your gas supplier from a neighbour's phone.

If you can not reach your gas supplier, call the fire department.

A Division of R-Co. Inc.
2340 Logan Avenue
Winnipeg, Manitoba, Canada R2R 2V3
Ph: (204) 632-1962

PRE-INSTALLATION QUESTIONS and ANSWERS

Why does my fireplace or stove give off odor?

It is normal for your fireplace to give off some odor. This is due to the curing of the paint, adhesives, silicones and any undetected oil from the manufacturing process as well as the finishing materials used with the installations (e.g. marble, tile and the adhesives used to adhere this product to the walls can react with heat and cause odors).

It is recommended that you burn your gas fireplace or stove for a minimum of four hours at a time with the fan off after the curing of the paint has been completed. These odors can last upward to 40 hours of burn time, keep burning at a minimum of four hours per use until odors dissipate.

About curing of the paint

Your stove or fireplace has been painted with the highest quality silicone stove paint. This paint dries quickly in 15-20 minutes when first applied at the factory. However, due to the high temperature silicone components, the paint will cure when heat is applied to the appliance as it is first used. The following information **applies to the curing process** to get the paint fully hard and durable.

Fire the appliance four successive times for 10 minutes each firing and a 5 minute cool down between each. Be aware during log and firebox paint curing that a white deposit may be developing on the inside of the glass doors. It is important to remove this white deposit from the glass doors with an appropriate cleaner to prevent build-up (such as Windex or a commercial fireplace glass cleaner).

- Babies, small children, pregnant women and pets should leave the area during the cure phase.
- Ventilate well, open doors and windows.
- Do not touch during curing.

Noise coming from the fireplace?

- Noise caused by metal expanding and contracting as it heats up and cools down, similar to the sound produced by a furnace or heating duct. This noise does not affect the operation or longevity of your fireplace.

Table of Contents

Mobile Home/Manufactured Housing Installation	4
Installation and operation	5
Installation Requirements for the Commonwealth of Massachusetts	6
MQHBZDV3636	
Locating your appliance	7
Fireplace Dimensions	7
Framing your gas fireplace	8
Framing & Facing Requirements	9
Installing Clean View Kit (CVCK)	10
Clearances to Combustibles	10
Parts List	11
Kingsman Fireplace Venting	12
MQHBZDV4236	
Locating you appliance	13
Fireplace Dimensions	13
Framing your gas fireplace	14
Framing & Facing Requirements	15
Installing Clean View Kit (CVCK)	16
Clearances to Combustibles	16
Parts List	17
Kingsman Fireplace Venting	18
MQHBZDV4736	
Locating you appliance	19
Fireplace Dimensions	19
Framing your gas fireplace	20
Framing & Facing Requirements	21
Installing Clean View Kit (CVCK)	22
Clearances to Combustibles	22
Parts List	23
Kingsman Fireplace Venting	24
Clearance, Mantals & Surrounds	25-26
Dimensions & Installation of Wall Mount Surrounds	27
Fan Installation - MQHBZDV3636/4236/4736	28
Brick Installation - MQHBZDV3636/4236/4736	29
Gas Line Installation	30
Millivolt system, lighting, & burner control	31
Trouble shooting the gas control system	32
Burner System Removal - MQHBZDV3636/4236/4736	33
Gas Conversion - MQHBZDV3636/4236/4736	34
Installation of Gas Converstion Kit	35
Door and glass information	36
Log Placement Guide	37
Rock F2 Setup	38-39
Rock F1 Setup	40-41
Vent termination	42
General vent installation information	43
Venting graph	44
Installation of side wall venting	
- MQHBZDV3636/4236/4736	45
Vertical Venting	46
Limited Lifetime Warranty	47

Mobile Home/Manufactured Housing Installation

This Direct Vent System Appliance must be installed in accordance with the manufacturer's installation instructions and the Manufactured Home Construction and Safety Standard Title 24 CFR, Part 3280, or the current Standard for Fire Safety Criteria for Manufactured Home Installations, Sites, and Communities ANSI/NFPA 501A, and with CAN/CSA Z240 MH Mobile Home Standard in Canada.

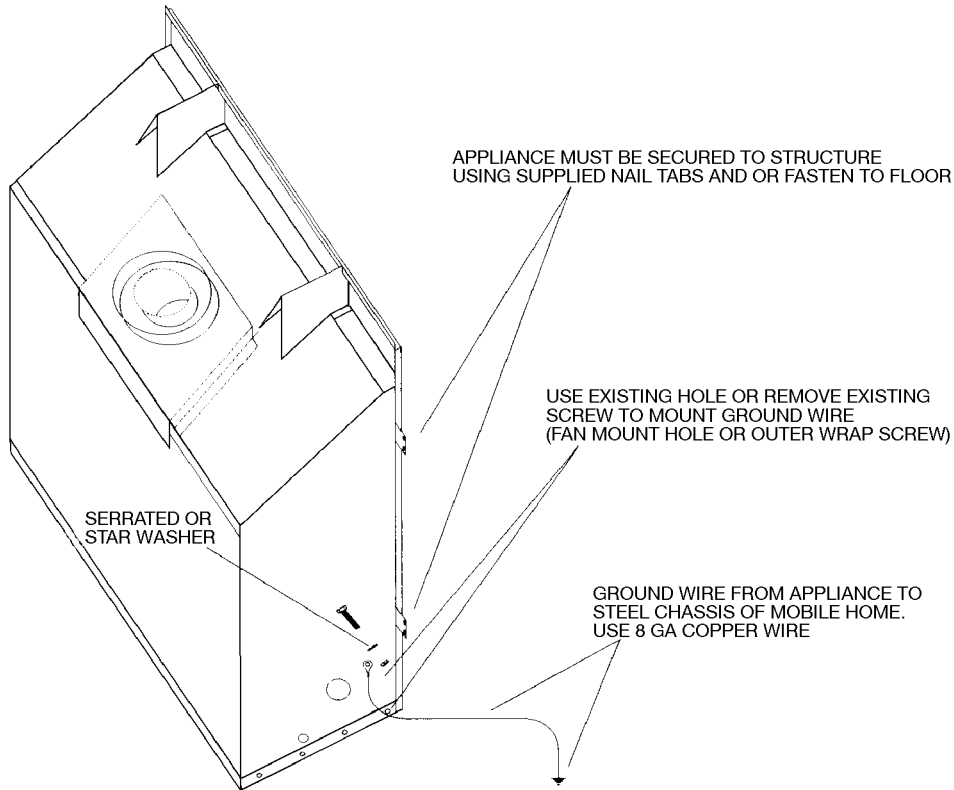

THE MQHBZDV3636N, MQHBZDV3636LP, MQHBZDV4236N and MQHBZDV4236LP MAY BE INSTALLED IN MANUFACTURED (MOBILE) HOMES AFTER FIRST SALE IN THE USA. IN CANADA THE MQHBZDV3636N, MQHBZDV3636LP, MQHBZDV4236N and MQHBZDV4236LP MAY BE INSTALLED IN MANUFACTURED (MOBILE) HOMES.

Please follow the current ANSI/NFPA 70 National Electrical Code in the USA and CAN/CSA C22.1 Canadian National Electrical Code in Canada.

An appliance must be grounded to the steel chassis of the home with 8 ga. copper wire using a serrated or star washer to penetrate paint or protective coating to insure grounding.

Use carriage bolt at the attachment point (see diagram above) to secure the appliance to the floor.

Warning: Do not compromise the structural integrity of the manufactured home wall, floor or ceiling, during installation of appliance or venting.

For required venting components see venting installation in appropriate section of this manual.

Certified for installation in a bedroom or bedsitting room. In Canada must be installed with listed milli volt thermostat. In USA see local codes.

Installation and Operation

Installation Regulations

This gas appliance must be installed by a qualified installer in accordance with local building codes, or in the absence of local codes, with the current CAN/CGA-B149.1 or .2 Installation Code (in Canada) or the current National Fuel Gas Code Z223.1 when installed in the United States.

This appliance, when installed, must be electrically connected and grounded in accordance with local codes, or in the absence of local codes, with the current CSA C22.1 Canadian Electrical Code or with the national Electrical Code; ANSI/NFPA 70-1987 when installed in the United States.

Vertical Venting in Cold Climates

In cold climate conditions where temperatures go below -10 degrees Celsius or 14 degrees Fahrenheit, we recommend that the chase be insulated and where the vent pipe enters into the attic space that the pipe be wrapped with an insulated mylar sleeve. This will increase the temperature of the vent and help the appliance to vent properly in cold weather conditions.

It is also important in vertical vented direct vent appliances that the appliance be operated daily during the winter months as this will help stop the Termination from freezing up. We recommend using a thermostat set at room temperature to allow the unit to cycle.

FOR SAFE INSTALLATION AND OPERATION OF YOUR GAS FIREPLACE PLEASE NOTE THE FOLLOWING:

1. This appliance gives off high temperatures and should be located out of heavy traffic areas and away from furniture and draperies.
2. Children and adults should be alerted to the hazards of the high surface temperatures of this appliance and should stay away to avoid burns or ignition of clothing.
3. Children should be carefully supervised when they are in the same room as your fireplace appliance.

NOTE: It is recommended that a Carbon Monoxide (CO) Detector be installed in or near bedrooms and on all levels of your home. Place a detector about 15 feet (4.5 meters) outside the room that houses your gas appliance.

Warning: When purging the gas line, the glass front must be removed.

Never use your gas fireplace as a cooking device.

The Burner/Log Assembly has been engineered and permanently adjusted for proper flame control.

Do not alter gas orifice.

4. Under no circumstances should this appliance be modified. Any parts that have to be removed for servicing should be replaced prior to operating this appliance.
5. Installation and repair should be done by a qualified service person. The appliance should be inspected before use and at least annually by a professional service person. More frequent cleaning may be required due to excessive lint from carpeting, bedding material, et cetera. It is imperative that control compartments, burners and circulating air passageways of the appliance be kept clean.
6. Control compartments, burners and air passages in this appliance should be kept clean and free of dust and lint. Make sure that the gas valve and pilot light are turned off before you attempt to clean this unit.
7. The venting system (chimney) of this appliance should be inspected at least once a year and if needed, your venting system should be cleaned.
8. Clothing or other flammable material should not be placed on or near the appliance. This appliance should not be used as a drying rack for clothing nor should Christmas stockings or decorations be hung from it.
9. Under no circumstances should any solid fuels (wood, paper) be used in this appliance.
10. For safe operation, glass doors must be closed.
11. Do not use this heater if any part has been under water. Immediately call a qualified service technician to inspect the heater and to replace any part of the control system and any gas control which has been under water.
12. **WARNING:** Do not operate appliance with the glass front removed, cracked or broken. Replacement of glass should be done by a licensed or qualified service person.
13. Do not operate appliance unless completely installed as per installation instructions.
14. In the Commonwealth of Massachusetts a CO detector must be installed in the same room as the appliance.
15. Gas fired appliances may be used only for supplemental heat and/or decorative purposes and under no circumstances shall they provide a primary heat source.

Periodically remove the logs from the grate assembly and vacuum any loose particles from the grate and burner areas.

See log/rock placement on pages 36-40 to remove logs, vacuum burner parts and replace logs.

Note: It is normal for your gas fireplace to give off some odor the first time it is burned. This is due to the curing of the paint and any undetected oil from the manufacturing process.

Please ensure that your room is well ventilated - open all windows. It is recommended that you burn your gas fireplace for at least four (4) hours the first time you use it without the fan on.

Make adequate accessibility clearances for servicing and proper operation.

This appliance must not be connected to a chimney flue serving a separate solid fuel burning appliance.

Be sure that the flow of combustion and ventilation air is not obstructed.

Installation Requirements for the Commonwealth of Massachusetts

In the Commonwealth of Massachusetts, the installer or service agent shall be a plumber or gas fitter licensed by the Commonwealth.

When installed in the Commonwealth of Massachusetts or where applicable codes; the unit shall be installed with a CO detector per the requirements listed below.

1. For direct-vent appliances, mechanical-vent heating appliances or domestic hot water equipment, where the bottom of the vent terminal and the air intake is installed below four feet above grade the following requirements must be satisfied:
 - A. If there is not one already present, on each floor level where there are bedroom(s), a carbon monoxide detector and alarm shall be placed in the living area outside the bedroom(s). The carbon monoxide detector shall comply with NFPA 720 (2005 Edition).
 - B. A carbon monoxide detector shall be located in the room that houses the appliance or equipment and shall:
 - a. Be powered by the same electrical circuit as the appliance or equipment such that only one service switch services both the appliance and the carbon monoxide detector;
 - b. Have battery back-up power;
 - c. Meet ANSI/UL 2034 Standards and comply with NFPA 720 (2005 Edition); and
 - d. Have been approved and listed by a Nationally Recognized Testing Laboratory as recognized under 527 CMR.
 - C. A Product-approved vent terminal must be used, and if applicable, a Product-approved air intake must be used. Installation shall be in strict compliance with the manufacturer's instructions. A copy of the installation instructions shall remain with the appliance or equipment at the completion of the installation.
 - D. A metal or plastic identification plate shall be mounted at the exterior of the building, four feet directly above the location of vent terminal. The plate shall be of sufficient size to be easily read from a distance of eight feet away, and read "Gas Vent Directly Below".
2. For direct-vent appliances, mechanical-vent heating appliances or domestic hot water equipment where the bottom of the vent terminal and the air intake is installed above four feet above grade the following requirements must be satisfied:
 - A. If there is not one already present, on each floor level where there are bedroom(s), a carbon monoxide detector and alarm shall be placed in the living area outside the bedroom(s). The carbon monoxide detector shall comply with NFPA 720 (2005 Edition).
 - B. A carbon monoxide detector shall:
 - a. Be located in the room that houses the appliance or equipment;
 - b. Be either hard-wired or battery powered or both; and
 - c. Shall comply with NFPA 720 (2005 Edition).
 - C. A Product-approved vent terminal must be used, and if applicable, a Product-approved air intake must be used. Installation shall be in strict compliance with the manufacturer instructions. A copy of the installation instructions shall remain with the appliance or equipment at the completion of the installation.

MQHBZDV3636 - Locating your Appliance

Installing with Top Vent

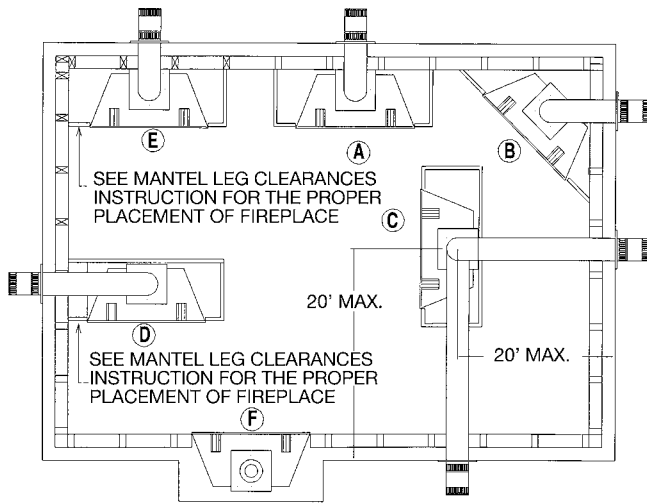

- A - Flat on a wall
- B - Across the corner
- C - As an island
- D - As a room divider
- E - Flat on wall corner
- F - Exterior wall

Island installation with a top vent is possible as long as the horizontal portion of the vent system does not exceed 20 feet (6.1 m).

Fireplace Dimensions

MQHBZDV36 louvered

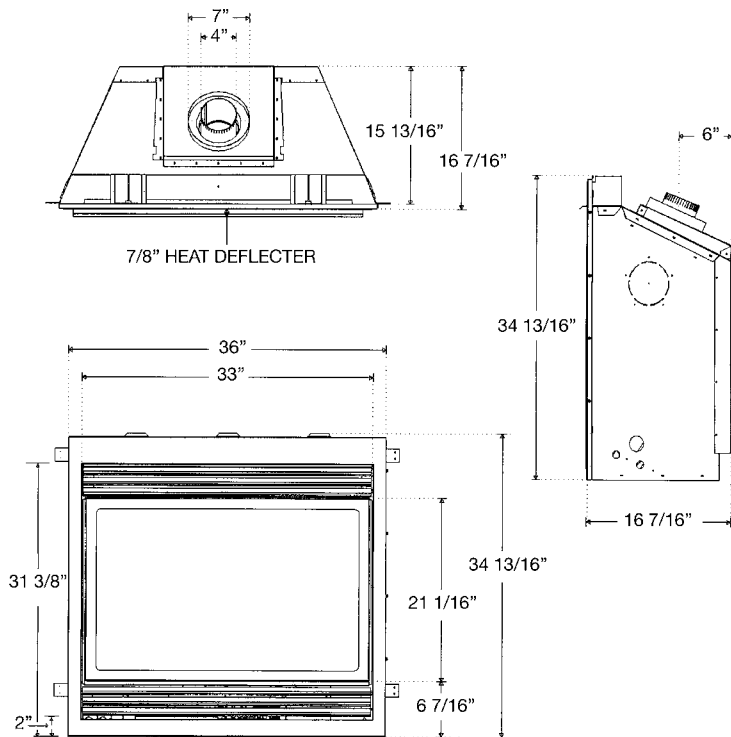

MQHBZDV36 -CVCK (Clean View Circulating Kit)

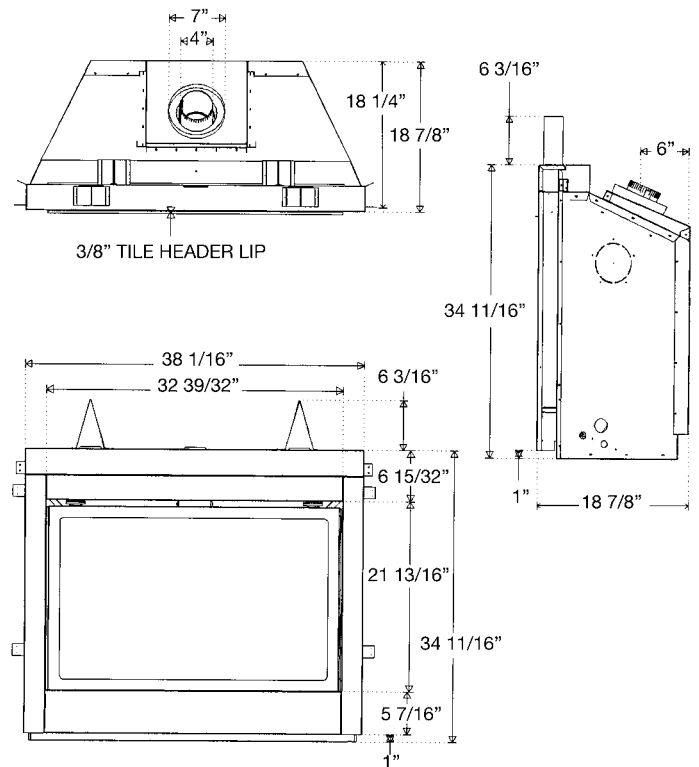

MQHBZDV3636 - Framing for your Gas Fireplace

Framing Specifications

1. Cold climate installation recommendation: When installing this fireplace against non insulated exterior wall or chase, it is recommended that the outer walls be insulated to conform to applicable insulation codes. Drywall must be installed over insulation to prevent contact of insulation and unit.
2. Choose fireplace location and frame in accordance with the fireplace framing dimensions specified (See Framing Diagrams). Bend nailing tabs forward on left and right of unit and place fireplace into framed enclosure. This allows for 1/2" in front of framing tabs for finishing materials.
3. Drywall or other material can extend flush with the appliance on the bottom, sides and top of fireplace. (louvered models only)
4. When installing horizontal with a 90 degree bend maintain a minimum of two and a half (2.5") inches above the bend in enclosures.
5. For a fireplace with louvers combustible floor can raise 1" above the bottom of the fireplace. For a fireplace with HB36CVCK (Clean view Circulating Kit) floor or hearth can raise 7" above the bottom of the fireplace with portions being combustible and non combustible. See drawing on following page.
6. When installing MQHB36SW surround, the fireplace must be raised a minimum of 3 1/2" above the finished floors, to accommodate the wall surround. The fireplace may be raised higher but the 60" clearance measured from the bottom of the fireplace to the ceiling must be maintained at all times. (i.e. For an 8 ft. ceiling the unit can be raised only 36 inches.)

It is recommended for **Propane Horizontal Installations** that the venting should be a minimum of one foot vertical off the flue before the elbow on any horizontal runs of one foot or greater. This allows for cleaner combustion and greatly reduces carboning and cleaning of glass.

MQHBZDV36 Louvered

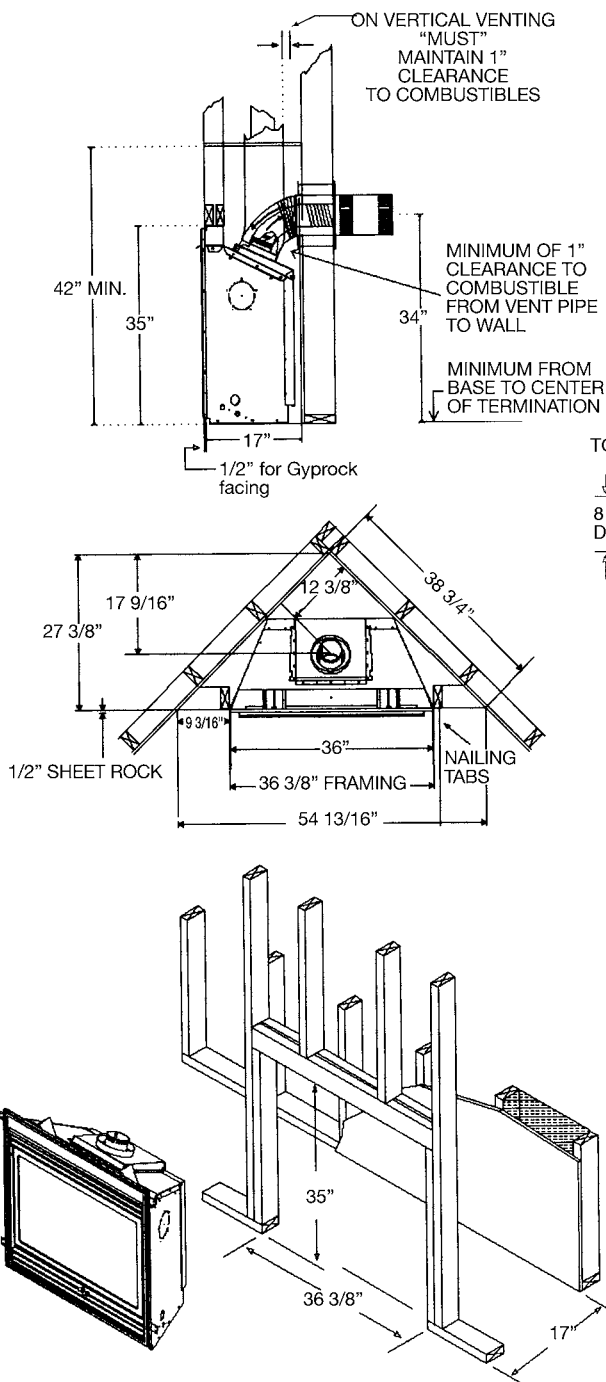

MQHBZDV36 WITH CVCK (CLEAN VIEW CIRCULATING KIT)

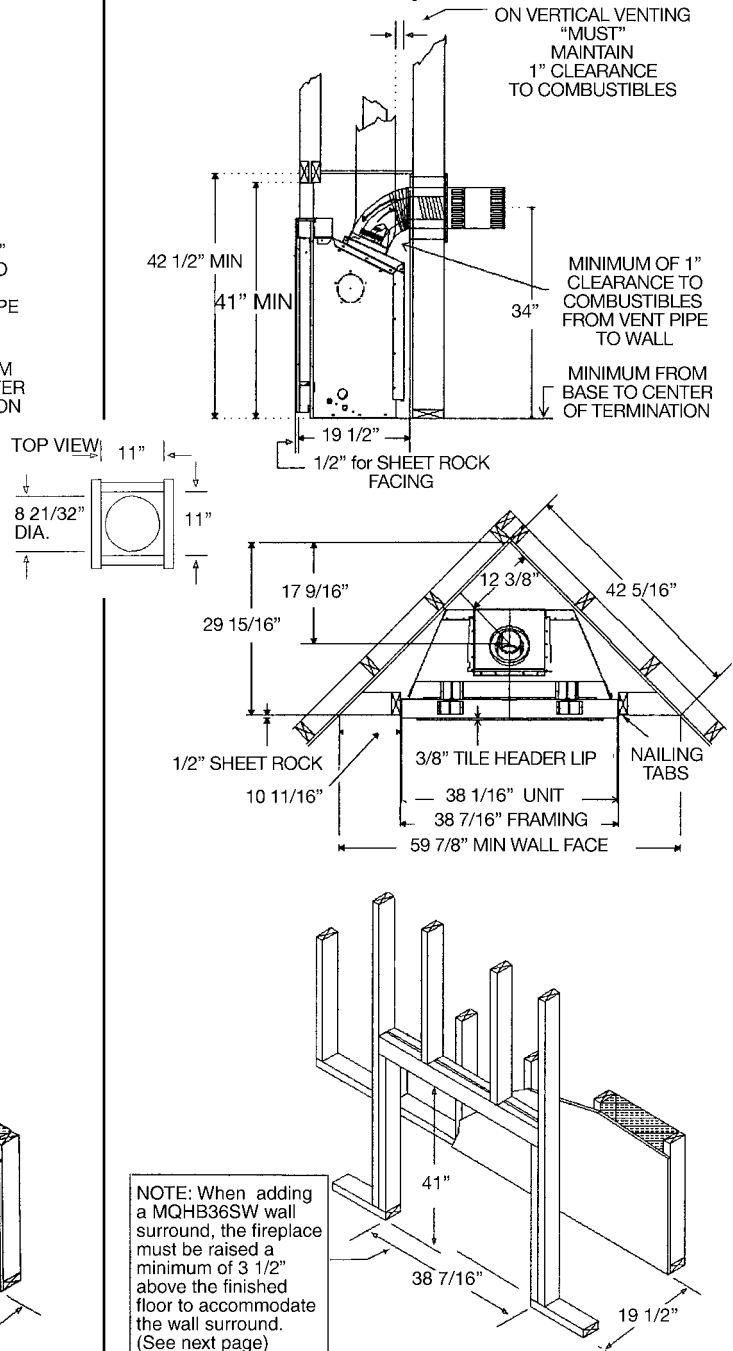

MQHBZDV3636 - Framing and Facing Requirements

HBZDV36 WITH HB36CVCK (CLEAN VIEW CIRCULATING KIT)

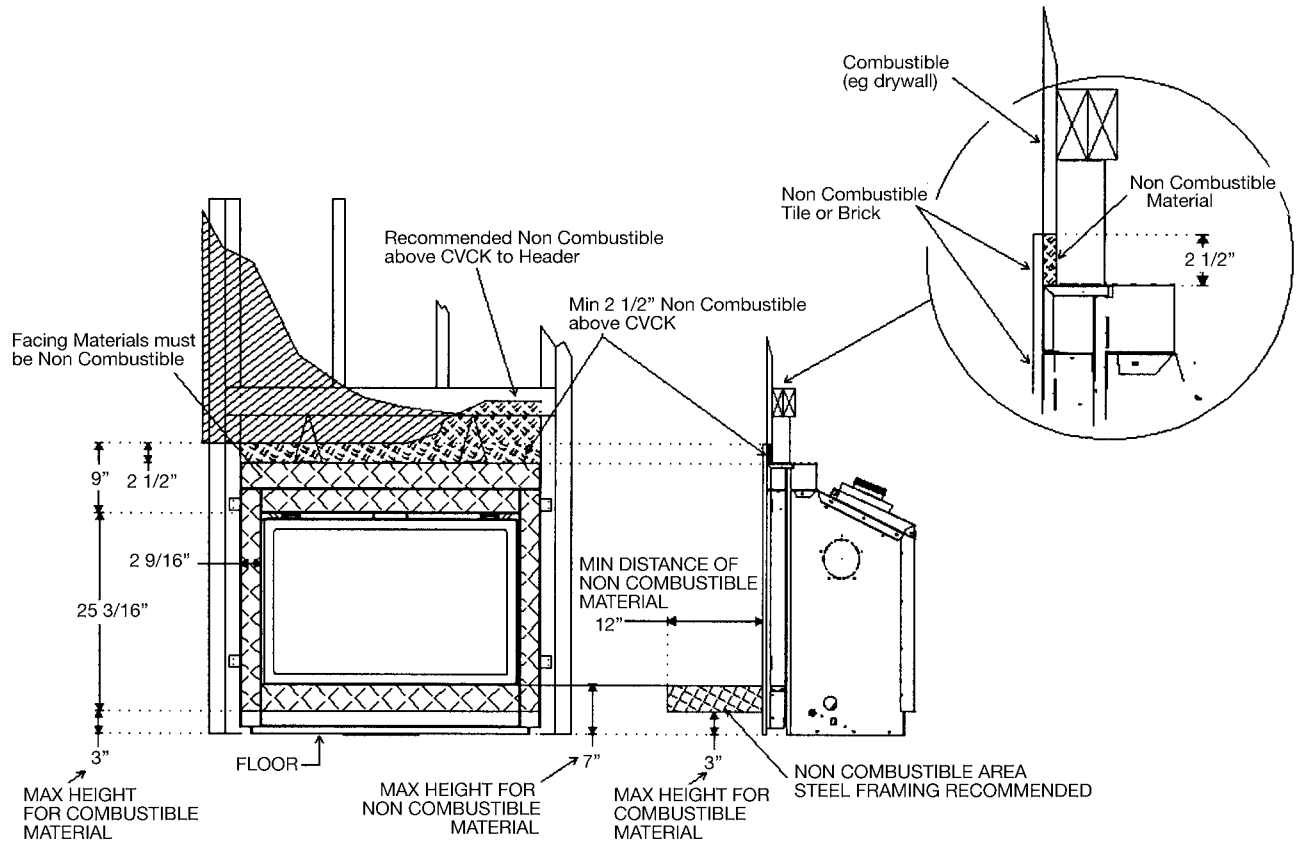

HB36CVCK WITH MQHB36SW SURROUND

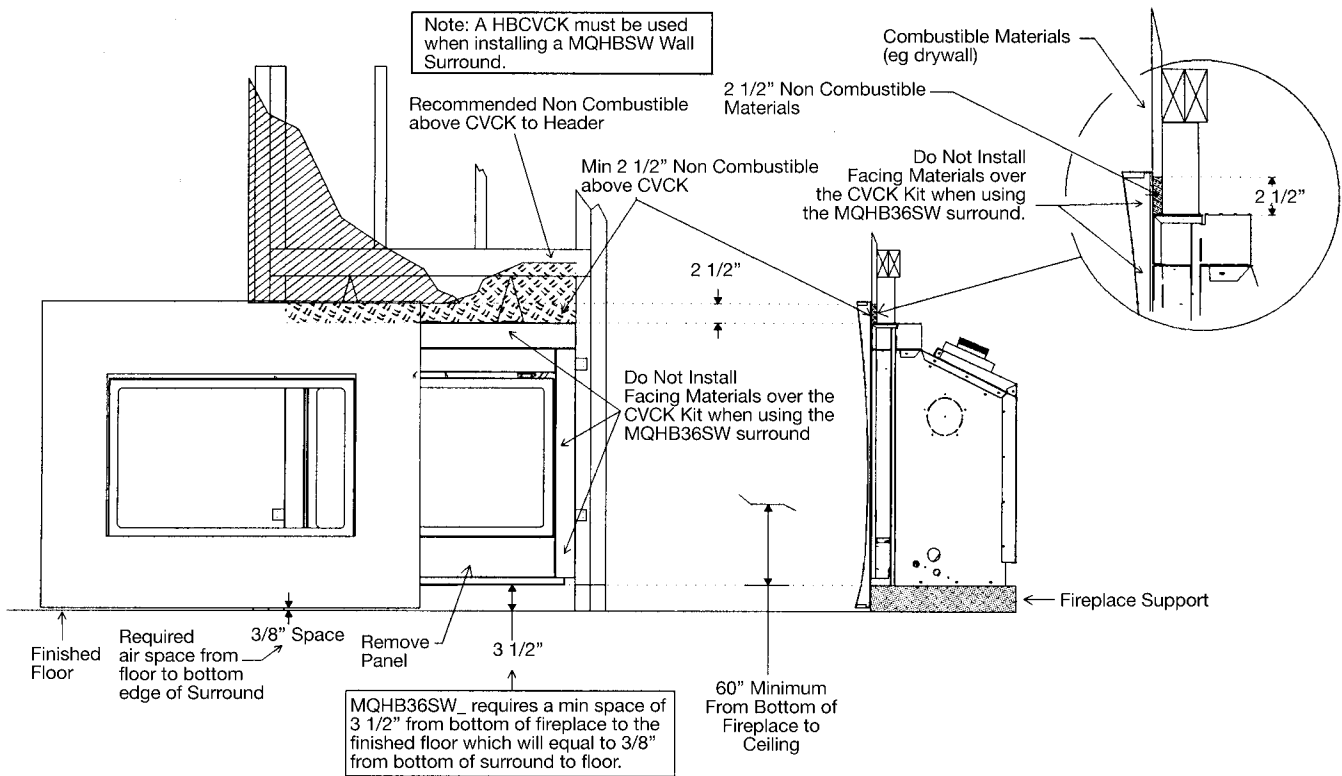

MQHBZDV3636 - HOW TO INSTALL CLEAN VIEW KIT (CVCK)

CAUTION: When using CVCK DO NOT INSTALL a Louver assembly

1. Install optional Fan Kit (See Fan Instruction)
2. Fold two standoffs up into position & mount with supplied Screws. (Fig. 1)
3. Hang CVCK on top of fireplace retainer tabs and rotate down into position. (Fig. 2)
4. Using the screws provided, fasten the non-combustible header onto the top of the CVCK assembly.
5. Using four supplied #6 screws, fasten CVCK kit to the inside frame of unit
6. Kit is supplied with 2 valve extension knobs. Align the notches and slide the extensions onto the valve knobs.
7. DO NOT brick or tile beyond the inside area of the CVCK kit to allow for removal of door.
8. Install optional pull screen system: First slide curtain onto rods and slide round end of rod into side post Ref: A, using 1/2" DT screws, mount the flattened end of rod to the bottom side of the rod hanger bracket (Ref: B). Repeat this step for the opposite side.

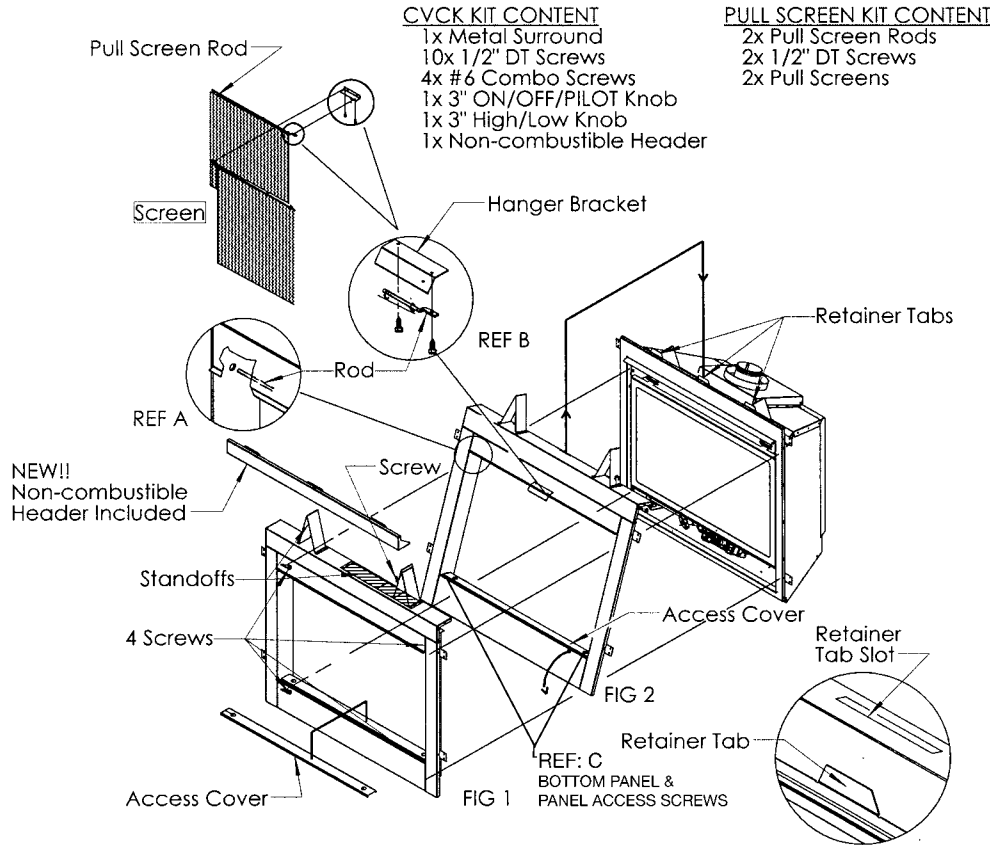

Note: Additional Access for gasoline installation and Fan Electrical installation! When CVCK kit is installed in framing remove 2 screws from the right and left side of bottom panel Ref: C. Once screws are removed, bottom panel can be rotated forward for access to gas valve and fan system.

MQHBZDV3636 - Clearance to Combustibles

Clearance to Combustibles

Back (from Standoffs)	0 inches/0 mm
Side (from standoffs)	0 inches/0 mm
Floor	0 inches/0 mm
Ceiling (from bottom of fireplace)	60 inches/150 cm
Top (from standoffs)	0 inches/0 mm
Top of 90 degree bend in Minimum Enclosure of 42 to 43 inches	3 1/2 inches/140 mm / All Vent Systems
Top of 90 degree bend in Enclosure over 43 inches	2 1/2 inches/38 mm / All Vent Systems
Top of Horizontal Pipe	1 1/2 inches/38 mm / All Vent Systems
Side & Bottom of Horizontal Pipe	1 inch/25.5mm / All Vent Systems
Vertical Vent Pipe	1 inch/25.5mm / Kingsman Vent Systems
Vertical Vent Pipe	1 1/4 inch/32mm / Simpson/AmeriVent/Selkirk Direct Temp Systems

(NOTE -Floor) if installing the appliance directly on carpeting or other combustible materials other than wood flooring, the appliance shall be installed on a metal or wood panel, the full width and depth of the appliance. Carpet may extend 1 inch above the floor of appliance.

For units with CVCK (Clear View Circulating Kit) see framing with CVCK to establish floor heights

MOHBZDV3636 Parts List

Fireplace Part Numbers

MQHBZDV3636N	Fireplace Heater Rated NG, Ceramic Glass, 30,500 BTU AT 75% efficient. Approved for bedroom and mobile home.
MQHBZDV3636LP	Fireplace Heater Rated LP, Ceramic Glass, 29,200 BTU AT 75% efficient. Approved for bedroom and mobile home.

FIREPLACE REQUIREMENTS

Grills or CVCK (clean view circulating kit)(Required for each unit)

HB36CVCK	CVCK(clean view circulating kit) no grill required
HB36GBA	Grill Kit - Classic Builder Antique Brass
HB36GBC	Grill Kit - Classic Builder Chrome
HB36GBP	Grill Kit - Classic Builder Polish Brass
HB36GBL	Grill Kit - Black
HB36PBL	Panel Grill Kit - Black

LOG SETS/ROCK KITS: (Required for each unit)

LOGF36	Log Set - 7 pce. - /Fibre Split Oak
MQRCK1	Rock Set
MQRSP2	Rock Platform, Support, and 4 Screws (MQHBZDV3636, 4236)

Fireplace Wall Mount Finishing Surrounds for HB36CVCK Unit

MQHB36SWCCBL	Surround Concave Black (Coverage 40 1/2" H x 49 1/2" W)
MQHB36SWCCPW	Surround Concave Pewter (Coverage 40 1/2" H x 49 1/2" W)
MQHB36SWCVBL	Surround Convex Black (Coverage 41" H x 40 1/2" W)
MQHB36SWCVPW	Surround Convex Pewter (Coverage 41" H x 40 1/2" W)

ACCESSORIES

Fireplace Surrounds - Trims

HB36SAB	Surround - Antique Brass (Coverage 35 1/2" H x 41 1/8" W)
HB36SBL	Surround - Black (Coverage 35 1/2" H x 41 1/8" W)
HB36SCR	Surround - Chrome (Coverage 35 1/2" H x 41 1/8" W)
HB36SPB	Surround - Polish Brass (Coverage 35 1/2" H x 41 1/8" W)
HB36SLAB	Surround Slim Line - Antique Brass (Coverage 35 1/4" H x 37 1/2" W)
HB36SLCR	Surround Slim Line - Chrome (Coverage 35 1/4" H x 37 1/2" W)
HB36SLPB	Surround Slim Line - Polish Brass (Coverage 35 1/4" H x 37 1/2" W)
HB36SLBL	Surround Slim Line - Gun Metal Black (Coverage 35 1/4" H x 37 1/2" W)

Designer Doors for 36" Fireplaces - Operative

HB36DDA1BL	Designer Door Arch - Series 1 - Black
HB36DDTA1A	Trim - Antique for Designer Arch - Series 1
HB36DDTA1C	Trim - Chrome for Designer Arch - Series 1
HB36DDTA1P	Trim - Polish Brass for Designer Arch - Series 1
HB36DDS1BL	Designer Door Straight - Series 1 - Black
HB36DDTS1A	Trim - Antique for Designer Straight - Series 1
HB36DDTS1C	Trim - Chrome for Designer Straight - Series 1
HB36DDTS1P	Trim - Polish for Designer Straight - Series 1

Child Safety Screens

HB36CSS	Child Safety Screen - 36" HBZDV Fireplaces
HB36PSK	Pull Screen Kit for CVCK

Overlays

HB36ADTH	Arch Door Frame - Top Half Black
HB36ADDX	Arch Door Frame - Deluxe Black
HB36ADDA	Arch Door Frame - Double Arch Black
HB36ADDD	Arch Door Frame - Double Door Arch Black

Accessories

Z36FK	Fan Kit w/Variable Speed Wall Mount Control (Temperature Sensing)
Z1MT	Thermostat Millivolt Wall Mount
Z80PT	Thermostat Programmable Digital Millivolt Wall Mount (1F80-40)
Z1RC	Remote Control Millivolt (On/Off with LED) (Model I)
ZART	Remote Control Thermostat Millivolt (Model K)
RMCBN	Remote Control - Basic - Natural Gas (On/Off, Hi/Lo Flame Adjustment)
RMCBP	Remote Control - Basic - Liquid Propane (On/Off, Hi/Lo Flame Adjustment)
DCHS	Remote Control Heatshield
VLBIT4	Log Bits - Large Four Piece Kit
VLBIT6	Log Bits - Small Six Piece Kit

Refractory Liner

HB36PRL	Porcelain Reflective Liner
HB36RLC	Refractory Liner Classic
HB36RLT	Refractory Liner Traditional
HB36RLH	Refractory Liner Herring Bone

Replacement Burner Assembly

3636MQ-BNGSI	Burner Assembly - Natural Gas c/w Valve System (MQHBZDV3636N)
3636MQ-BLPSI	Burner Assembly - Liquid Propane c/w Valve System (MQHBZDV3636LP)

Conversion Kit (Sit Valve Only)

3632HB-CKLP	LP Conversion Kit for HBZDV3632/3636
3632HB-CKNG	NG Conversion Kit for HBZDV3632/3636

Valve System Parts - New Top convertible SIT

1000-P136WR	Thermopile GOAI-524
1001-P069SI	Electrode Sparker 915.069 TC SIT
1001-P216SI	Thermocouple 290.216 TC SIT
1001-P165SI	Orifice Pilot NG 977.165 TC SIT
1001-P167SI	Orifice Pilot LP 977.167 TC SIT
1001-P633SI	Valve Nova LP Hi/Lo 0820651
1001-P634SI	Valve Nova NG Hi/Lo 0820652
1001-P713SI	Pilot Burner LP 199.713 TC SIT
1001-P714SI	Pilot Burner NG 199.714 TC SIT

Miscellaneous Parts

1000-150GE	#Silicone GE Red IS806 #736
1000-150MP	#Hi-Temp Millpac Sealant 840099
1000-214	#Piezo-Ignitor 1244-17 MARK 21
1000-215	#Pal Nut (18MMX1.5MM)BLK (1364.03)
1000-218	#Switch Ivory (1451/001)
1000-227	#Cover Ivory (86001/001)
1000-255	#Orifice Brass - (State Size)
1000-EMBER	#Moon Rock
2000-080	#Thermodisc 2450 (For Blower)
2000-081	#Blower Motor QLN65/2400
1000-085	#Control Variable Speed KBWC-13BV
1000-306	Thermalcord - Adhesive Back for Door Frame
36HB-310	Ceramic Glass - For All HBZDV3600
36HB-123	Upper Door Spring

Kingsman Fireplace Venting

Catalog

Number	Description
ZDVHSK	Horizontal Vent Starter Kit - 3 FT Length Horizontal Vent Termination, Wall Thimble, 36" Flex Pipe, Mill Pac, screws/washers, springs.
ZDVHSK5	Horizontal Vent Starter Kit - 5 FT Length Horizontal Vent Termination, Wall Thimble, 60" Flex Pipe, Mill Pac, screws/washers, springs.
FDVVT40	Vertical Vent Termination converts from 15'-40' to under 15'
FDVHT	Horizontal Vent Termination
FDVHSQ	Horizontal Square Termination
ZDVST	Horizontal Snorkel Termination (34" Tall, 24" Center to Center)
FDVHSCU	Safety Cage for Horizontal Termination
ZDVAIS	Attic Insulation Shield
ZDVVOS	Offset Support
ZDVFS	Firestop Spacer
ZDVRS	Roof Support
ZDVWT	Wall Thimble (Horizontal Venting)
ZDVSSLR	Siding Shield - Large Return

ZDV48GP	Galvanized Pipe 7" Dia. x 48" (Vertical Installations)
ZDVAAF	Flashing 7" c/w Storm Collar (1/12 to 7/12)
ZDVAF2	Flashing 7" c/w Storm Collar (8/12 to 12/12)
ZDVAF3	Flashing 7" c/w Storm Collar Flat
ZDV7SC	Storm Collar 7"
ZDVFK5	Flex Kit (4" & 7" Dia.) x 2.5' (Unexpanded) 5' Expanded
ZDVFK8	Flex Kit (4" & 7" Dia.) x 4' (Unexpanded) 8' Expanded
ZDVFK20	Flex Kit (4" & 7" Dia.) x 10' (Unexpanded) 20' Expanded *Kits are complete with spring stand-offs, silicone.
ZDV4FC	Flex Connector 4" Diameter
ZDV7FC	Flex Connector 7" Diameter
ZDV4SS	Spring 4" Standoff Spacer
ZDVDFFA	Simpson Dura-Vent Fireplace Adapter (for ZDV33/36/42/47, ZDV6000, MDV30/38 & HB models)
ZDVHKSQ Kit -	Horizontal Square Termination Vent Starter 3 FT Length Horizontal Vent Termination, Wall Thimble, Wall Thimble, 36" Flex Pipe, Mill Pac
ZDVHKSQ5 Kit -	Horizontal Square Termination Vent Starter 5 FT Length Horizontal Vent Termination, Wall Thimble, Wall Thimble, 60" Flex Pipe, Mill Pac
FDVHSQ	Horizontal Square Vent Termination

MQHBZDV4236 - Locating your Appliance

Installing with Top Vent

- A - Flat on a wall
- B - Across the corner
- C - As an island
- D - As a room divider
- E - Flat on wall corner
- F - Exterior wall

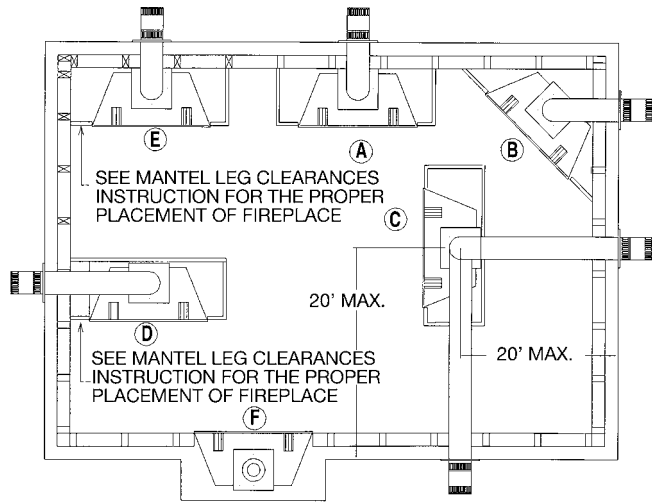

Island installation with a top vent is possible as long as the horizontal portion of the vent system does not exceed 20 feet (6.1 m).

Fireplace Dimensions

MQHBZDV42 Louvered

MQHBZDV42 -CVCK (Clean View Circulating Kit)

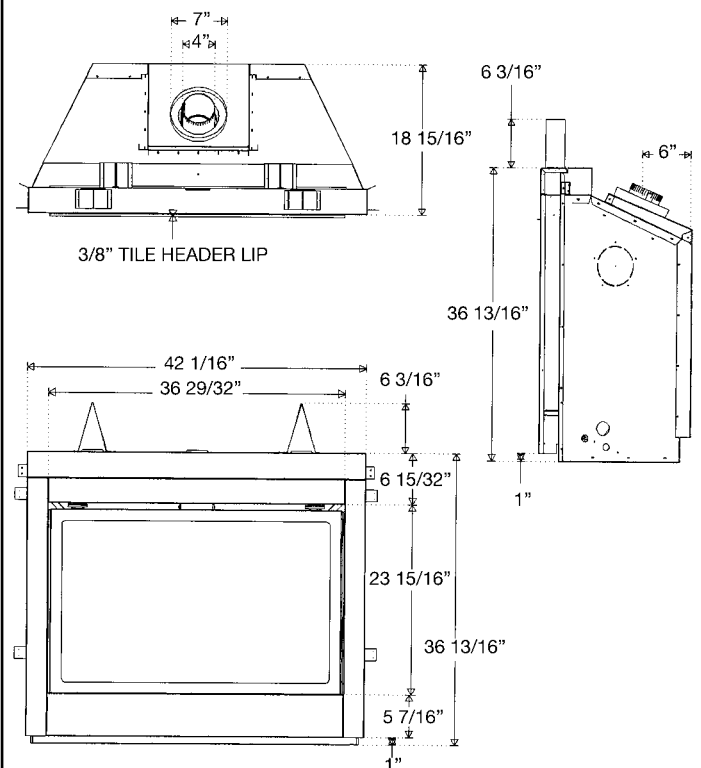
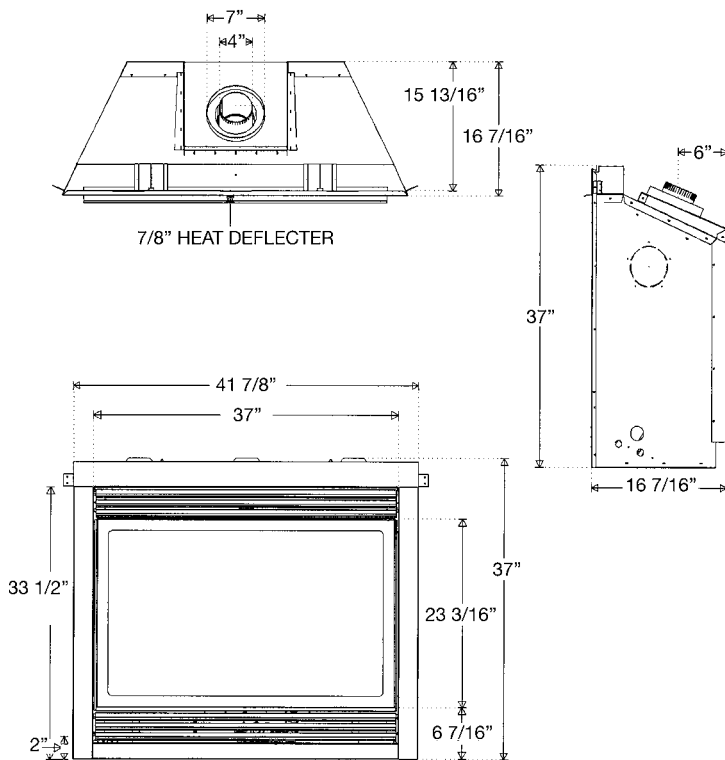

MQHBZDV4236 - Framing for your Gas Fireplace

Framing Specifications

1. Cold climate installation recommendation: When installing this fireplace against non insulated exterior wall or chase, it is recommended that the outer walls be insulated to conform to applicable insulation codes. Drywall must be installed over insulation to prevent contact of insulation and unit.
2. Choose fireplace location and frame in accordance with the fireplace framing dimensions specified (See Framing Diagrams). Bend nailing tabs forward on left and right of unit and place fireplace into framed enclosure. This allows for 1/2" in front of framing tabs for finishing materials.
3. Drywall or other material can extend flush with the appliance on the bottom, sides and top of fireplace. (louvered models only)
4. When installing horizontal with a 90 degree bend maintain a minimum of two and a half (2.5") inches above the bend in enclosures.
5. For a fireplace with louvers combustible floor can raise 1" above the bottom of the fireplace. For a fireplace with HB42CVCK (Clean view Circulating Kit) floor or hearth can raise 7" above the bottom of the fireplace with portions being combustible and non combustible. See drawing on following page.
6. When installing MQHB42SW surround, the fireplace must be raised a minimum of 3 1/2" above the finished floors, to accommodate the wall surround. The fireplace may be raised higher but the 60" clearance measured from the bottom of the fireplace to the ceiling must be maintained at all times. (i.e. For an 8 ft. ceiling the unit can be raised only 36 inches.)

It is recommended for **Propane Horizontal Installations** that the venting should be a minimum of one foot vertical off the flue before the elbow on any horizontal runs of one foot or greater. This allows for cleaner combustion and greatly reduces carboning and cleaning of glass. (Does not apply to Back Flue Models).

MQHBZDV42 louvered

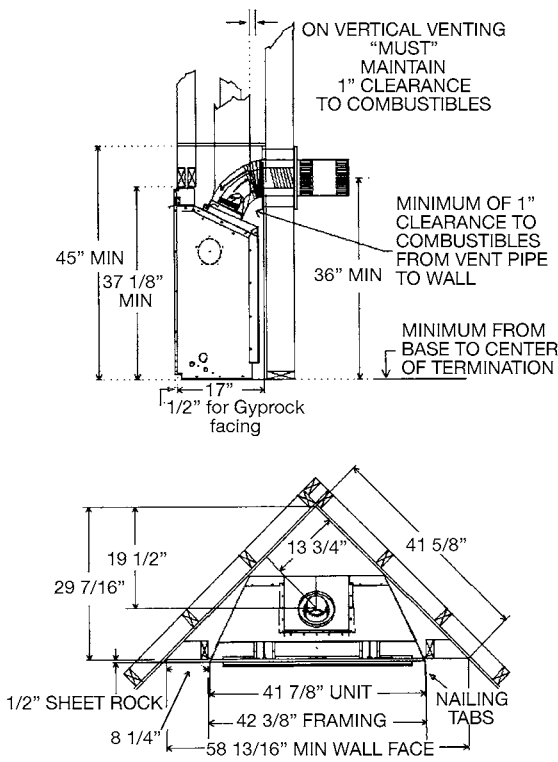

MQHBZDV42 WITH CVCK (CLEAN VIEW CIRCULATING KIT)

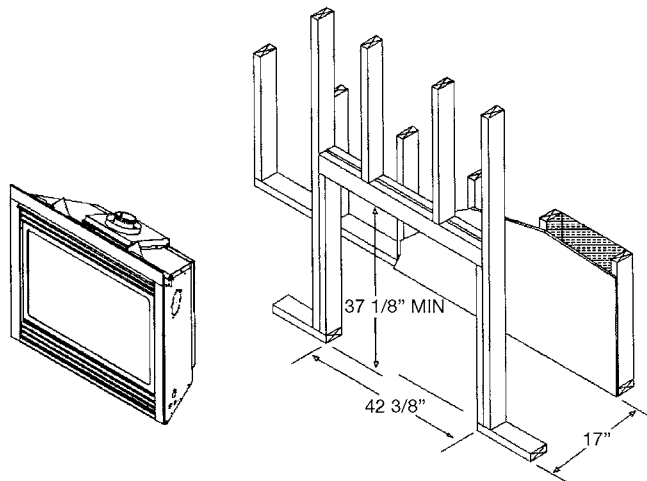
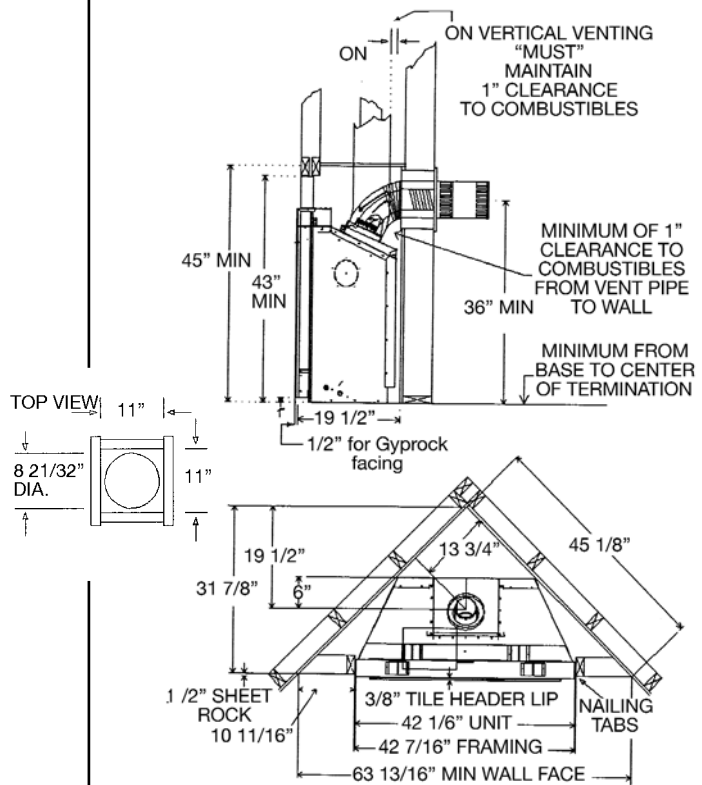

NOTE: When adding a MQHB42SW wall surround, the fireplace must be raised a minimum of 3 1/2" above the finished floor to accommodate the wall surround. (See next page)

MQHBZDV4236 - Framing and Facing Requirements

HBZDV42 WITH HB42CVCK (CLEAN VIEW CIRCULATING KIT)

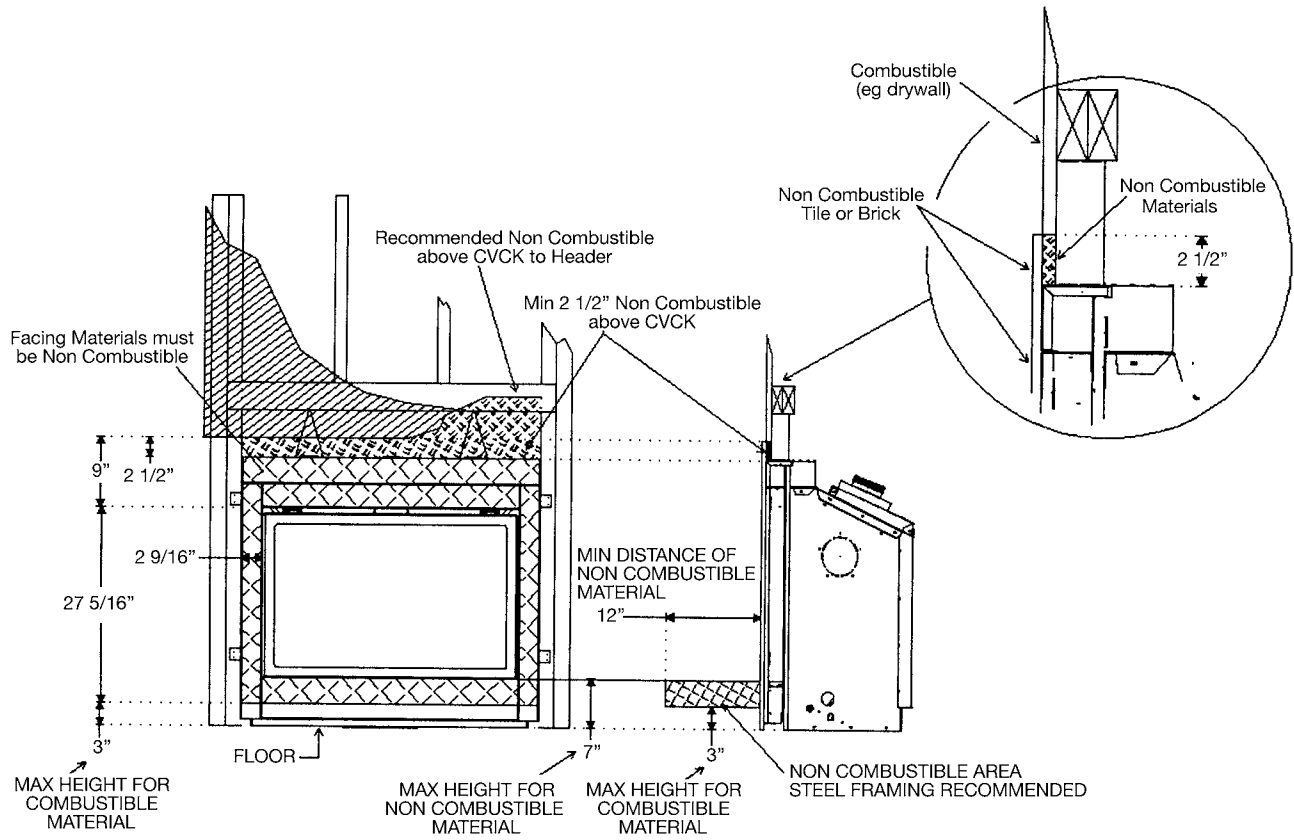

HB42CVCK WITH MQHB42SW SURROUND

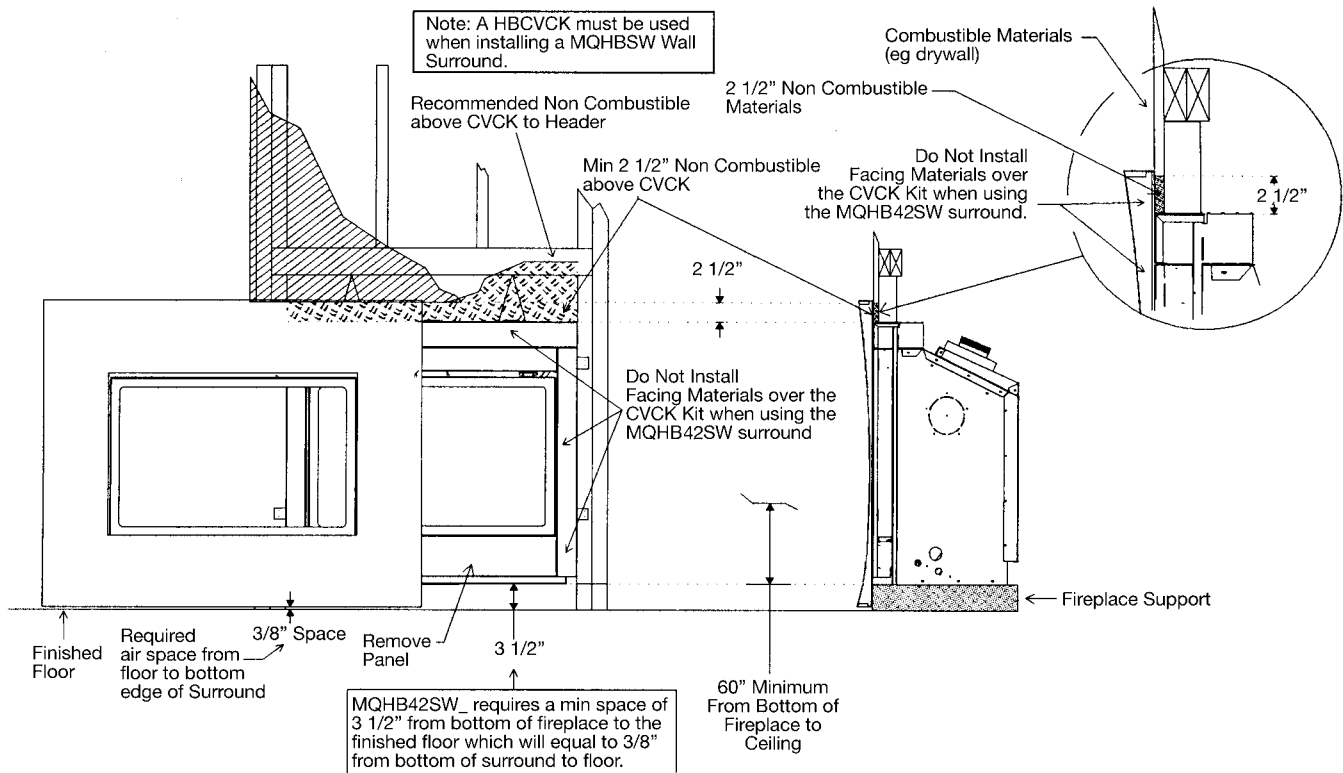

MOHBZDV 4236 - HOW TO INSTALL CLEAN VIEW KIT (CVCK)

CAUTION: When using CVCK DO NOT INSTALL a Louver assembly

1. Install optional Fan Kit (See Fan Instruction)
2. Fold two standoffs up into position & mount with supplied Screws. (Fig. 1)
3. Hang CVCK on top of fireplace retainer tabs and rotate down into position. (Fig. 2)
4. Using the screws provided, fasten the non-combustible header onto the top of the CVCK assembly.
5. Using four supplied #6 screws, fasten CVCK kit to the inside frame of unit
6. Kit is supplied with 2 valve extension knobs. Align the notches and slide the extensions onto the valve knobs.
7. DO NOT brick or tile beyond the inside area of the CVCK kit to allow for removal of door.
8. Install optional pull screen system: First slide curtain onto rods and slide round end of rod into side post Ref: A, using 1/2" DT screws, mount the flattened end of rod to the bottom side of the rod hanger bracket (Ref: B). Repeat this step for the opposite side.

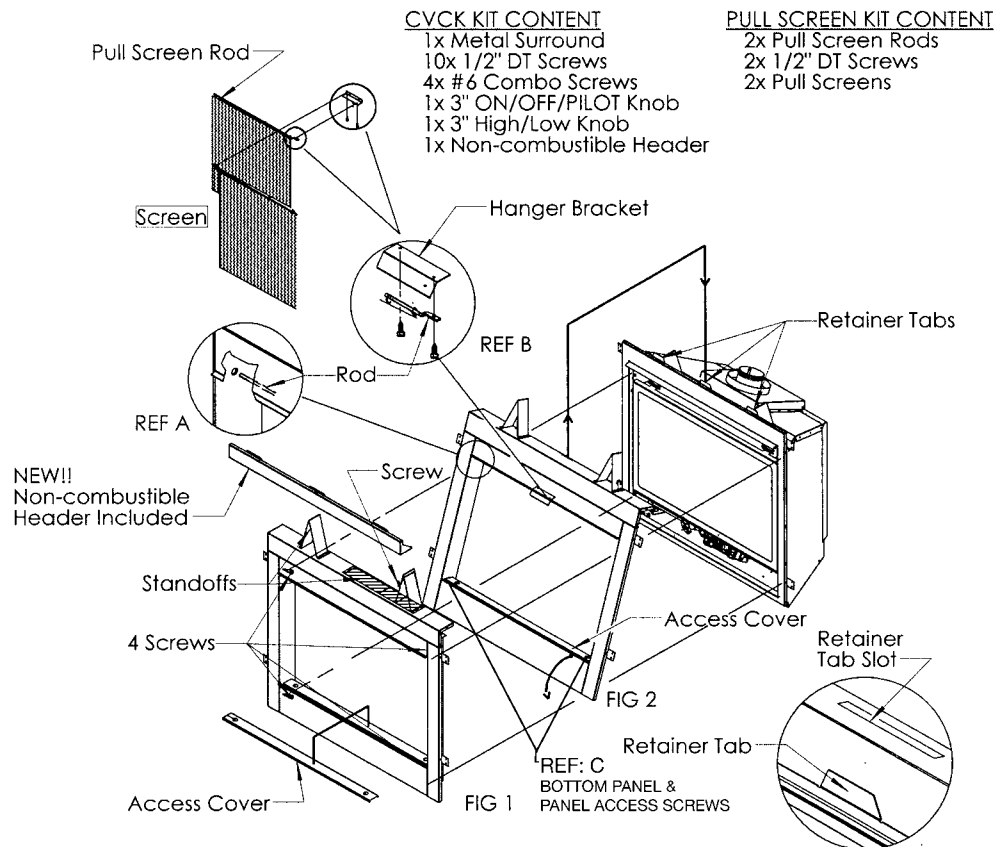

Note: Additional Access for gasline installation and Fan Electrical installation! When CVCK kit is installed in framing remove 2 screws from the right and left side of bottom panel Ref: C. Once screws are removed, bottom panel can be rotated forward for access to gas valve and fan system.

MOHBZDV 4236 - Clearance to Combustibles

Clearance to Combustibles

Back (from Standoffs)	0 inches/0 mm
Side (from standoffs)	0 inches/0 mm
Floor	0 inches/0 mm
Ceiling (from bottom of fireplace)	60 inches/150 cm
Top (from standoffs)	0 inches/0 mm
Top of 90 degree bend in Minimum Enclosure of 45 to 46 inches	5 inches/128 mm / All Vent Systems
Top of 90 degree bend in Enclosure over 46 inches	2 1/2 inches/64 mm / All Vent Systems
Top of Horizontal Pipe	1 1/2 inches/38 mm / All Vent Systems
Side & Bottom of Horizontal Pipe	1 inch/25.5mm / All Vent Systems
Vertical Vent Pipe	1 inch/25.5mm / Kingsman Vent Systems
Vertical Vent Pipe	1 1/4 inch/32mm / Simpson/AmeriVent/Selkirk Direct Temp Systems

(NOTE -Floor) if installing the appliance directly on carpeting or other combustible materials other than wood flooring, the appliance shall be installed on a metal or wood panel, the full width and depth of the appliance. Carpet may extend 1 inch above the floor of appliance.

For units with CVCK (Clear View Circulating Kit) see framing with CVCK to establish floor heights

MQHBZDV4236 - Parts List

Fireplace Part Numbers

MQHBZDV4236N	Fireplace Heater Rated NG, Ceramic Glass, 30,500 BTU AT 75% efficient. Approved for bedroom and mobile home.
MQHBZDV4236LP	Fireplace Heater Rated LP, Ceramic Glass, 29,200 BTU AT 75% efficient. Approved for bedroom and mobile home.

FIREPLACE REQUIREMENTS

Grills or CVCK (clean view circulating kit)(Required for each unit)

HB42CVCK	CVCK(clean view circulating kit) no grill required
HB42GBA	Grill Kit - Classic Builder Antique Brass
HB42GBC	Grill Kit - Classic Builder Chrome
HB42GBP	Grill Kit - Classic Builder Polish Brass
HB42GBL	Grill Kit - Black
HB42PBL	Panel Grill Kit - Black

LOG SETS/ROCK KITS: (Required for each unit)

LOGF36	Log Set - 7 pce. - Fibre Split
MQROCK1	Rock Set
MQRSP2	Rock Platform, Support and 4 Screws (MQHBZDV3636, MQHBZDV4236)

Fireplace Wall Mount Finishing Surround for HB42CVCK Kits

MQHB42SWCCBL	Surround Concave Black (Coverage 42 3/4" H x 55 7/16" W)
MQHB42SWCCPW	Surround Concave Pewter (Coverage 42 3/4" H x 55 7/16" W)
MQHB42SWCVBL	Surround Convex Black (Coverage 42 15/16" H x 44 5/16" W)
MQHB42SWCVPW	Surround Convex Pewter (Coverage 42 15/16" H x 44 5/16" W)

ACCESSORIES

Fireplace Surrounds - Trims

HB42SAB	Surround - Antique Brass (Coverage 37 5/8" H x 45 1/8" W)
HB42SBL	Surround - Black (Coverage 37 5/8" H x 45 1/8" W)
HB42SCR	Surround - Chrome (Coverage 37 5/8" H x 45 1/8" W)
HB42SPB	Surround - Polish Brass (Coverage 37 5/8" H x 45 1/8" W)
HB42SLAB	Surround Slim Line - Antique Brass (Coverage 37 3/8" H x 43 3/8" W)
HB42SLCR	Surround Slim Line - Chrome (Coverage 37 3/8" H x 43 3/8" W)
HB42SLPB	Surround Slim Line - Polish Brass (Coverage 37 3/8" H x 43 3/8" W)
HB42SLBL	Surround Slim Line - Gun Metal Black (Coverage 37 3/8" H x 43 3/8" W)

Designer Doors for 42" Fireplaces - Operative

HB42DDA1BL	Designer Door Arch - Series 1 - Black
HB42DDTA1A	Trim - Antique for Designer Arch - Series 1
HB42DDTA1C	Trim - Chrome for Designer Arch - Series 1
HB42DDTA1P	Trim - Polish Brass for Designer Arch - Series 1
HB42DDS1BL	Designer Door Straight - Series 1 - Black
HB42DDTS1A	Trim - Antique for Designer Straight - Series 1
HB42DDTS1C	Trim - Chrome for Designer Straight - Series 1
HB42DDTS1P	Trim - Polish for Designer Straight - Series 1

Child Safety Screens

HB42CSS	Child Safety Screen - 42" HBZDV Fireplaces
HB42PSK	Pull Screen Kit for CVCK

Overlays

HB42ADTH	Arch Door Frame - Top Half Black
HB42ADDX	Arch Door Frame - Deluxe Black
HB42ADDA	Arch Door Frame - Double Arch Black
HB42ADDD	Arch Door Frame - Double Door Arch Black

Accessories

Z36FK	Fan Kit w/Variable Speed Wall Mount Control (Temperature Sensing)
Z1MT	Thermostat Millivolt Wall Mount
Z80PT	Thermostat Programmable Digital Millivolt Wall Mount (1F80-40)
Z1RC	Remote Control Millivolt (On/Off with LED) (Model I)
ZART	Remote Control Thermostat Millivolt (Model K)
RMCBN	Remote Control - Basic - Natural Gas (On/Off, Hi/Lo Flame Adjustment)
RMCBP	Remote Control - Basic - Liquid Propane (On/Off, Hi/Lo Flame Adjustment)
DCHS	Remote Control Heatshield
VLBIT4	Log Bits - Large Four Piece Kit
VLBIT6	Log Bits - Small Six Piece Kit

Refractory Liner

HB42PRL	Porcelain Reflective Liner
HB42RLC	Refractory Liner Classic
HB42RLT	Refractory Liner Traditional
HB42RLH	Refractory Liner Herring Bone

Replacement Burner Assembly

4236MQ-BNGSI	Burner Assembly - Natural Gas c/w Valve System (MQHBZDV4236N)
4236MQ-BLPSI	Burner Assembly - Liquid Propane c/w Valve System (MQHBZDV4236LP)

Conversion Kit (Sit Valve Only)

4232HB-CKLP	LP Conversion Kit for HBZDV4232/4236
4232HB-CKNG	NG Conversion Kit for HBZDV4232/4236

Valve System Parts - New Top convertible SIT

1000-P136WR	Thermopile GOAI-524
1001-P069SI	Electrode Sparker 915.069 TC SIT
1001-P216SI	Thermocouple 290.216 TC SIT
1001-P165SI	Orifice Pilot NG 977.165 TC SIT
1001-P167SI	Orifice Pilot LP 977.167 TC SIT
1001-P633SI	Valve Nova LP Hi/Lo 0820651
1001-P634SI	Valve Nova NG Hi/Lo 0820652
1001-P713SI	Pilot Burner LP 199.713 TC SIT
1001-P714SI	Pilot Burner NG 199.714 TC SIT

Miscellaneous Parts

1000-150GE	#Silicone GE Red IS806 #736
1000-150MP	#Hi-Temp Mill Pac Sealant 840099
1000-214	#Piezo-Ignitor 1244-17 MARK 21
1000-215	#Pal Nut (18MMX1.5MM)BLK (1364.03)
1000-218	#Switch Ivory (1451/001)
1000-227	#Cover Ivory (86001/001)
1000-255	#Orifice Brass - (State Size)
1000-EMBER	#Moon Rock
2000-080	#Thermodisc 2450 (For Blower)
2000-081	#Blower Motor QLN65/2400
1000-085	#Control Variable Speed KBWC-13BV
1000-306	Thermalcord - Adhesive Back for Door Frame
42HB-310	Ceramic Glass - For All HBZDV4200
36HB-123	Upper Door Spring

Kingsman Fireplace Venting

Catalog

Number	Description
ZDVHSK	Horizontal Vent Starter Kit - 3 FT Length Horizontal Vent Termination, Wall Thimble, 36" Flex Pipe, Mill Pac, screws/washers, springs.
ZDVHSK5	Horizontal Vent Starter Kit - 5 FT Length Horizontal Vent Termination, Wall Thimble, 60" Flex Pipe, Mill Pac, screws/washers, springs.
FDVVT40	Vertical Vent Termination converts from 15'-40' to 15' and under
FDVHT	Horizontal Vent Termination
FDVHSQ	Horizontal Square Termination
ZDVST	Horizontal Snorkel Termination (34" Tall, 24" Center to Center)
FDVHSC	Safety Cage for Horizontal Termination
ZDVAIS	Attic Insulation Shield
ZDVVOS	Offset Support
ZDVFS	Firestop Spacer
ZDVRS	Roof Support
ZDVWT	Wall Thimble (Horizontal Venting)
ZDVSSLR	Siding Shield - Large Return

ZDV48GP	Galvanized Pipe 7" Dia. x 48" (Vertical Installations)
ZDVAAF	Flashing 7" c/w Storm Collar (1/12 to 7/12)
ZDVAF2	Flashing 7" c/w Storm Collar (8/12 to 12/12)
ZDVAF3	Flashing 7" c/w Storm Collar Flat
ZDV7SC	Storm Collar 7"
ZDVFK5	Flex Kit (4" & 7" Dia.) x 2.5' (Unexpanded) 5' Expanded
ZDVFK8	Flex Kit (4" & 7" Dia.) x 4' (Unexpanded) 8' Expanded
ZDVFK20	Flex Kit (4" & 7" Dia.) x 10' (Unexpanded) 20' Expanded *Kits are complete with spring stand-offs, silicone.
ZDV4FC	Flex Connector 4" Diameter
ZDV7FC	Flex Connector 7" Diameter
ZDV4SS	Spring 4" Standoff Spacer
ZDVDFEA	Simpson Dura-Vent Fireplace Adapter (for ZDV33/36/42/47, ZDV6000, MDV30/38 & HB models)
ZDVHKSQ	Horizontal Square Termination Vent Starter Kit - 3 FT Length Horizontal Vent Termination, Wall Thimble, Wall Thimble, 36" Flex Pipe, Mill Pac
ZDVHKSQ5	Horizontal Square Termination Vent Starter Kit - 5 FT Length Horizontal Vent Termination, Wall Thimble, Wall Thimble, 60" Flex Pipe, Mill Pac
FDVHSQ	Horizontal Square Vent Termination

MQHBZDV4736 - Locating your Appliance

Installing with Top Vent

- A - Flat on a wall
- B - Across the corner
- C - As an island
- D - As a room divider
- E - Flat on wall corner
- F - Exterior wall

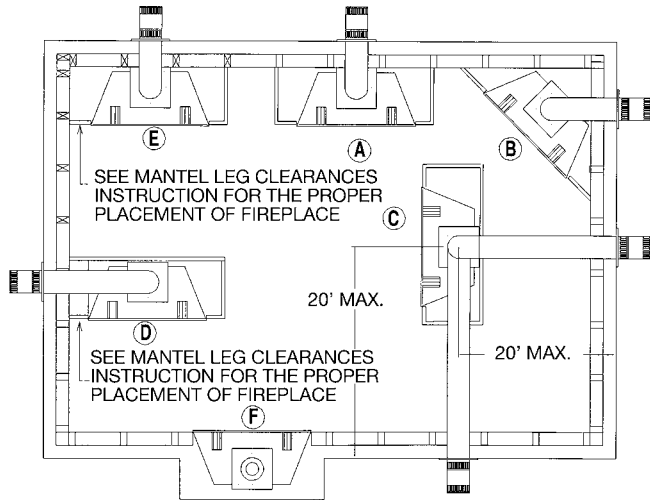

Island installation with a top vent is possible as long as the horizontal portion of the vent system does not exceed 20 feet (6.1 m).

Fireplace Dimensions

MQHBZDV47 Louvered

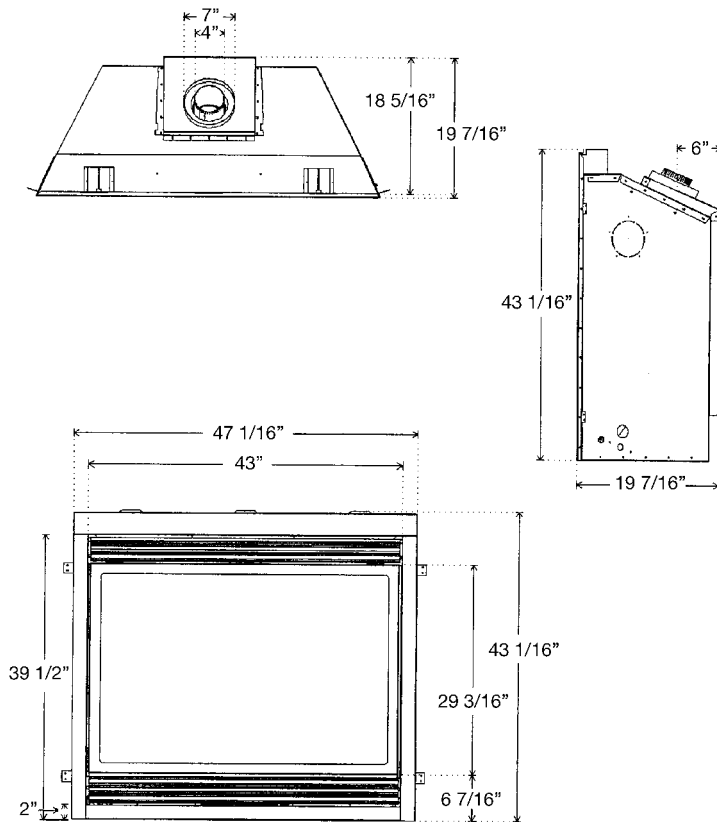

MQHBZDV47 -CVCK (Clean View Circulating Kit)

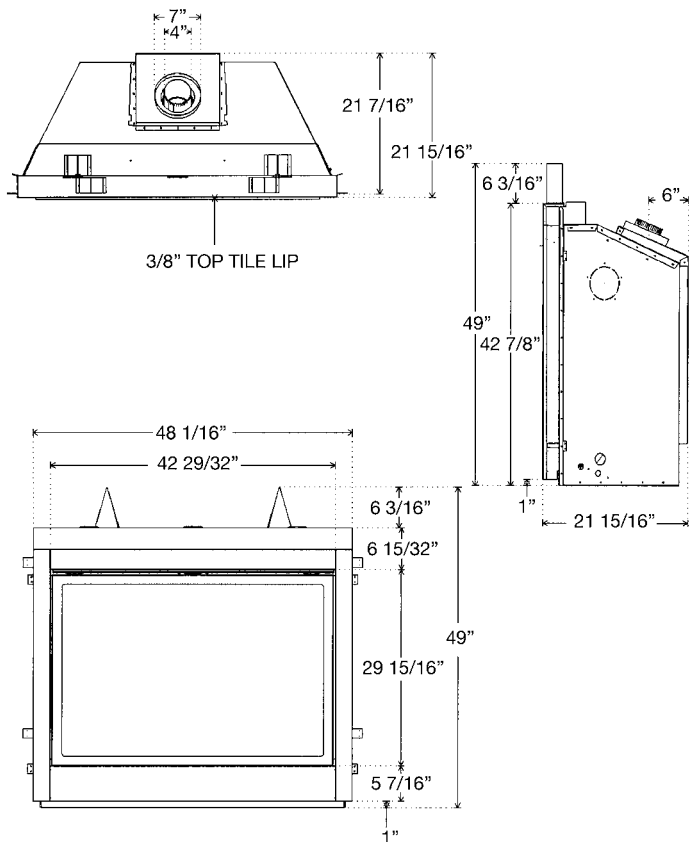

MQHBZDV4736 - Framing for your Gas Fireplace

Framing Specifications

1. Cold climate installation recommendation: When installing this fireplace against non insulated exterior wall or chase, it is recommended that the outer walls be insulated to conform to applicable insulation codes. Drywall must be installed over insulation to prevent contact of insulation and unit.
2. Choose fireplace location and frame in accordance with the fireplace framing dimensions specified (See Framing Diagrams). Bend nailing tabs forward on left and right of unit and place fireplace into framed enclosure. This allows for 1/2" in front of framing tabs for finishing materials.
3. Drywall or other material can extend flush with the appliance on the bottom, sides and top of fireplace. (louvered models only)
4. When installing horizontal with a 90 degree bend maintain a minimum of two and a half (2.5") inches above the bend in

- enclosures, insulation sleeve is required. If greater than six and a half (6.5") an insulation sleeve is not required.
5. For a fireplace with louvers combustible floor can raise 1" above the bottom of the fireplace. For a fireplace with HB47CVCK (Clean view Circulating Kit) floor or hearth can raise 7" above the bottom of the fireplace with portions being combustible and non combustible. See drawing on following page.
6. When installing MQHB47SWCC wall surround, the fireplace must be raised a minimum of 3 1/2" above the finished floor, to accommodate the wall surround. When installing MQHB47SWCV wall surround the fireplace must be raised 2 3/4" above the finished floor. The fireplace may be raised higher but the 60" clearance measured from the bottom of the fireplace to the ceiling must be maintained at all times. (i.e. For an 8 ft. ceiling the unit can be raised only 36 inches.)

It is recommended for **Propane Horizontal Installations** that the venting should be a minimum of one foot vertical off the flue before the elbow on any horizontal runs of one foot or greater. This allows for cleaner combustion and greatly reduces carboning and cleaning of glass. (Does not apply to Back Flue Models).

MQHBZDV47 Louvered

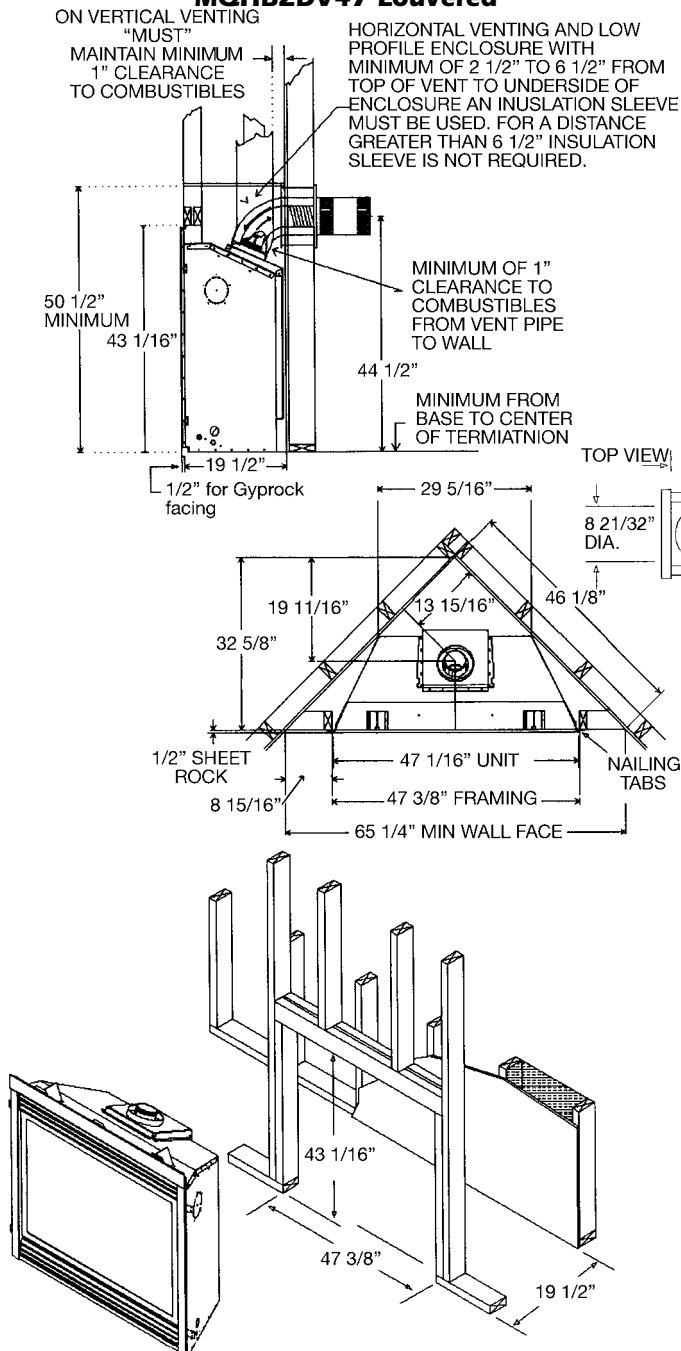

MQHBZDV47 WITH CVCK (CLEAN VIEW CIRCULATING KIT)

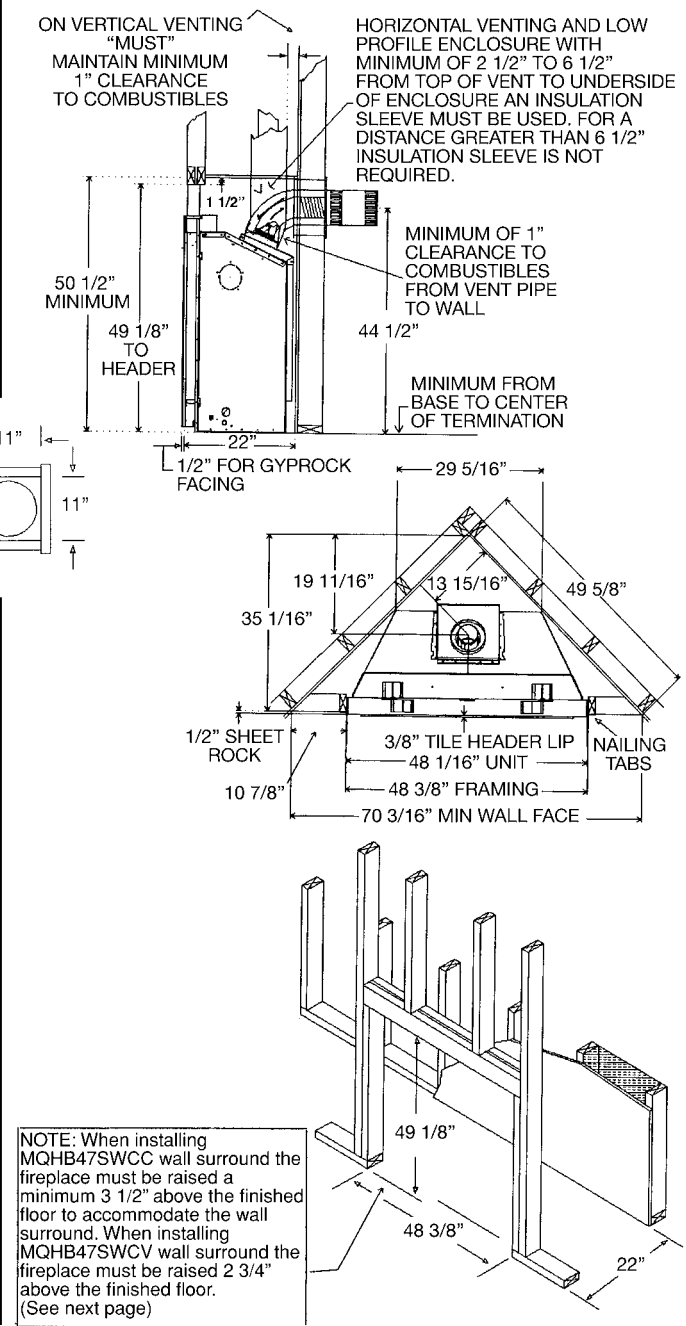

NOTE: When installing MQHB47SWCC wall surround the fireplace must be raised a minimum 3 1/2" above the finished floor to accommodate the wall surround. When installing MQHB47SWCV wall surround the fireplace must be raised 2 3/4" above the finished floor. (See next page)

MQHBZDV4736 - Framing and Facing Requirements

HBZDV47 WITH HB47CVCK (CLEAN VIEW CIRCULATING KIT)

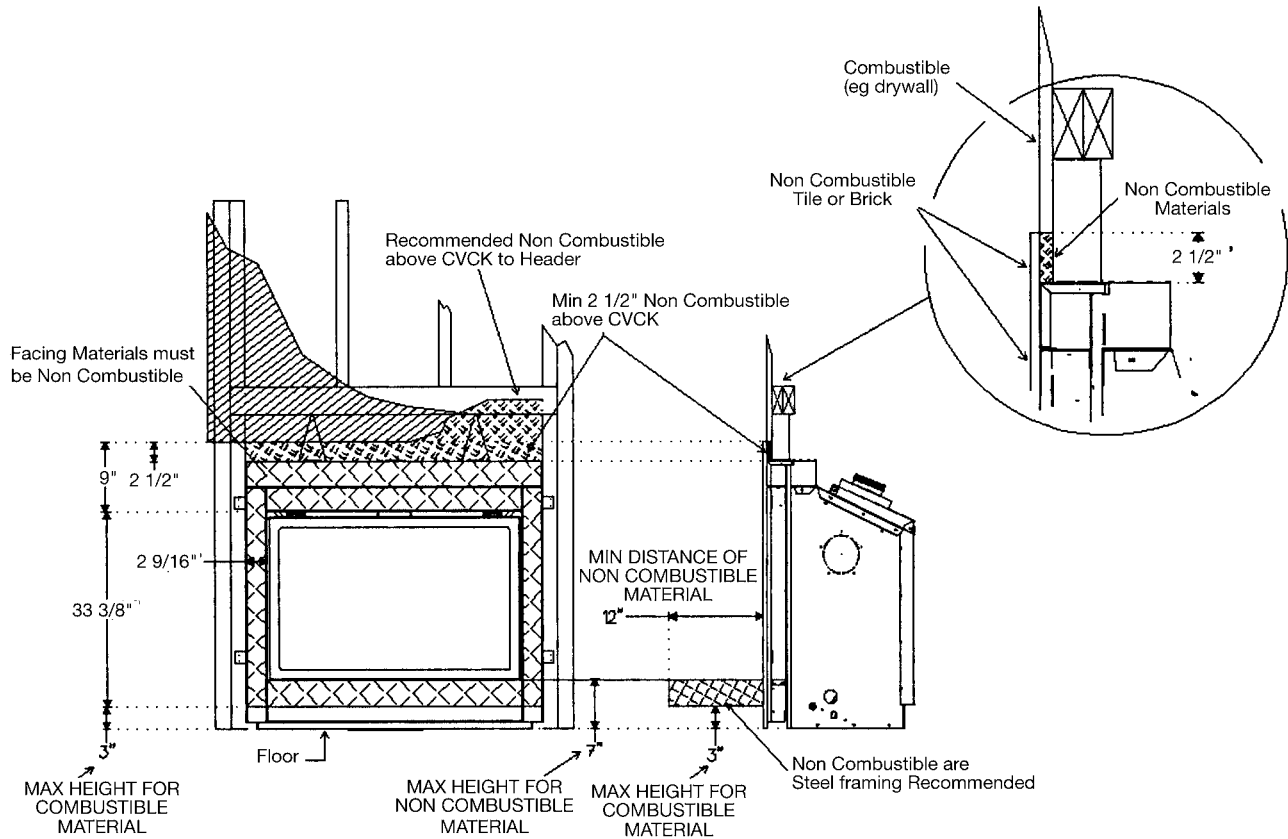

HB47CVCK WITH MQHB47SW SURROUND

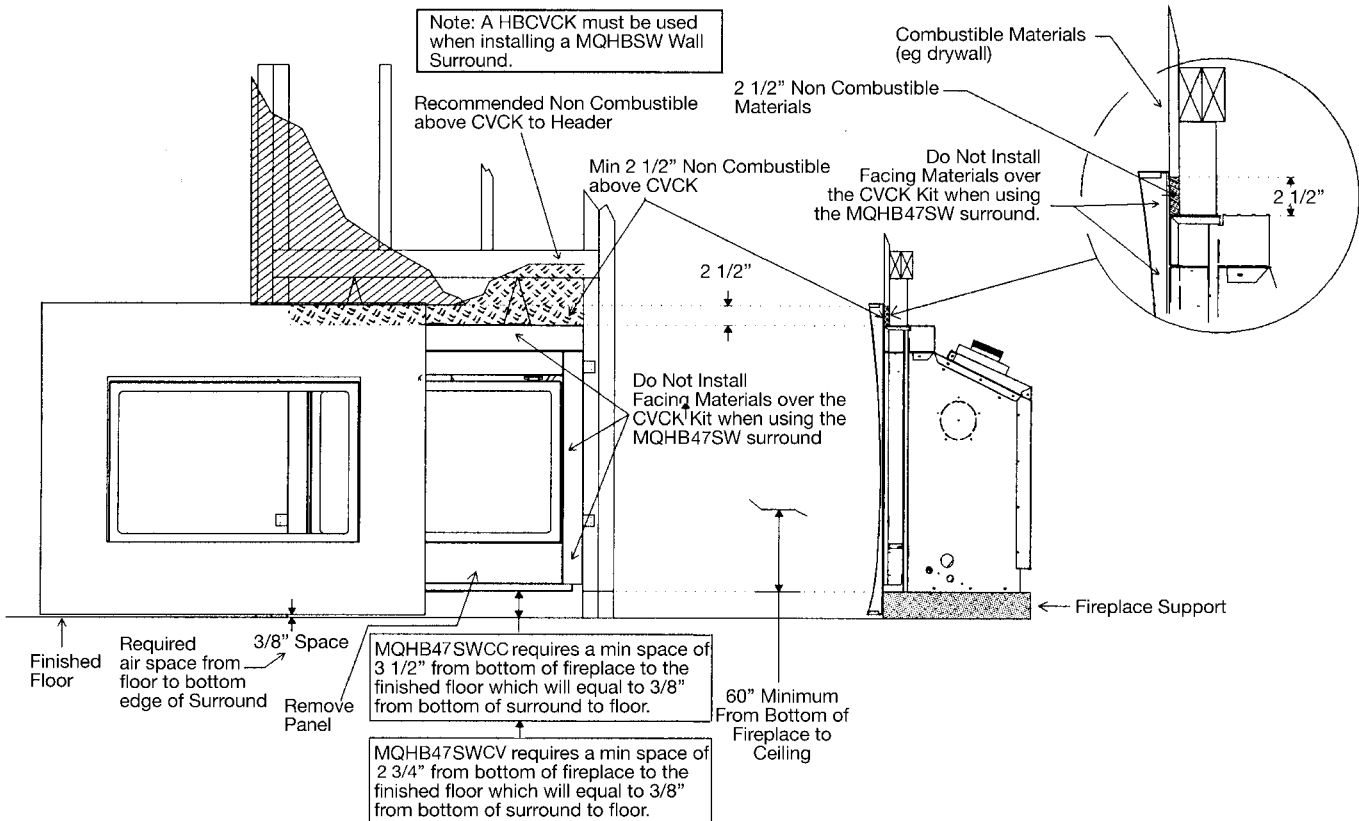

MQHBZDV4736 - HOW TO INSTALL CLEAN VIEW KIT (CVCK)

CAUTION: When using CVCK DO NOT INSTALL a Louver assembly

1. Install optional Fan Kit (See Fan Instruction)
2. Fold two standoffs up into position & mount with supplied Screws. (Fig. 1)
3. Hang CVCK on top of fireplace retainer tabs and rotate down into position. (Fig. 2)
4. Using the screws provided, fasten the non-combustible header onto the top of the CVCK assembly.
5. Using four supplied #6 screws, fasten CVCK kit to the inside frame of unit
6. Kit is supplied with 2 valve extension knobs. Align the notches and slide the extensions onto the valve knobs.
7. DO NOT brick or tile beyond the inside area of the CVCK kit to allow for removal of door.
8. Install optional pull screen system: First slide curtain onto rods and slide round end of rod into side post Ref: A, using 1/2" DT screws, mount the flattened end of rod to the bottom side of the rod hanger bracket (Ref: B). Repeat this step for the opposite side.

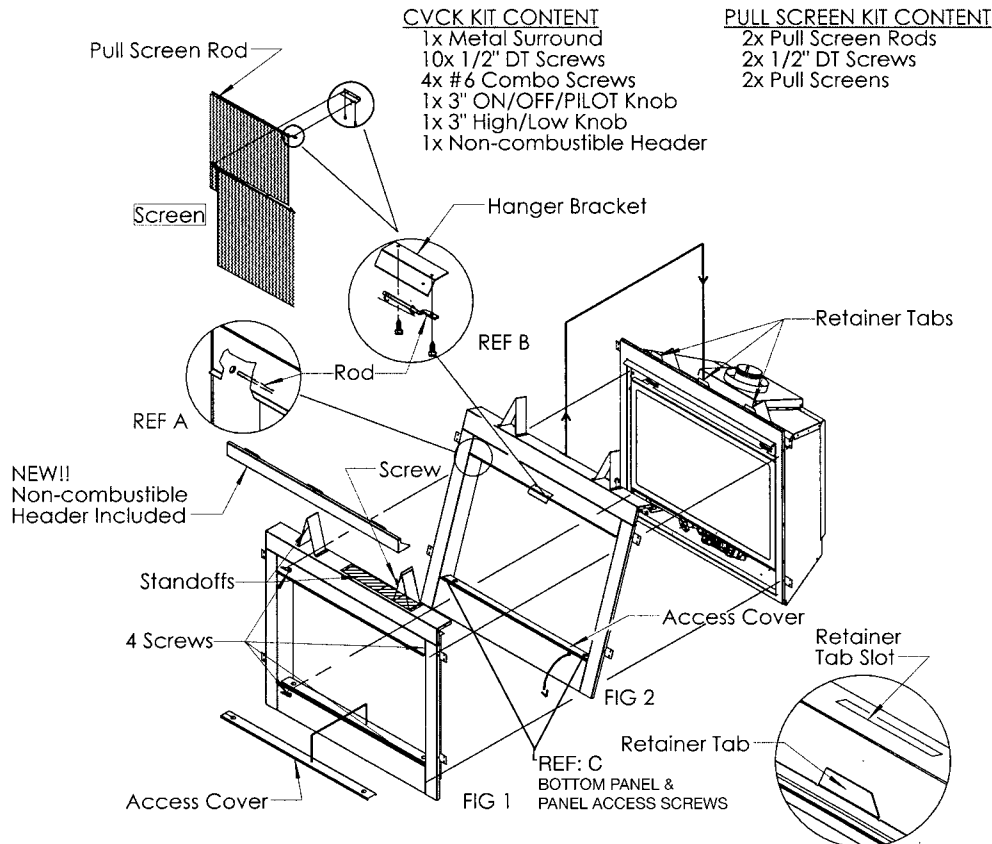

Note: Additional Access for gasline installation and Fan Electrical installation! When CVCK kit is installed in framing remove 2 screws from the right and left side of bottom panel Ref: C. Once screws are removed, bottom panel can be rotated forward for access to gas valve and fan system.

MQHBZDV4736 - Clearance to Combustibles

Clearance to Combustibles

Back (from Standoffs)	0 inches/0 mm
Side (from standoffs)	0 inches/0 mm
Floor	0 inches/0 mm
Ceiling (from bottom of fireplace)	60 inches/150 cm
Top (from standoffs)	0 inches/0 mm
Top of 90 degree bend in Minimum Enclosure of 50 1/2 to 56 1/2 inches	with insulation sleeve 2 1/2 inches/64 mm / All Vent Systems
Top of 90 degree bend in Enclosure over 56 1/2 to 60 inches	without insulation sleeve 4 1/2 inches/114.75 mm / All Vent Systems
Top of 90 degree bend in Enclosure over 60 inches	without insulation sleeve 2 1/2 inches/64 mm / All Vent Systems
Side & Bottom of Horizontal Pipe	1 inch/25.5mm / All Vent Systems
Vertical Vent Pipe	1 inch/25.5mm / Kingsman Vent Systems
Vertical Vent Pipe	1 1/4 inch/32mm / Simpson/AmeriVent/Selkirk Direct Temp Systems

(NOTE -Floor) if installing the appliance directly on carpeting or other combustible materials other than wood flooring, the appliance shall be installed on a metal or wood panel, the full width and depth of the appliance. Carpet may extend 1 inch above the floor of appliance.

For units with CVCK (Clear View Circulating Kit) see framing with CVCK to establish floor heights

MQHBZDV4736 - Parts List

Fireplace Part Numbers

MQHBZDV4736N	Fireplace Decorative Rated NG, Tempered Glass, 40,000 BTU
MQHBZDV4736LP	Fireplace Decorative Rated LP, Tempered Glass, 40,000 BTU

FIREPLACE REQUIREMENTS

Grills or CVCK (clean view circulating kit)(Required for each unit)

HB47CVCK	CVCK(clean view circulating kit) no grill required
HB47GBA	Grill Kit - Classic Builder Antique Brass
HB47GBC	Grill Kit - Classic Builder Chrome
HB47GBP	Grill Kit - Classic Builder Polish Brass
HB47GBL	Grill Kit - Black
HB47PBL	Panel Grill Kit - Black

LOG SETS/ROCK KITS: (Required for each unit)

LOGF36	Log Set - 7 pce. - Fibre Split
MQROCK1	Rock Set
MQRSP1	Rock Platform, Supports, Rocks and 4 Screws (MQHBZDV4736)

Fireplace Wall Mount Finishing Surround for CVCK Kits

MQHB47SWCCBL	Surround Concave Black (Coverage 48 3/4" H x 61 7/16" W)
MQHB47SWCCPW	Surround Concave Pewter (Coverage 48 3/4" H x 61 7/16" W)
MQHB47SWCVBL	Surround Convex Black (Coverage 48" H x 50 7/16" W)
MQHB47SWCVPW	Surround Convex Pewter (Coverage 48" H x 50 7/16" W)

ACCESSORIES

Fireplace Surrounds

HB47BL	Surround - Black (Coverage 42 5/8" H x 50 1/8" W)
HB47SAB	Surround - Antique Brass (Coverage 42 5/8" H x 50 1/8" W)
HB47SCR	Surround - Chrome (Coverage 42 5/8" H x 50 1/8" W)
HB47SPB	Surround - Polish Brass (Coverage 42 5/8" H x 50 1/8" W)
HB47SLAB	Surround Slim Line - Antique Brass (Coverage 42 3/8" H x 48 3/8" W)
HB47SLCR	Surround Slim Line - Chrome (Coverage 42 3/8" H x 48 3/8" W)
HB47SLPB	Surround Slim Line - Polish Brass (Coverage 42 3/8" H x 48 3/8" W)
HB47SLBL	Surround Slim Line - Gun Metal Black (Coverage 42 3/8" H x 48 3/8" W)

Designer Doors for 47" Fireplaces - Operative

HB47DDA1BL	Designer Door Arch - Series 1 - Black
HB47DDTA1A	Trim - Antique for Designer Arch - Series 1
HB47DDTA1C	Trim - Chrome for Designer Arch - Series 1
HB47DDTA1P	Trim - Polish Brass for Designer Arch - Series 1
HB47DDS1BL	Designer Door Straight - Series 1 - Black
HB47DDTS1A	Trim - Antique for Designer Straight - Series 1
HB47DDTS1C	Trim - Chrome for Designer Straight - Series 1
HB47DDTS1P	Trim - Polish for Designer Straight - Series 1

Overlays

HB47ADTH	Arch Door Top Half Black
HB47ADDX	Arch Door Frame - Deluxe Black
HB47ADDA	Arch Door Frame - Double Arch Black
HB47ADDD	Arch Door Frame - Double Door Arch Black

Child Safety Screens

HB47CSS	Child Safety Screen - 47" DV Fireplaces
HB47PSK	Pull Screen for CVCK

Replacement Burner Assembly

4736HB-BNGSI	BURNER ASSEMBLY - NATURAL GAS C/W VALVE SYSTEM (MQHBZDV4736N)
4736HB-BLPSI	BURNER ASSEMBLY - LIQUID PROPANE C/W VALVE SYSTEM (MQHBZDV4736LP)

Accessories

Z36FK	Fan Kit w/Variable Speed Wall Mount Control (Temperature Sensing)
Z1MT	Thermostat Millivolt Wall Mount
Z80PT	Thermostat Programmable Digital Millivolt Wall Mount (1F80-40)
Z1RC	Remote Control Millivolt (On/Off with LED) (Model I)
ZART	Remote Control Thermostat Millivolt (Model K)
RMCBN	Remote Control - Natural Gas (On/Off, Hi/Lo Flame Adjustment)
RMCBP	Remote Control - Liquid Propane (On/Off, Hi/Lo Flame Adjustment)
DCHS	Remote Control Heatshield
VLBIT4	Log Bits - Large Four Piece Kit
VLBIT6	Log Bits - Small Six Piece Kit

Refractory Liner

HB47PRL	Porcelain Reflective Liner
HB47RLT	Refractory Liner Traditional
HB47RLH	Refractory Liner Herring Bone

Valve System Parts - New Top convertible SIT

1001-P136WR	Thermopile GOAI-524
1001-P069SI	Electrode sparker 915.069 TC SIT
1001-P216SI	Thermocouple 290.216 TC SIT
1001-P167SI	#Orifice Pilot LP 977.167 SIT
1001-P165SI	#Orifice Pilot NG 977.165 SIT
1001-P714SI	#Pilot Burner NG 190.714 CONVERTIBLE, SIT
1001-P713SI	#Pilot Burner LP 190.713 CONVERTIBLE, SIT
1001-P633SI	#Valve 820.651 SIT LP, HI/LO
1001-P634SI	#Valve 820.652 SIT NG, HI/LO

Miscellaneous Parts

1000-150GE	#Silicone GE RED IS806 #736
1000-150MP	#Hi-Temp Mill Pac Sealant 840099
1000-214	#Piezo Ignitor 1244-17 MARK 21
1000-215	#Pal Nut (18MMX1.5MM)BLK (1364.03)
1000-218	#Switch Ivory (1451/001)
1000-227	#Cover Ivory (86001/001)
1000-255	#Orifice Brass - (State Size)
1000-EMBER	#Moon Rock
2000-080	#Thermodisc 2450 (For Blower)
2000-081	#Blower Motor QLN65/2400
1000-085	#Control Variable Speed KBWC-13BV
1000-306	Thermalcord - Adhesive Back for Door Frame
47HB-311	Tempered Low E Glass - for model HBZDV4740 model and MQHBZDV4736
36HB-123	Upper Door Spring

Conversion Kit (Sit Valve Only)

4740-CKLP	LP Conversion Kit for HBZDV4740, MQHBZDV4736
4740-CKNG	NG Conversion Kit for HBZDV4740, MQHBZDV4736

Kingsman Fireplace Venting

Catalog

Number	Description
ZDVHSK	Horizontal Vent Starter Kit - 3 FT Length Horizontal Vent Termination, Wall Thimble, 36" Flex Pipe, Mill Pac, screws/washers, springs.
ZDVHSK5	Horizontal Vent Starter Kit - 5 FT Length Horizontal Vent Termination, Wall Thimble, 60" Flex Pipe, Mill Pac, screws/washers, springs.
FDVVT40	Vertical Vent Termination converts from 15' -40' to 15' and under
FDVHT	Horizontal Vent Termination
FDVHSQ	Horizontal Square Termination
ZDVST	Horizontal Snorkel Termination (34" Tall, 24" Center to Center)
FDVHSC	Safety Cage for Horizontal Termination
ZDVAIS	Attic Insulation Shield
ZDVVOS	Offset Support
ZDVFS	Firestop Spacer
ZDVRS	Roof Support
ZDVWT	Wall Thimble (Horizontal Venting)
ZDVSSLR	Siding Shield - Large Return
MDV38IS	Insulation Sleeve for Low Enclosure

ZDV48GP	Galvanized Pipe 7" Dia. x 48" (Vertical Installations)
ZDVAAF	Flashing 7" c/w Storm Collar (1/12 to 7/12)
ZDVAF2	Flashing 7" c/w Storm Collar (8/12 to 12/12)
ZDVAF3	Flashing 7" c/w Storm Collar Flat
ZDV7SC	Storm Collar 7"
ZDVFK5	Flex Kit (4" & 7" Dia.) x 2.5' (Unexpanded) 5' Expanded
ZDVFK8	Flex Kit (4" & 7" Dia.) x 4' (Unexpanded) 8' Expanded
ZDVFK20	Flex Kit (4" & 7" Dia.) x 10' (Unexpanded) 20' Expanded *Kits are complete with spring stand-offs, sili cone.
ZDV4FC	Flex Connector 4" Diameter
ZDV7FC	Flex Connector 7" Diameter
ZDV4SS	Spring 4" Standoff Spacer
ZDVDFEA	Simpson Dura-Vent Fireplace Adapter (for ZDV33/36/42/47, ZDV6000, MDV30/38 & HB models)
ZDVHKSQ	Horizontal Square Termination Vent Starter Kit - 3 FT Length Horizontal Vent Termination, Wall Thimble, Wall Thimble, 36" Flex Pipe, Mill Pac
ZDVHKSQ5	Horizontal Square Termination Vent Starter Kit - 5 FT Length Horizontal Vent Termination, Wall Thimble, Wall Thimble, 60" Flex Pipe, Mill Pac
FDVHSQ	Horizontal Square Vent Termination

CLEARANCES - MQHB36/42/47 - Mantels & Surrounds

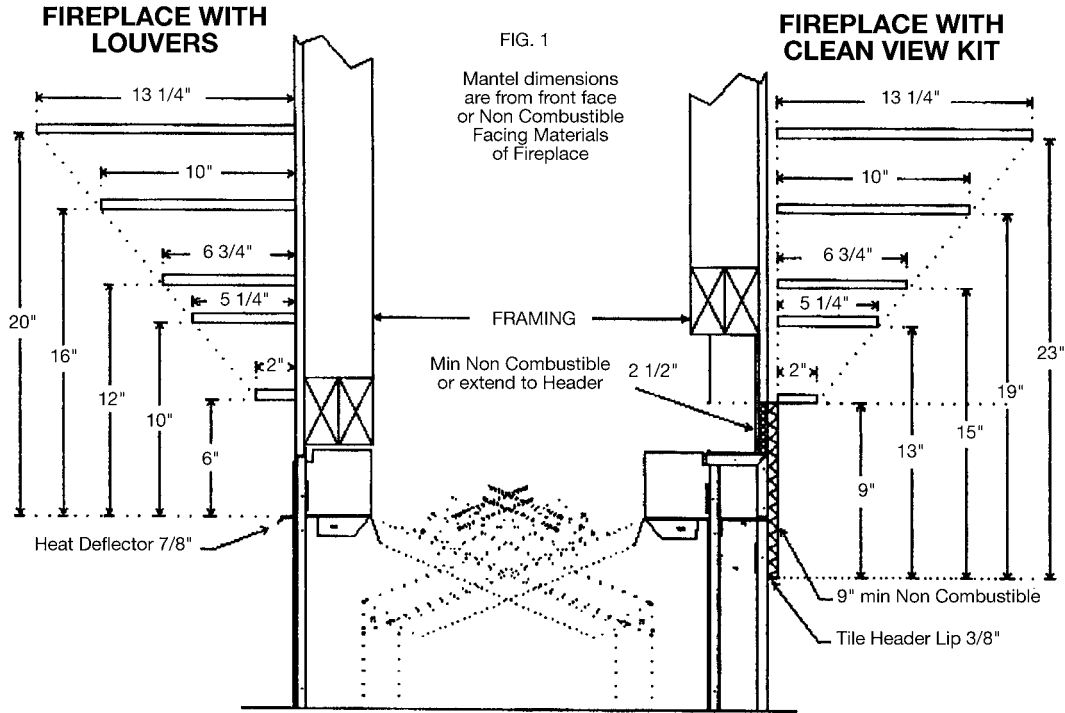

Warning: Combustible objects must not be placed on a non-combustible mantel unless the non-combustible mantel meets the minimum height and width requirements for a combustible mantel.

FIG 2

MQHBZDV Fireplace with CLEAN VIEW KIT and MQHBSW SURROUND

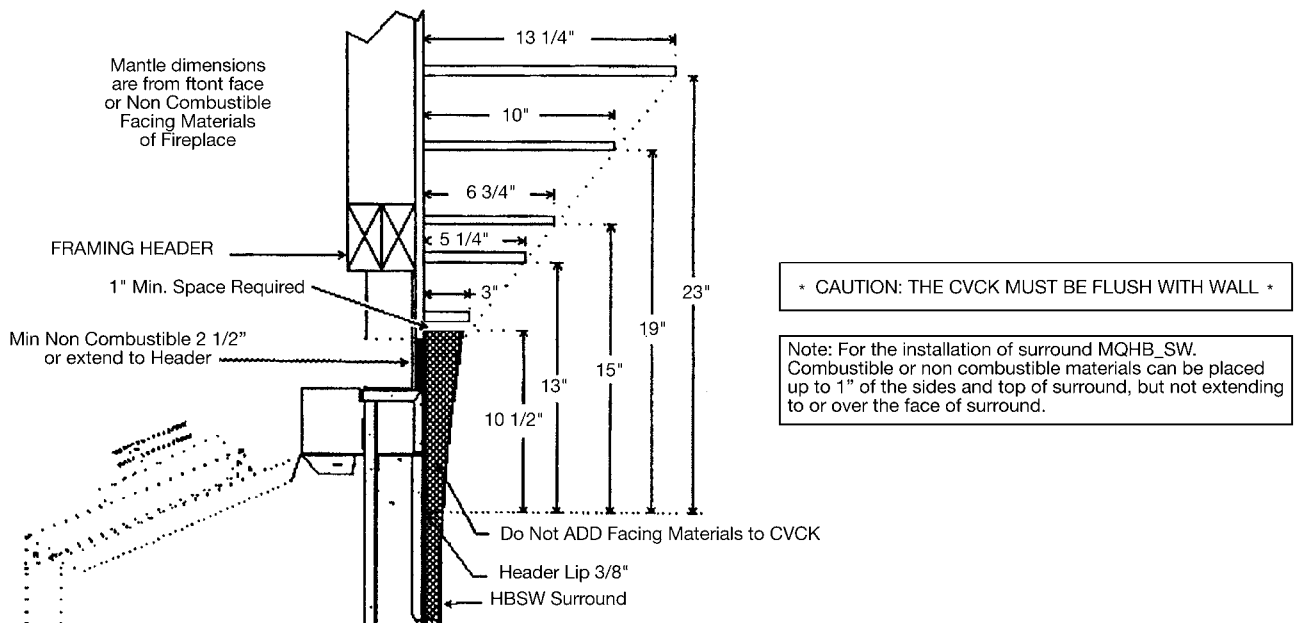

Mantel Leg Clearances

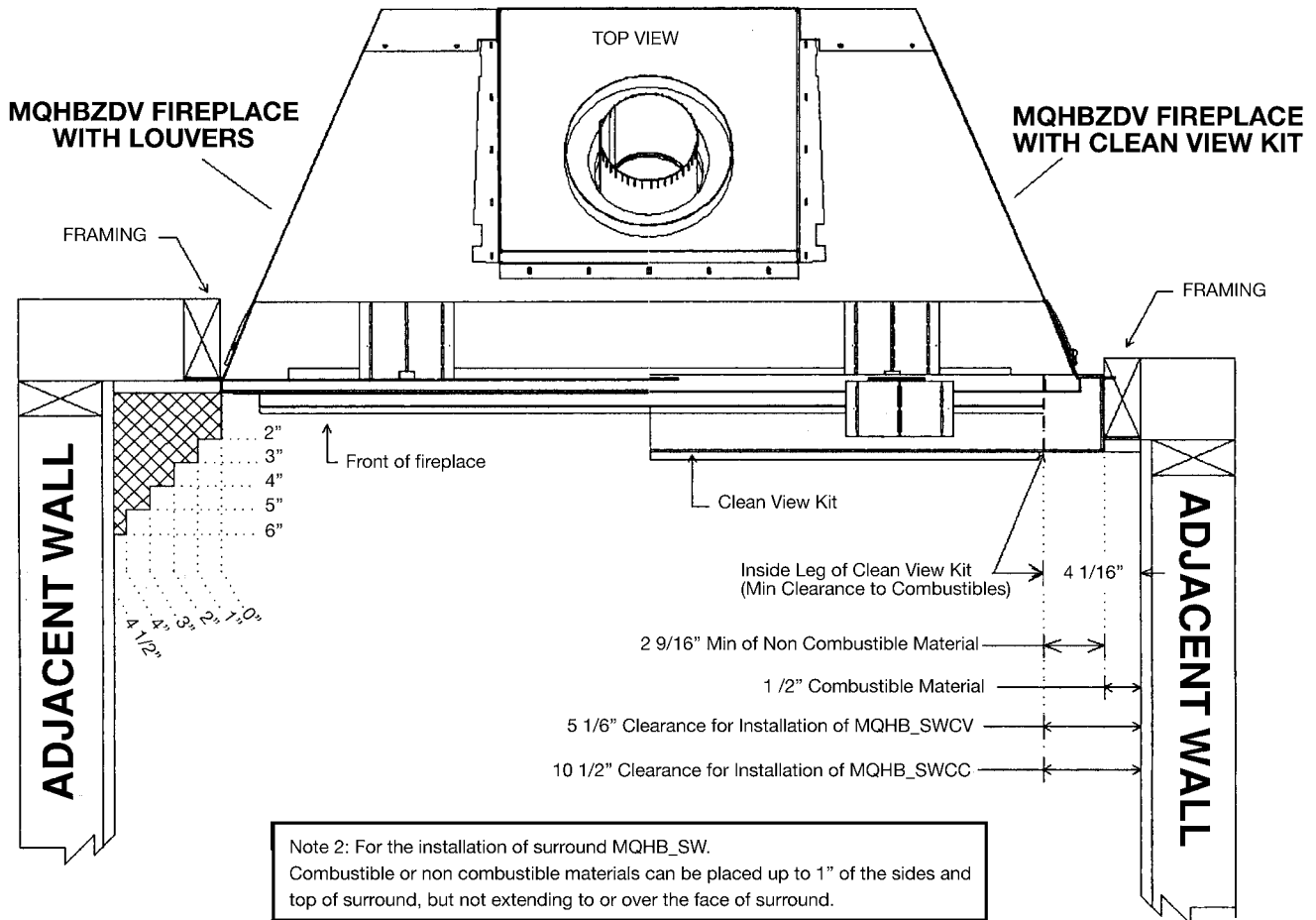

Mantels

Depending on the depth of the fireplace mantel, it may be installed higher or lower from the top of the fireplace opening. See drawings for proper installation height of your combustible mantel. Non-combustible mantels may be installed at any height above the fireplace opening except when using MQHBSW.

Non combustible materials such as brick, tile, etc. can extend up to or over the front face of the fireplace (NO PORTION OF GRILL AREA OR DOOR AREAS CAN BE COVERED) except where designer clean view kit is used.

Combustible material can extend flush to unit up to the top, bottom and sides of fireplace to stand-offs.

For COMBUSTIBLE materials extending in front of fireplace consult (Mantel and Mantel Leg Drawings).

Surrounds

If installing wide or slim line surrounds, the finish materials must be flush with the front facing of the fireplace.

Note: When using paint or lacquer to finish the mantel, such paint or lacquer must be heat resistant (250°F) to prevent discoloration.

MQSW Wall Mount Surround Dimensions

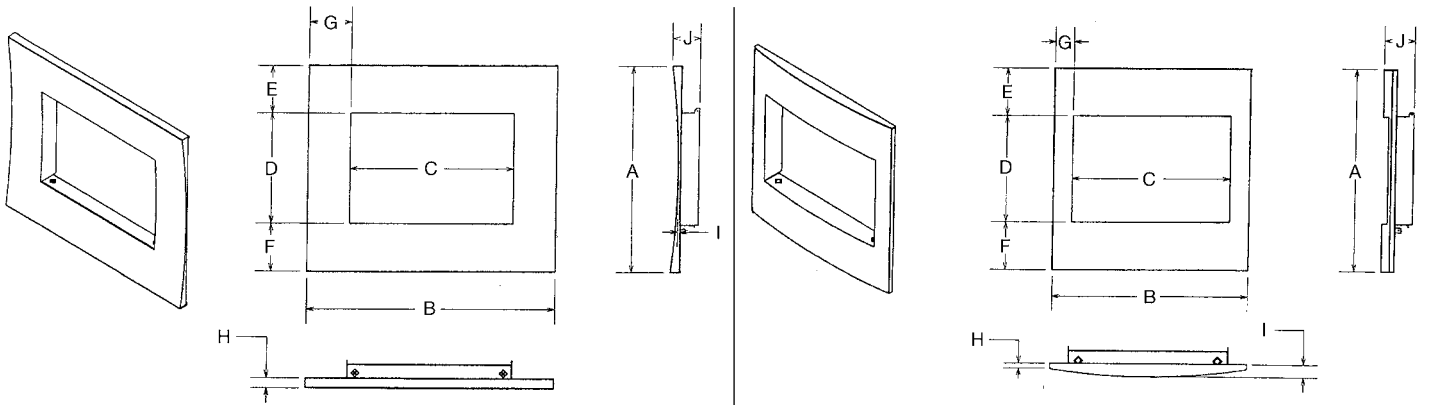

Concave	A	B	C	D	E	F	G	H	I	J	L
HB36	40 1/2	49 1/2	32 1/2	21 5/8	9 1/2	9 1/2	8 1/2	2 1/2	5 1/2	32 7/16	
HB42	42 3/4	55 7/16	36 7/16	23 3/4	9 1/2	9 1/2	9 1/2	2 1/2	5 1/2	36 7/16	
HB47	48 3/4	61 7/16	42 7/16	29 3/4	9 1/2	9 1/2	9 1/2	3	1	6 1/2	42 7/16

Convex	A	B	C	D	E	F	G	H	I	J	L
HB36	41	40 1/2	32 7/16	21 5/8	9 1/2	9 1/2	4	1 3/16	2 13/16	6 1/8	32 7/16
HB42	42 15/16	44 5/16	36 7/16	23 3/4	9 1/2	9 1/2	4	1 3/16	3 1/8	6 7/16	36 7/16
HB47	48	50 7/16	42 7/16	29 3/4	9 1/2	8 3/4	4	1 3/16	3 3/4	7 1/8	42 7/16

Installation of MQ Wall Mount Surrounds

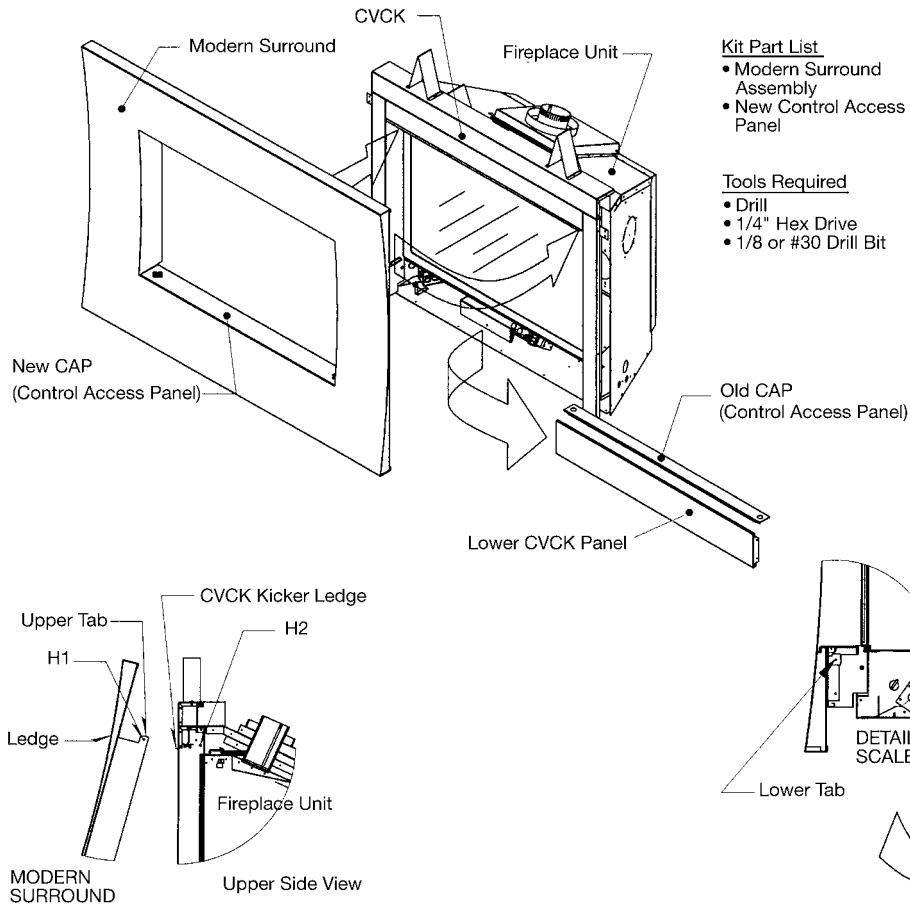

Kit Part List

- Modern Surround Assembly
- New Control Access Panel

Tools Required

- Drill
- 1/4" Hex Drive
- 1/8 or #30 Drill Bit

Remove the old CAP (Control Access Panel), and the Lower CVCK panel by unscrewing the two support screws and drilling out the two rivets.

Remove the two upper CVCK mounting screws located at H2 as shown in the figure below. **IMPORTANT: KEEP ALL FOUR (4) SCREWS TO REMOUNT THE MODERN SURROUND ASSEMBLY.**

Slightly tilt the Modern Surround assembly so that the upper tab will clear the CVCK door opening.

Slide the Modern Surround into the CVCK and align the holes H1 and H2. Please note that the ledge of the Modern Surround should rest on the CVCK Kicker Ledge.

Using the previously removed screws, secure the upper tab of the Modern Surround into the CVCK frame.

Swing lower portion of the Modern Surround into the CVCK and align the mounting holes on the Lower Tab with the holes on the CVCK Side Frame.

Using the previously removed screws in Step 1, secure the Lower Tab to the CVCK side frame.

Replace the old CAP with the new CAP that accompanied the Modern Surround kit.

Check Installation to make sure the Surround and CVCK is secure.

Fan Installation for HBZDV 36/42/47

Fan Installation instructions for HBZDV36/42/47 with or without CVCK (Clean View Circulating Kit)

Note: INSTALL FAN KIT BEFORE INSTALLING OPTIONAL CVCK (Clean View Circulating Kit).

If CVCK has been installed into Framing additional access is provided by removing screws from bottom panel of CVCK. See INSTALLING CLEAN VIEW KIT (CVCK).

- Slide fan housing into unit and place over 2 Fan Retainer tabs. Tabs are pre punched and bent up. Rubber grommets at the base of the fan should fit snugly over the tabs. *Note: When installing fan, lay the fan on its back and slide into the Fireplace lengthwise. Once inside the fan can be stood upright and slid behind the valve for placement.
- Note: For Fan Disc installation HBZDV units have been installed with a sliding track system. Install the Thermomdisc provided with the Fan Kit. Place thermomdisc into sliding assembly, Fig 1, and attach 2 leads exiting right side of fan housing into thermomdisc. Now slide disc assembly into thermomdisc track, Fig 2. Place swivel handle of disc assembly on track to lock into position. To service disc simply pull swivel handle slide towards you while rotating handle to access disc.

Caution: Label all wires prior to disconnection when servicing controls. Wiring errors can cause improper and dangerous operation.

Verify proper operation after servicing.

Parts List:

- 1 ea. fan comes with 4 ft cord. Two 14' leads (female ends)
- 1 ea variable speed control (wall mount type)
- 1 ea thermomdisc
- 1 thermomdisc mount assembly

- Wire Junction Box to 120v and wall mounted variable speed control. Install a duplex outlet to junction box and plug fan into outlet.
 - Turn the wall switch on (clockwise). Turn fireplace on. Once the sensor in unit reaches operating temperature (approximately 10 to 15 minutes) the fan will turn on. The fan can be switched off if desired by turning the wall switch fully counter clockwise.
 - To set the minimum fan speed. Remove the variable switch from the wall mount. Turn the variable speed wall controller to its minimum setting (fully counterwise). Use the set screw on the side of variable speed controller to increase or decrease the minimum fan speed (lowering minimum fan speed will decrease sound level created by fan)
- Reinstall switch into wall mount and cover with face plate.

Note: To service fan with CVCK kit installed see Removing Burner System in manual. If CVCK is finished with a MQSW Wall Surround, the MQSW may be removed by removing the 4 attachment screws and removing MQSW, allowing access into the bottom of fireplace to service blower.

Electrical Services

All optional fan kits are equipped with a 120V, 60Hz, .4amp blower.

Note: All electric connections are to be made in accordance with CSA Standard C22.1 - Canadian Electrical Code part I or with the National Electrical Code, ANSI/NFPA 70 (latest edition) and/or in accordance with local codes.

WARNING: Electrical Grounding Instructions. This appliance is equipped with a three-pronged (grounding) plug for your protection against shock hazard and should be plugged directly into a properly grounded three-prong receptacle. Do not cut or remove the grounding prong from this plug.

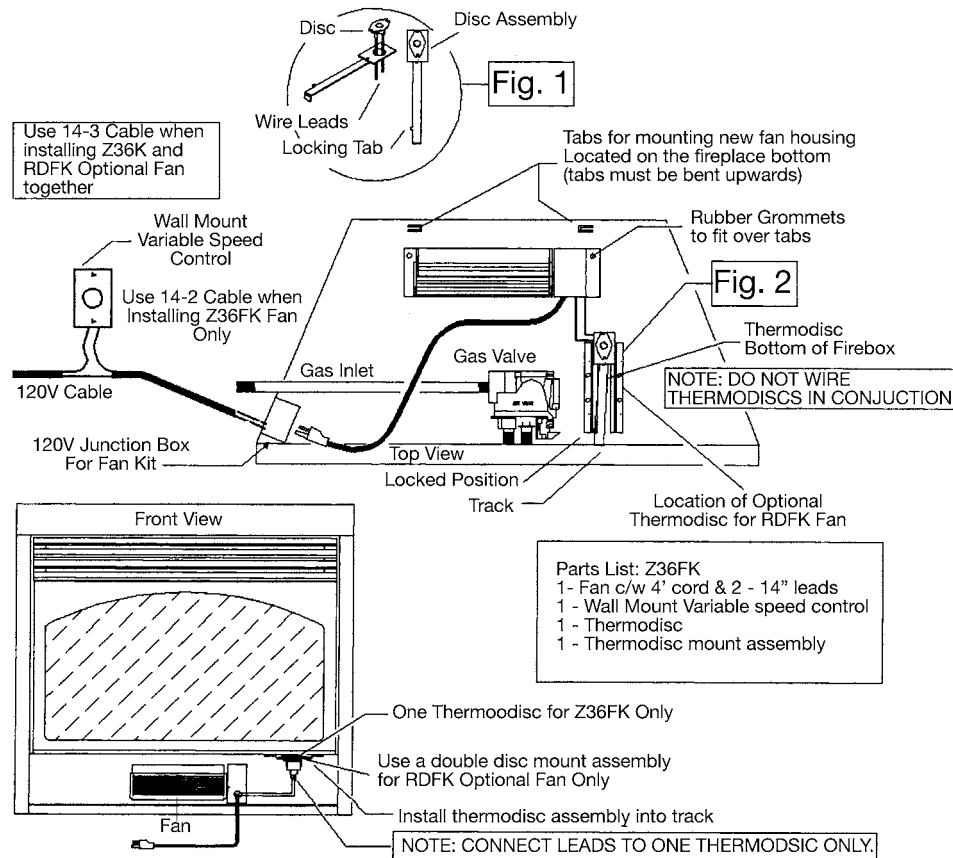

CAUTION – DO NOT ATTACH 120V FAN ASSEMBLY TO MILLIVOLT GAS VALVE SYSTEM

Brick Installation - For Models MQHBZDV3636/MQHBZDV4236/MQHBZDV4736

INSTALLING BRICK PANELS FOR MODEL MQHBZDV3636/MQHBZDV4236/MQHBZDV4736

1. Remove door glass from the unit by unlatching the 2 latches on top of unit.
2. **(MQHBZDV4736 ONLY)**
Using a 1/4" nut driver remove two screws from Brick Panel Filler (#1) and discard brick panel filler. (Ref.1)
3. Remove back Log Holder (#2) by removing three screws from face of Log Holder. The Log Holder will have to be re-installed after the placement of Back Brick Panel. (Ref.1)
4. **(MQHBZDV4736 ONLY)**
Place optional front bridge ledge (#3) in the area front of false bottom.
5. Place rear Brick Panel (#4) up against the rear of Firebox by tilting top of panel towards you and sliding bottom of Panel over the back of burner system.
6. Loosen screws holding brick clip in position. Rotate clip up out of the way and slide side brick (#5) up against rear Brick. Side brick must be flush with side wall of Firebox. Rotate clip down over Brick Panel and tighten screw.

NOTE: Side Brick for MQHBZDV3636 & MQHBZDV4236

Top of side brick has to be tilted forward and hooked over bottom front lip of Firebox first then rotated backward into position.

7. Re-install Log Holder removed in Step 3.
8. Install log set as per instruction and re-install door.

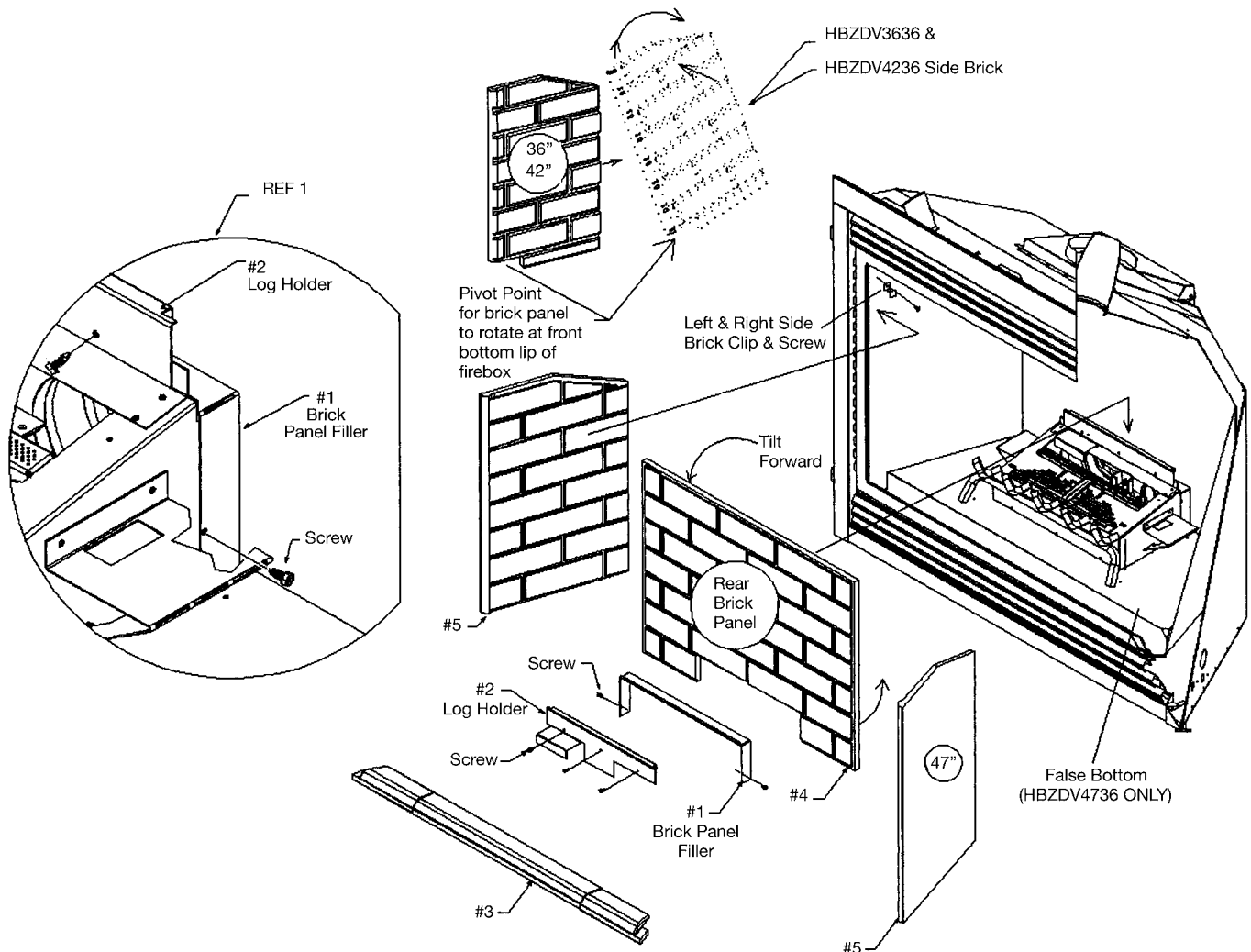

Gas Line Installation

This gas appliance should be installed by a qualified installer in accordance with local building codes and with current CAN/CGA - B149.1 or .2 installation codes for Gas Burning appliances and equipment in Canada and the National Fuel Gas Code ANSI Z223 in the U.S.A.

1. The gas pipeline can be brought in through either the right or the left side of the appliance. A knockout is provided at either location to allow for the gas pipe installation and testing of any gas connection.
2. The gas control inlet is 3/8" NPT. Typical installation layout for rigid pipe is shown at right.
3. When using **copper** or **flex connector**, use only approved fittings. Always provide a union so that gas line can be easily disconnected for burner or fan servicing. See gas specification for pressure details and ratings.
4. When a vertical section of gas pipe is required for the installation, a condensation trap is needed. See CAN/CGA-B149.1 or .2 for code details.
5. For natural gas, a minimum of 3/8" iron pipe with gas minimum pressure of 4.5" w.c. must be used for supply from the gas meter. Consult with the local gas utility if any questions arise concerning pipe sizes.
6. A 1/8" NPT plugged tapings are accessible for test gauge connection both on the inlet and outlet of the gas valve.
7. Turn the gas supply ON and check for leaks. **DO NOT USE OPEN FLAME FOR THIS PURPOSE.** Use an approved leak testing solution.
8. The appliance and its individual shutoff valve must be disconnected from the gas supply piping system during any pressure testing of that system at test pressures in excess of 1/2 PSIG (3.5 KPa).
9. The appliance must be isolated from the gas supply piping system by closing its individual shutoff valve during any pressure testing of the gas supply piping system at test pressures equal to or less than 1/2 PSIG (3.5 KPa).

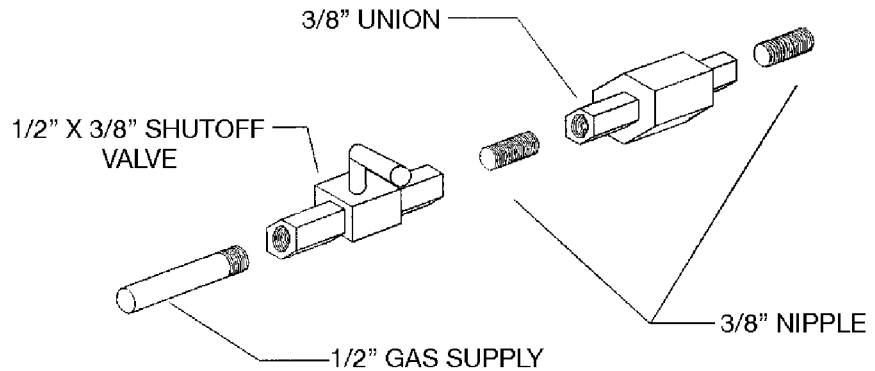

Note: The gas line connection may be made of 1/2" rigid pipe or an approved flex connector. Since some municipalities have additional local codes, it is always best to consult your local authorities and the current CAN/CGA - B149.1 or .2 installation code in Canada or the National Fuel Gas code ANSI Z223.1 in the U.S.A.

For the state of Massachusetts a **T-handle gas shut-off valve** must be used on a gas appliance. This T-handle gas shut-off valve must be listed and approved by the state of Massachusetts. This is in reference to the state of Massachusetts state code CMR238.

Important: Always check for gas leaks with a soap and water solution. Do not use open flame for leak testing.

Gas Specifications

Models	MQHBZDV4736N	MQHBZDV4736LP	MQHBZDV4236N	MQHBZDV4236LP	MQHBZDV3636N	MQHBZDV3636LP
Fuel	Natural	Propane	Natural	Propane	Natural	Propane
Gas Control	Millivolt adjustable	Millivolt adjustable	Millivolt adjustable	Millivolt adjustable	Millivolt adjustable	Millivolt adjustable
Maximum Input	40,000 BTU High	36,000 BTU High	30,500 BTU High	29,200 BTU High	30,500 BTU High	29,200 BTU High
Maximum Output	27,000 BTU Low	30,000 BTU Low	20,600 BTU Low	22,200 BTU Low	20,600 BTU Low	22,200 BTU Low
Orifice Size (0 - 4500 ft)	#31	#49	#36	#51	#36	#51
Air Shutter	5/16" - .312" Open	Fully Open	.187" - 3/16"	.312" - 5/16"	.187" - 3/16"	.312" - 5/16"
Gas Inlet Size	S.I.T. 820 Nova, 3/8" NPT					
Gas Supply Pressure	Minimum	Normal	Maximum			
Natural Gas	5.5"	7"	9"			
Liquid Propane	11"	11"	12"			
Manifold Pressure	Natural Gas		Liquid Propane			
Manifold Pressure High	3.5 IN. W.C./ .87 KPa		10 IN. W.C./ 2.61 KPa			
Manifold Pressure Low	1.6 IN. W.C./ .40 KPa		6.3 IN. W.C./ 1.57 KPa			

Millivolt System, Lighting, & Burner Control

FOR YOUR SAFETY READ BEFORE LIGHTING

WARNING: If you do not follow these instructions exactly, a fire or explosion may result causing property damage, personal injury or loss of life.

BEFORE LIGHTING

- A** This appliance has a pilot which must be lighted by hand. When lighting the pilot, follow these instructions exactly.
- B** Smell all around the appliance area for gas. Be sure to smell next to the floor because some gas is heavier than air and will settle on the floor.

WHAT TO DO IF YOU SMELL GAS

- Do not try to light an appliance.
- Do not touch any electrical switch; do not use any phone in your building.
- Immediately call your gas supplier from a neighbour's phone. Follow the gas supplier's instructions.

- If you cannot reach your gas supplier, call the fire department.
- C** Use only your hand to push or turn the gas control knob. Never use tools. If the knob will not push in or turn by hand, don't try to repair it, call a qualified technician. Force or attempted repair may result in a fire or explosion.
- D** Do not use this appliance if any part has been under water. Immediately call a qualified service technician to inspect the appliance and to replace any part of the control system which has been under water.

LIGHTING INSTRUCTIONS

1. Stop! Read the safety information above on this label.
2. Set the thermostat to lowest setting.
3. Turn off all electrical power to the appliance.
4. Locate valve under the burner assembly.
5. If the control knob is not already in the off position, ie. the word "OFF" in the 9 o'clock position, then push in the gas control knob slightly and turn clockwise to "OFF".
NOTE: Knob cannot be turned from "PILOT" to "OFF" unless knob is pushed in slightly. Do not use force.
6. Wait five (5) minutes to clear out any gas. If you then smell gas. STOP! Follow "B" in the safety information above on this label. If you don't smell gas then go to the next step.
7. Now push in the control knob slightly and turn counter-clockwise to the "PILOT" position.

8. Push in the control knob all the way and hold it. With the other hand push in the red ignitor button until you hear a click. Now observe closely the pilot burner located on the rear center-left hand side of the main burner. If a flame has appeared then continue to depress the control knob for 20 seconds. If the flame did not appear then continue to depress the red ignitor button every 5 seconds until a flame is established. NOTE: If after 30 seconds a flame has not yet been established then turn the control knob back to the off position and repeat steps 5, 6 & 7.
9. Once the pilot has been established hold the control knob in the depressed position for approximately 25 seconds before releasing. If the flame goes out then repeat steps 7 and 8.
10. Now turn the control knob to the "ON" position. The burner will not light unless the wall switch thermostat or remote control is turned "ON" or in the case of the thermostat there is a call for heat.
11. Close the access door and turn all electric power back to the appliance.

TO TURN OFF THE APPLIANCE

1. Set the thermostat to lowest setting.
2. Turn off all electric power to the appliance if service is to be performed.
3. Open the control access door.

4. Push in the gas control knob slightly and turn clockwise to the "OFF" position. Do not force.
5. Replace control access panel.

Recommended Maximum Lead Length (Double Wire) When Using Wall Switch or Thermostat

Wire Size	Max. Length
14 GA.	100 FT.
16 GA.	64 FT.
18 GA.	40 FT.
20 GA.	25 FT.
22 GA.	16 FT.

Pilot Burner Adjustment

1. Adjust pilot screw to provide proper sized flame.

Caution: Do Not Wire 120 Volt Power To Millivolt Switches Or Thermostats.

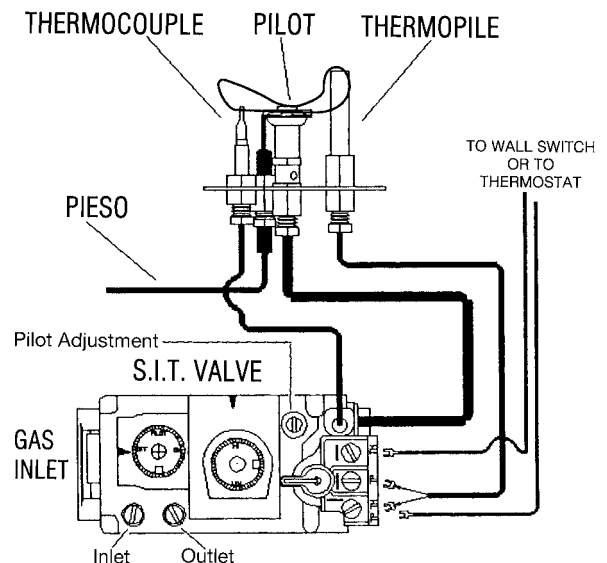

Trouble Shooting The Gas Control System

WARNING: BEFORE DOING ANY GAS CONTROL SERVICE WORK, REMOVE THE GLASS FRONT.

NOTE: Before troubleshooting the gas control system, be sure external gas shut off is in the “On” position.

Problem	Possible Causes	Corrective Action
Spark igniter will not light.	Defective or misaligned electrode at pilot.	Check for spark at electrode and pilot: if no spark and electrode wire is properly connected, replace igniter.
	Defective igniter (push-button)	Using a match, light pilot. If pilot lights, turn off pilot and push the redbutton again. If pilot will not light - check gap at electrode and pilot should be 1/8” to 1/4” to have a strong spark.
Pilot will not stay lit after carefully following lighting instructions.	Defective thermocouple (flame switch where applicable)	Check pilot flame. Must impinge on generator and thermocouple. Clean and/or adjust pilot for maximum flame impingement on generator and thermocouple. Replace thermocouple if pilot will not hold. (Hand tight 1/8 turn on replacement)
	Defective valve magnet.	Replace valve, if pilot won’t hold after the thermocouple is replaced.
Pilot burning, no gas to burner, Valve knob “ON”, Wall Switch “ON”	Wall switch or wires defective	Check wall switch and wires for proper connections. Jumper wire across terminals at wall switch. If burner comes on, replace defective wall switch. If okay, jumper wires, across wall switch wires at valve. If burner comes on, wires are faulty or connections are bad.
	Generator may not be generating sufficient voltage.	Check generator with millivolt meter. Take reading at generator terminals of gas valve. Should read 325 millivolts minimum while holding valve knob depressed in pilot position and wall switch “off”. Replace faulty generator if reading is below specified minimum.
	Plugged burner orifice.	Check burner orifice for stoppage and remove.
	Defective automatic valve operator.	Remove wall switch wires from gas valve. Install jumper wires from top bottom terminals of gas valve. Turn valve on “ON”. If main burner does not light, replace valve.
Frequent Pilot outage problem.	Pilot flame may be too low or blowing (high) causing the pilot safety to drop out.	Clean and/or adjust pilot flame for maximum flame impingement on generator and thermocouple.
Flame lifts off burner and goes out in less than 30 seconds	Inner 4” liner has come off flue or termination, flame is starving for oxygen	Attach 4” liner to flue or termination using screws, silicone and clamps as stated in manual.
Flame lifts off burner on one side while the rest of the flame remains lit.	Improper installation of firebrick. Firebrick is likely leaning.	Be sure to position firebrick against firebox walls and be sure to use brick clips attached to the inner side of firebox.

Burner System Removal for MQHB36/42/47

Removing Burner System / Access Cover for MQHBZDV36/42/47

If fireplace has been installed with optional CVCK (Clean View Circulating Kit) to service fan system or burner system controls, the access cover and burner system pan will have to be removed.

CAUTION: BEFORE STARTING REMOVAL OF PARTS TURN OFF GAS SUPPLY. DISCONNECT 110 VOLTS TO FAN SYSTEM AND DISCONNECT 110 VOLTS TO ELECTRONIC IGNITION BURNER SYSTEM IF APPLICABLE

Access Cover Removal

1. Remove door, logs, brick panels, false bottom, burner grate and burner from firebox.
2. Burner grate is fastened by 2 screws there is one right and left of grate assembly, remove screws and take out grate.
3. **MQHBZDV47 ONLY.** Lift false bottom up from screw alignment points and remove.
MQHBZDV47 skip steps 4 to 8.
4. Remove ember plates right and left of burner, ember plates are held in place by 2 screws each.
5. Loosen screws from burner retainer tabs and slide burner to the left to remove from orifice.
6. Remove rear log holder by removing the 2 screws on each side of log holder.
7. Remove left side log support by removing the 2 screws from side of support.
8. Remove left ember plate support by removing 2 screws at base of support.
9. Remove 10 screws holding access cover in place. Push down on one corner of access cover to break seal of cover, once loose cover can be slid under firebox bottom to expose gas connection.

Removing Burner System

1. Disconnect gas line connection at burner system through access cover opening.
- **CAUTION: ALL WORK SHOULD BE PERFORMED BY A QUALIFIED AND CERTIFIED TECHNICIAN.**
2. Remove extension knobs and wiring from face of gas valve.
 3. Remove false bottom. Undo screws holding back log holder and remove.

Remove screws from perimeter of burner system pan, lift pan at one back corner and rotate pan up from back of firebox. Make sure when tilting up and removing burner system that all fan and valve control wiring is disconnected at this time.

To re-install access cover / burner system remove old Mil Pac sealant and apply new sealant. After new sealant is applied reverse removal procedure to re-install parts.

CAUTION: High temperature sealant has been applied to access cover and burner system pan. New sealant will have to be applied when re-installing access cover and burner system to maintain the integrity of sealed combustion chamber. Mil Pac part #840099 or Kingsman part #1000-150MP sealant can be purchased from your Kingsman retailer or distributor.

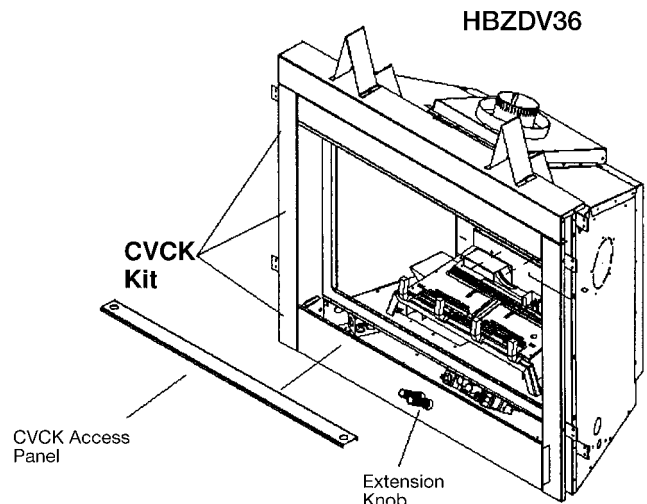

MQHBDV3636 & MQHBZDV4236 Burner System

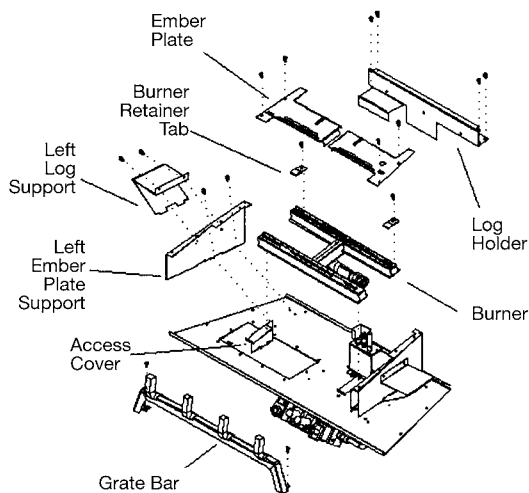

MQHBZDV4736 Burner System

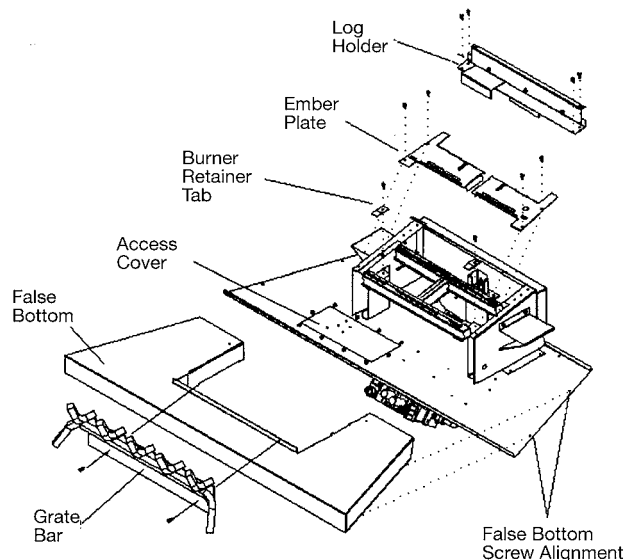

Gas Conversion - MOHB3636/4236/4736

WARNING: This conversion kit shall be installed by a qualified service agency in accordance with the manufacturer's instructions and all applicable codes and requirements of the authority having jurisdiction. If the information in these instructions is not followed exactly a fire, explosion or production of carbon monoxide may result causing property damage, personal injury or loss of life. The qualified service agency is responsible for the proper installation of this kit. The installation is not proper and complete until the operation of the converted appliance is checked as specified in the manufacturer's instructions supplied with kit.

1. Remove ember plates right and left of burner, ember plates are held in place by 2 screws each.
2. Loosen screws from burner retainer tabs and slide burner to the left to remove from orifice.
3. Remove main orifice using a 1/2" wrench and replace with new conversion orifice.
4. Install new pilot orifice (see next page) and Hi/Low valve regulator by following instructions supplied with conversion kit.
5. Adjust the primary air setting to the correct setting as specified in the manual or label plate. To adjust air setting, loosen screw on the side of air mixing tube and rotate to the correct opening using a drill bit or tape measure. Retighten screw.
6. Reinstall ember plates and burner by reversing steps 1 & 2.

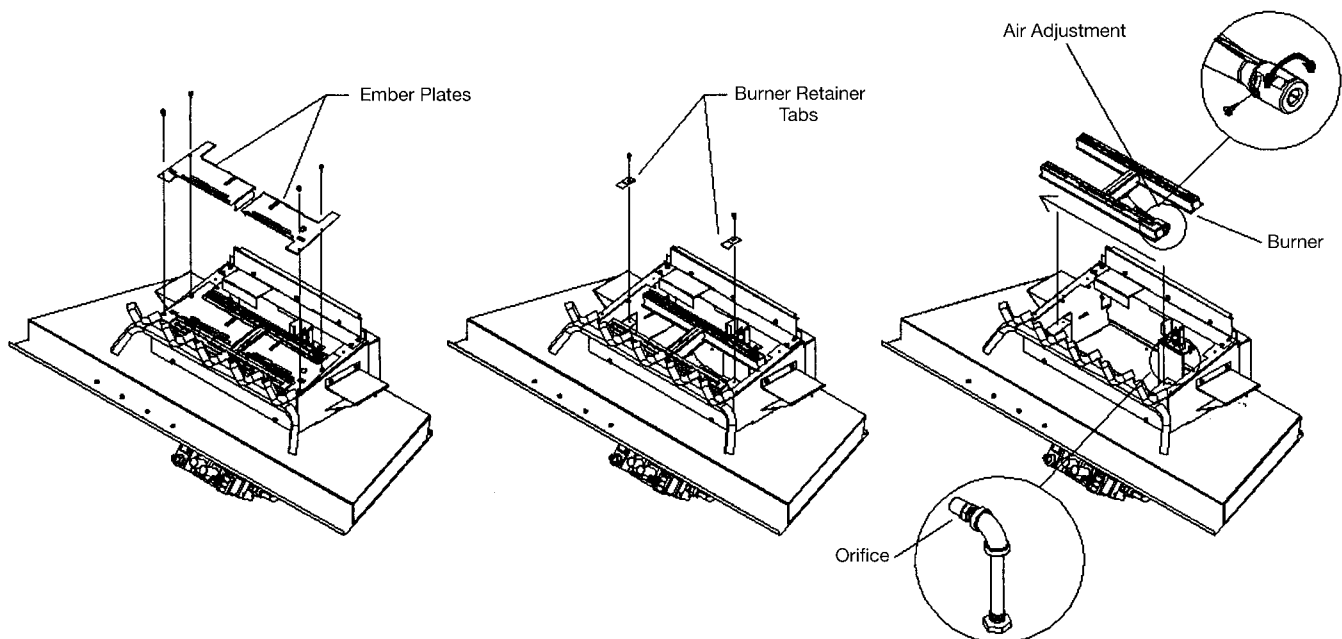

Section B - Installation Instructions

Gas Conversion Kit for Top Convertible Pilot - Series 091065X

Instructions for converting SIT 190 series pilot burner injection from NG to LPG and from NG to LPG Only. This information should be considered as supplemental to the Appliance Manufacturer's Instructions.



WARNING!

The installation of this conversion kit must only be undertaken by a qualified and certified gas appliance installer.

- 1 Shut off the gas supply to the appliance.
- 2 Allow the pilot burner to cool to room temperature.
WARNING: Touching a hot pilot burner can result in injury.
- 3 The pilot hood is held in place by spring pressure. Remove the hood by pulling it directly up from the pilot bracket (1).
- 4 Insert a 5/32" or 4mm Allen wrench into the hexagonal key-way of the injector (2), and rotate it counter clockwise until it is free of the injector journal (3).
- 5 Verify that the new injector is proper for the application. The injector size is stamped on the side of the injector near the top. LPG injectors have a groove machined around their circumference near the top, while NG injectors do not have a groove (5). Refer to the Appliance Manufacturers instruction sheet for the proper injector size.
- 6 Insert the Allen wrench into the end of the injector. Then, insert into injector journal, and rotate the injector clockwise until a torque of 9 in-lbs. is achieved.
- 7 Replace the pilot hood by aligning the tab on the base of the hood with the slot in the side of the pilot journal, and push the hood down, directly onto the pilot bracket (4). The hood must sit squarely on the bracket for proper operation. Check to insure that the hood is properly seated onto the pilot bracket.



Fig. 1



Fig. 2



Fig. 3

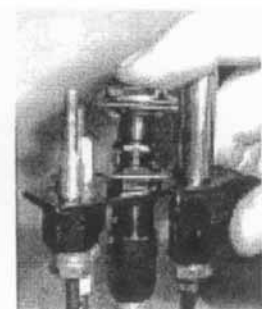

Fig. 4

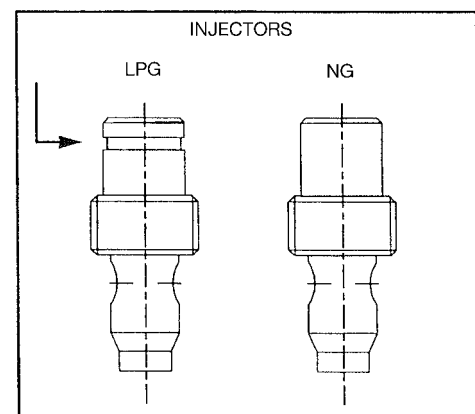

Fig. 5

WARNING!

This conversion kit must only be applied as part of a conversion kit supplied by the appliance Manufacturer for the specific appliance, and type of gas being converted.

INSTALLER NOTICE. These instructions must be left with appliance.

Door and Glass Information

Glass Cleaning

It will be necessary to clean the glass periodically. During start-up, condensation, which is normal, forms on the inside of the glass and causes dust, lint etc. to cling to the glass surface. Also, initial paint curing can deposit a slight film on the glass. It is therefore recommended that initially the glass be cleaned two or three times with non-abrasive common household glass cleansers and warm water. After that, the glass should be cleaned two or three times a season depending on the circumstances.

Cautions and Warnings

- Do not clean when the glass is hot.
- The use of substitute glass will void all product warranties.
- Care must be taken to avoid breakage of the glass.
- Do not operate this fireplace without the glass front or with a broken glass front.
- Do not strike or abuse glass.

Glass Replacement

REPLACEMENT GLASS FOR BOTH DIRECT VENT UNITS

Model Series MQHBZDV4736 use Low E Tempered Glass. Must be 5mm thick.

Only Robax ceramic or coated Neoceram glass may be used for replacement for model MQHBZDV3636, MQHBZDV4236. Must be minimum 5mm thick.

To replace glass, clean all materials from door frame. Scrape off old silicone down to metal. Using a high heat silicone temperature-resistant to 500°F (260°C) apply a continuous bead of approximately 1/32" to all four sides of frame and insert glass with new gasket. Frame should be on flat surface, with a small amount of weight pressing glass into silicone. Let dry approximately 15 to 20 minutes. The door can be re-installed by reversing Steps 1 & 2. Use caution when removing broken glass, wear gloves.

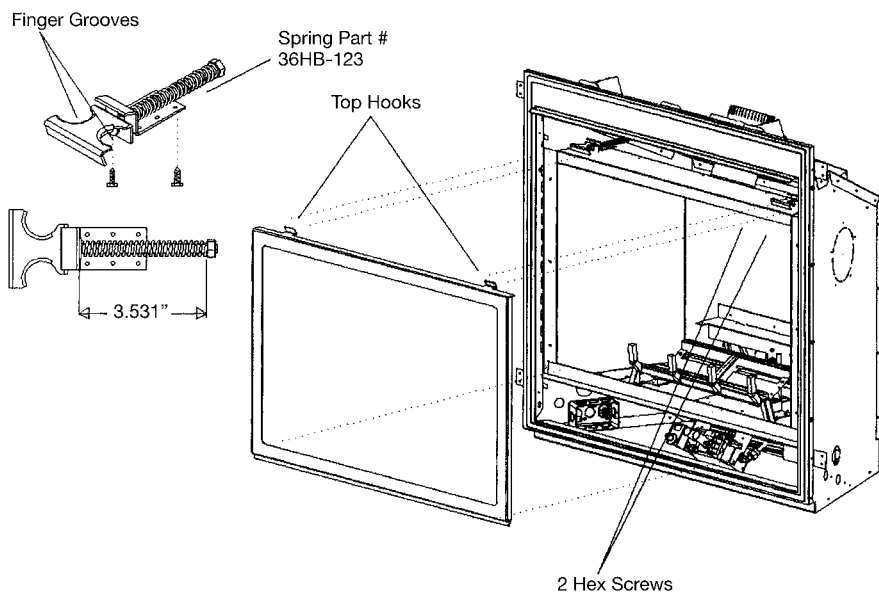

Removal of the Glass Door

1. Remove the door by unlatching the 2 top latches. Simply place 2 fingers in the grooves, pull towards you and lift upwards slightly.
2. Once the top of the door is unlatched, simply pull outwards and lift upwards to unlatch the bottom.
3. When re-installing the door place the bottom of the door in first and secure with Top Latch assembly to the door.

Spring Replacement:

*Over time, spring may need to be replaced if tension is lost.

1. To remove the top latch, remove the 2 hex screws that secure it in place. They are located in the firebox.
2. Once all the screws are removed the latches will slide out of place.
3. There is 1 lock nut per latch. When replacing a spring, tighten the lock nut until 2 threads are beyond the locknut. This is critical for proper tension.

Appliance/Log Reference Chart/Log Placement

The following is a list of models and appropriate log sets that can be used with each model. It is important that the appropriate log set is used with the correct model in order for the appliance to work properly.

Appliance	LOGF36	MQRSP1 MQROCK1	MQRSP2 MQROCK1
MQHBZDV3636N or LP	✓		✓
MQHBZDV4236N or LP	✓		✓
MQHBZDV4736N or LP	✓	✓	

LOG PLACEMENT - LOGF36

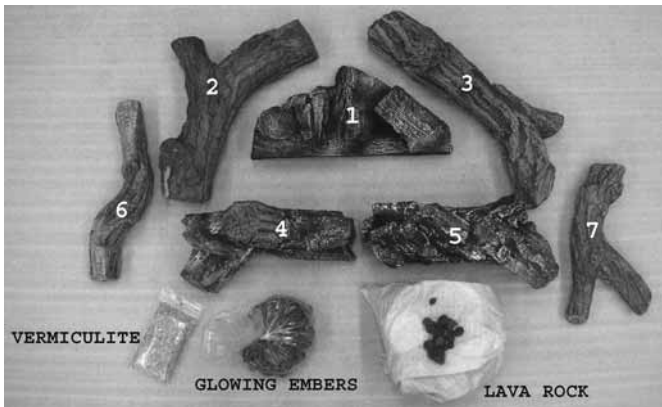

PARTS LIST

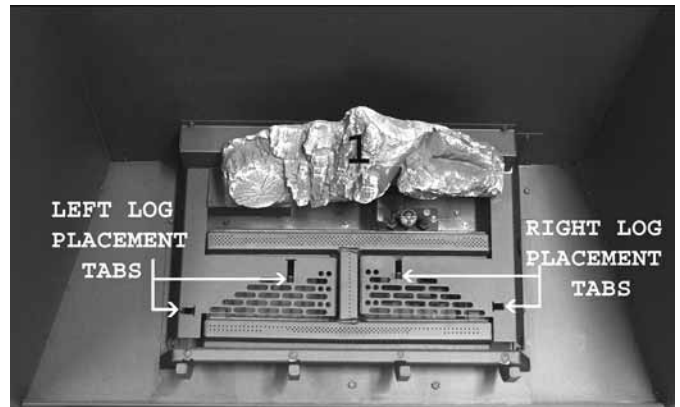

STEP 1: Place log #1 onto rear log holder and center.



STEP 2: Place log #2 onto left side of log. Place log #3 onto right side of log #1.



STEP 3: Locate 2 holes on the bottom of logs #4 and #5. Position them onto left and right log placement tabs.

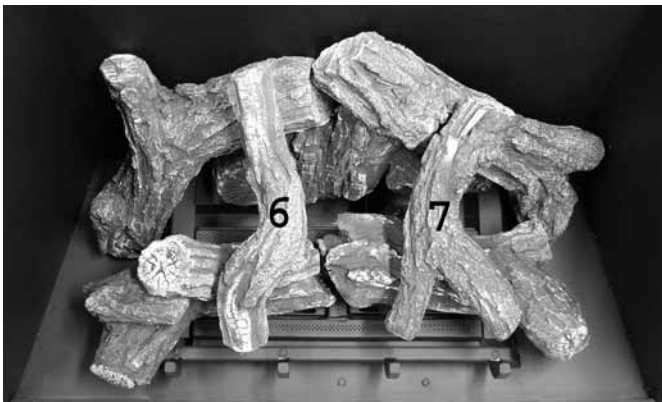

STEP 4: Locate the hole on the bottom of log #6. Place onto the mounting tab on log #2. Locate the 2 holes on the bottom of log #7. Place onto mounting tabs on log #5.



STEP 5: Place glowing embers on the front of the burner tube and ember plates. Place lava rock and vermiculite on the burner pan as shown.
DO NOT PLACE LAVA ROCK AND VERMICULITE ON BURNER TUBE.

MOROCK1/MORSP2 Setup for Models MOHBZDV3636/MOHBZDV4236

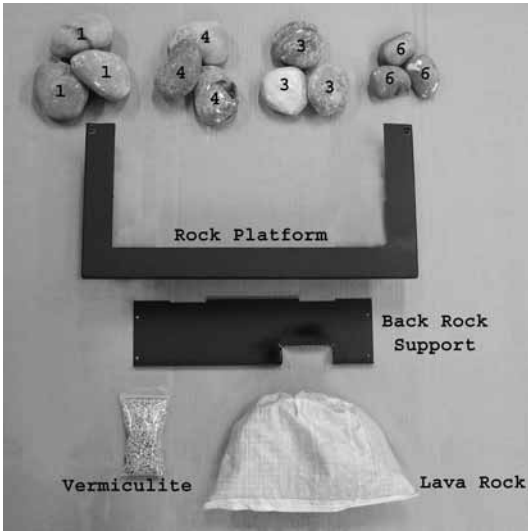

PARTS LIST

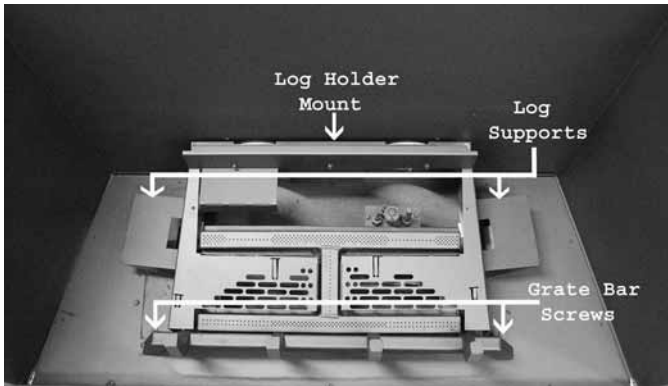

STEP 1: Remove the log holder mount, log supports, and the grate bar.

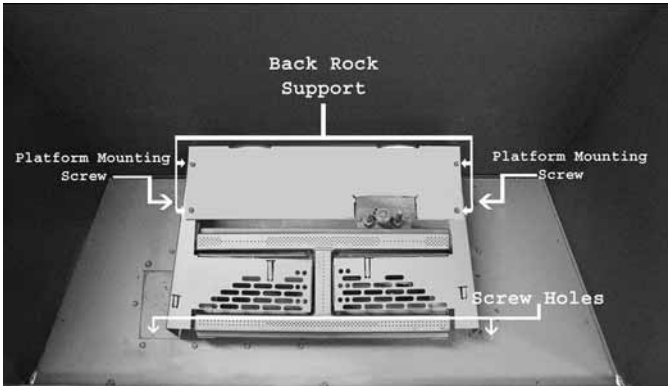

STEP 2: Attach the back rock support with the 4 screws as shown. Replace/reinstall the 2 screws from the grate bar.

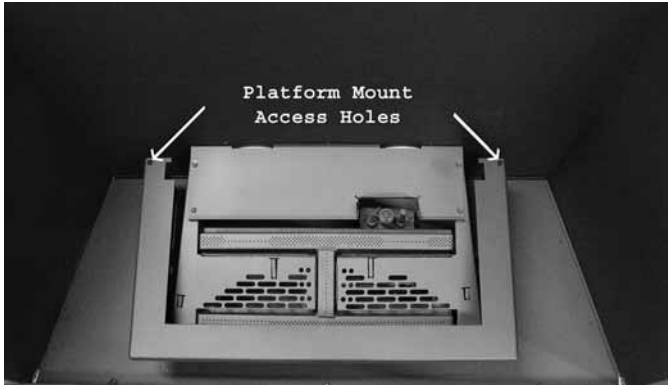

STEP 3: Using the platform mount access holes, attach the rock platform as shown.

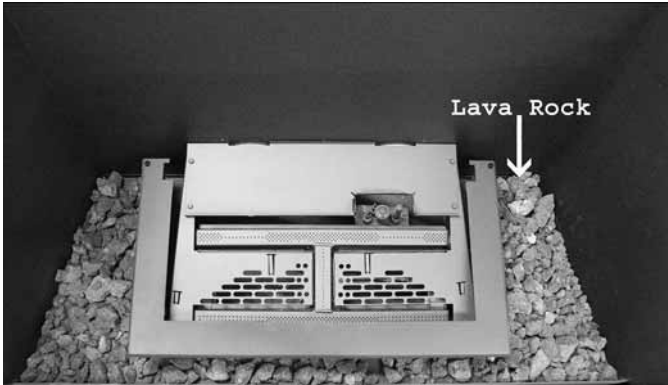

STEP 4: Fill around the rock platform with lava rock. Do not place any lava rock on the burner. Sprinkle vermiculite over top of the lava rock.

MOROCK1/MORSP2 Setup for Models MOHBZDV3636/MOHBZDV4236

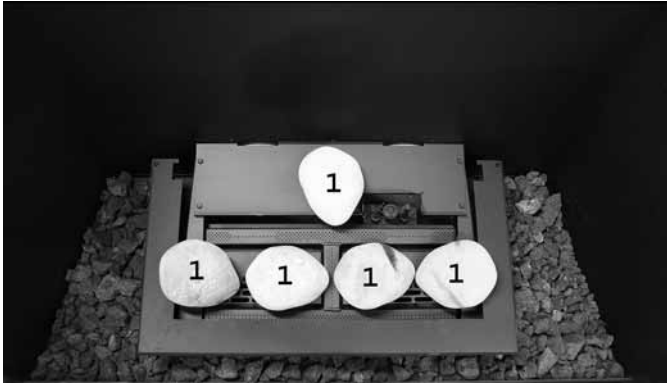

STEP 5: Place rocks #1 onto the burner as shown.

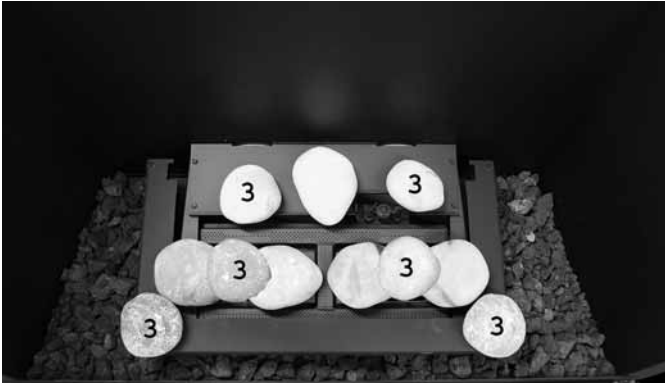

STEP 6: Place rocks #3 onto the burner as shown.

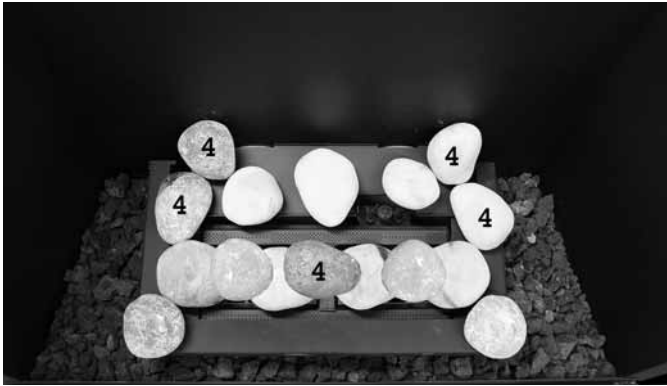

STEP 7: Place rocks #4 onto the burner as shown.



STEP 8: Place rocks #6 onto the burner as shown.



STEP 9: Place remaining rocks #4 and #6 into position as shown.



Finished Rock F2 Setup

Placement of rocks for steps 8 and 9 can be random.

Do not place any of the rocks directly over the burner tubes.

MQROCK1/MQRSP1 Setup for Models MQHBZDV4736

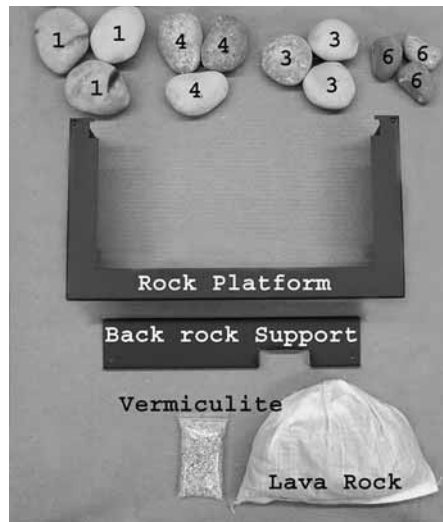

PARTS LIST: Rock #1 - 5 pieces; Rock #3 - 6 pieces;
Rock #4 - 10 pieces; Rock #6 - 9 pieces.

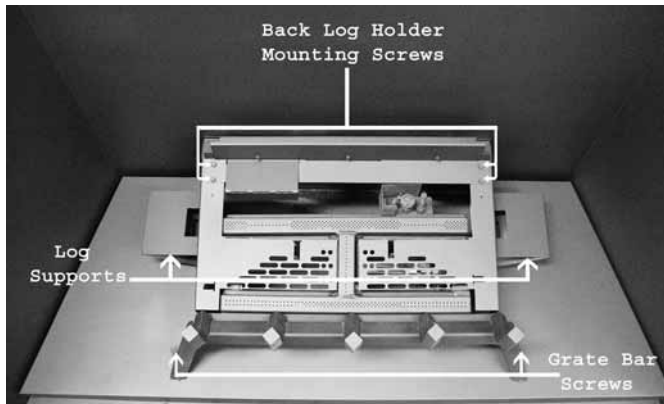

STEP 1: Remove the back log holder, log supports, and the grate bar. Replace/reinstall the 2 screws from the grate bar.

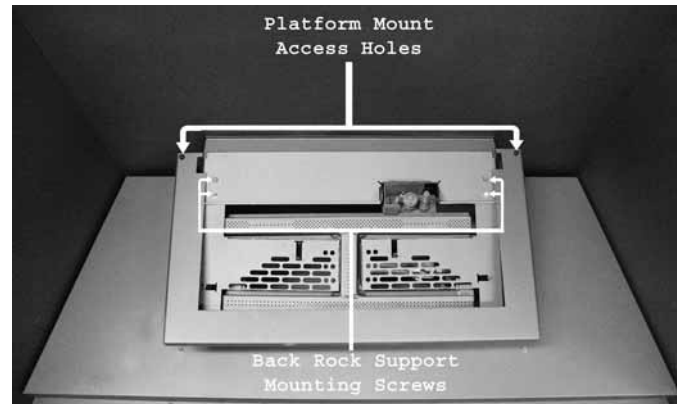

STEP 2: Attach the back rock support using the existing screws from the back log holder. Using the platform mount access holes, attach the rock platform as shown.



STEP 3: Fill around the rock platform with lava rock. Sprinkle vermiculite over top of the lava rock. **Do not place lava rock or vermiculite on top of the burner tube.**



STEP 4: Place rocks #1 onto the burner as shown. **Do not place rocks directly onto the burner tubes.**

MQROCK1/MQRSP1 Setup for Models MQHBZDV4736

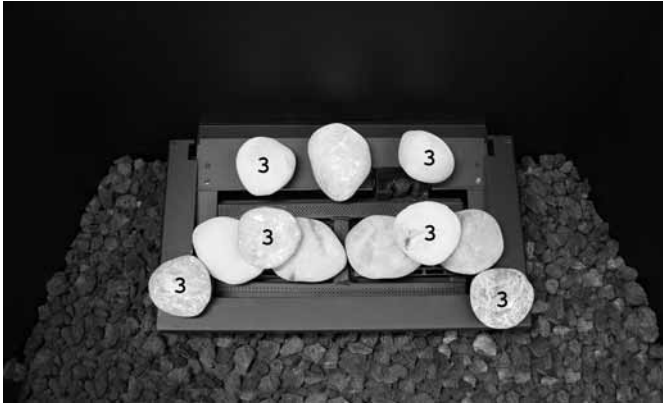

STEP 5: Place rocks #3 into position as shown. **Do not place rocks directly onto the burner tubes.**

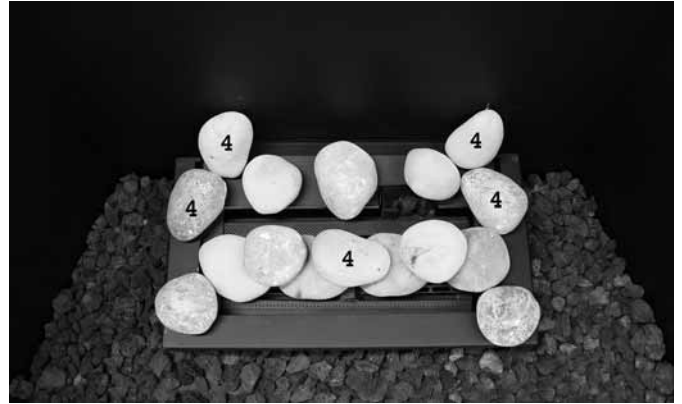

STEP 6: Place rocks #4 into position as shown.



STEP 7: Place rocks #6 into position as shown.



STEP 8: Place remaining rocks #4 and #6 into position as shown.



Finished Rock F1 Setup

Never place any of the rocks directly onto the burner tubes.

Vent Termination

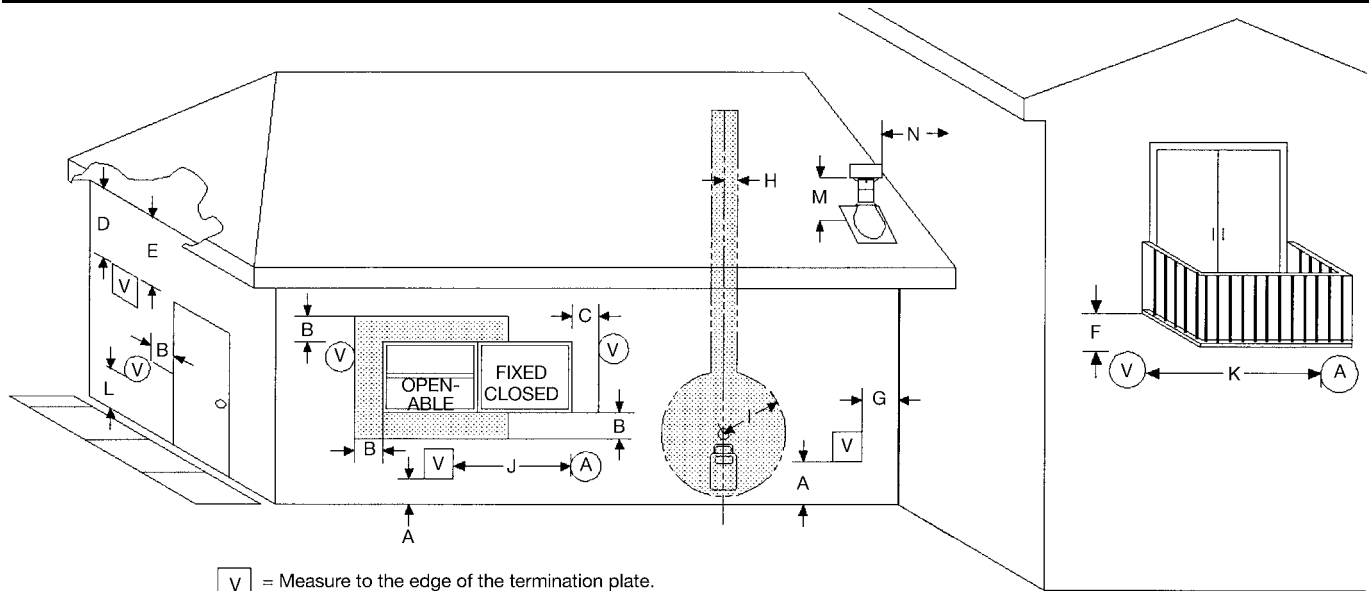

V = Measure to the edge of the termination plate.
V = Measure to the edge of the round termination.

V Vent Terminal

A Air Supply

■ Area Where Terminal Not Permitted.

A - Clearance above grade, veranda, porch, deck, or balcony 12 inches (30cm) minimum.¹⁻²

B - Clearance to window or door that may be opened. 12 inches (30cm) minimum for appliances 100 000 Btuh (30 kW) and lower, in Canada. 9 inches² (23cm) for appliances 50 000 Btuh and lower, in USA.

C - Clearance to permanently closed window minimum 12 inches (30cm) recommended to prevent condensation on window, in Canada. 9 inches² (23cm) for appliances 50 000 Btuh and lower, in USA.

D - Vertical clearance to ventilated soffit located above the termination within a horizontal distance of 2 feet (60cm) from the center line of the termination. 18 inches (46cm) minimum.⁵

E - Clearance to unventilated soffit 12 inches (30cm) minimum.

F - Clearance under veranda, porch, deck or balcony 12 inches¹ (30cm) minimum.⁴ US⁵

G - Clearance from a perpendicular inside wall or outer corner to the edge of the vent terminal plate is 3" (minimum).

H - Clearance to each side of center line extended above meter/regulator assembly 3 feet (91cm) within a height 15 feet (4.5m) above the meter/regulator assembly.

I - Clearance to service regulator vent outlet 3 feet (91cm) minimum.¹ US⁵

J - Clearance to non-mechanical air supply inlet to building or the combustion air inlet to any other appliance: In Canada, 6 inches (15cm) for appliances ≤10,000 Btuh (3kW), 12 inches¹ (30cm) minimum for appliances >10,000 Btuh (3kW) and ≤100,000 Btuh (30kW), 36 inches (91cm) for appliances >100,000 Btuh (30kW). In the USA, 6 inches² (15cm) for appliances ≤10,000 Btuh (3kW), 9 inches (23cm) for appliances >10,000 Btuh (3kW) and ≤50,000 Btuh (15kW), 12 inches (30cm) for appliances >50,000 Btuh (15kW).

K - Clearance to a mechanical air supply inlet 6 feet (1.8m) minimum.¹ in Canada. In USA, 3 feet (91cm) above if within 10 feet² (3m) horizontally.

L - Clearance above paved sidewalk or a paved driveway located on public property 7 feet (2.1m) minimum.³

M - Clearance above highest point of exit on roof 18 inches (45cm).

N - Clearance to perpendicular wall 24 inches (60 cm).

(Recommended to prevent re-circulation of exhaust products. For additional requirements check local codes.)

NOTE: Clearances are to the edge of terminal plate, add 6-3/4" to clearances to arrive at center line.

NOTE: Local Codes or Regulations may require different clearances.

Termination

It is imperative that the vent termination be located observing the minimum clearances as shown. There must not be any obstruction such as bushes, garden sheds, fences, decks or utility buildings within 24" from the front of the termination plate.

Do not locate termination where excessive snow or ice build-up may occur. Be sure to check vent termination area after snow falls and clear to prevent accidental blockage of venting system. When using snow blowers, make sure snow is not directed towards vent termination area.

General Venting Information

The gas fireplace is approved to be vented either through the side wall or vertically through the roof.

This appliance is approved with Kingsman flex vent system and also approved for use with Simpson Duravent Direct Vent System (model DV-GS series), AmeriVent Direct Vent Pipe System and Selkirk Direct Temp.

Kingsman flex vent system can be used with Simpson Duravent Direct Vent termination's (model DV-GS series).

When using Simpson Duravent, AmeriVent Direct Vent pipe, or Selkirk Direct Temp a Kingsman/Duravent adapter must be used.

ONLY VENTING COMPONENTS SPECIFICALLY APPROVED AND LABELED FOR THIS FIREPLACE MAY BE USED.

Venting terminal shall not be recessed into a wall or siding. If finishing the outside wall with vinyl or wood siding it is recommended that a Siding Shield be installed, Part Number ZDVSSLR.

1 - In accordance with the current *CSA B149.1, Natural Gas and Propane Code*.

2 - In accordance with the current *ANSI Z223.1/NFPA 54, National Fuel Gas Code*.

3 - A vent shall not terminate directly above a sidewalk or paved driveway that is located between two single family dwellings and serves both dwellings.

4 - Permitted only if veranda, porch, deck, or balcony is fully open on a minimum of two sides beneath the floor.

5 - Clearance in accordance with local installation codes and the requirements of the gas supplier.

General Vent Installation Information

This gas appliance is approved to be vented either through the side wall or vertically through the roof. **Only Kingsman venting kits and components specifically approved and LABELED for this stove may be used.** This appliance is also approved for use with Simpson-Duravent Direct Vent system (Model DV-GS Series), Ameri-Vent Direct Vent Pipe System, and Selkirk Direct Temp.

SIMPSON DURAVENT, AMERIVENT OR SELKIRK DIRECT TEMP

When using Simpson Duravent, AmeriVent pipe, or Selkirk Direct Temp a Duravent hardpipe adapter must be used (part # ZDVFDA for fireplaces). Follow installation instructions provided by Simpson Duravent/AmeriVent/Selkirk Direct Temp for installation of pipe and adhere to the clearance to combustibles provided in this manual. Apply a bead of Mill Pac high temp sealant to all joints of pipes, adapters and termination, when using Kingsman venting and Simpson Duravent venting.

WARNING: DO NOT mix parts from different systems unless stated in the manual.

Flex Pipe Venting

Flex pipe is shipped in unexpanded length. When installing pipe expand the lengths. Pipe can be expanded to twice their lengths e.g. 4ft. to 8ft. Fully extend pipe and cut off remaining pipe.

Do not use more than 2 couplers to extend short pipes. Single sections are preferred in an installation attaching at the fireplace and termination.

Place the spring spaces provided approximately every two feet to stabilize 4" flex in the center of 7" flex. When forming bends place spring in bend or before and after. (See Fig. 1).

Horizontal runs require support metal straps every 2 feet. In off set installation support straps should be used to stabilize pipe.

Expand 4" and 7" flex pipe to the point that the 7" protrudes approximately 2 to 3 inches past outer wall and the 4" flex protrudes approximately 2 to 3 inches past the 7" flex. See Fig. 1. Attach the 4" pipe to the termination first and secure with sealant and screws then attach the 7" flex to the termination with caulking and screws. Termination may then be moved back to the outer wall and attached to home screwing into the framing. Silicone around termination to waterproof. If siding shield is going to be used attach this using same attaching hole as the top of termination after termination has been caulked for water proofing.

Use Hi Temp Sealant

Apply a bead of mill pac high temp sealant to all joints and use four screws to secure each pipe at fireplace, termination and any joint if joining any sections of pipe.

NOTE: It is critical to the proper and safe operation of this fireplace that on all connections the inner liner and the outer casing are both caulked with liberal amounts of sealant. Do not use any kind of tape or silicone other than that recommended in this manual. Mill Pac Sealant

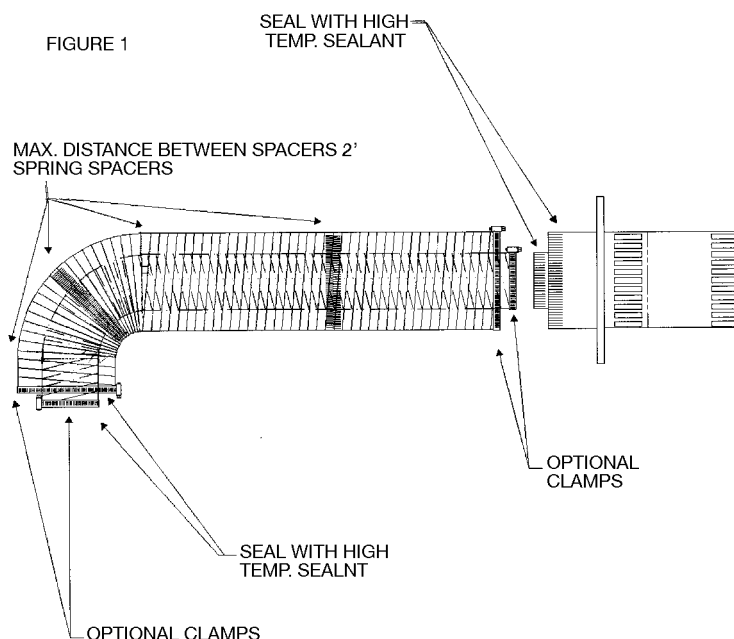

Venting Routes And Components

Since it is very important that the vent system maintain its balance between the combustion air intake and the flue gas exhaust, certain limitations as to vent configurations apply and must be strictly adhered to.

The table showing the relationship between vertical and horizontal side wall venting will help to determine the various vent lengths.

The maximum horizontal run with the 90 degree bend at the fireplace flue outlet is 4 ft/122cm (Figure #1). The maximum horizontal run is 20 ft/6.1 m when the vertical run is 7 ft/2.1m (Figure #2). Note: 1/4" vertical rise is required for every 12" of horizontal run.

The maximum number of 45 degree bends per side wall installation is two (2) in the horizontal run and then you must reduce the length of the horizontal by 18 inches for each 45 degree bend.

The maximum vertical run is 40 ft/12.2 meters.

Special Note: For each 45 degree bend installed in the horizontal run, the length of the horizontal run must be reduced by 18" (45cm). This does not apply if the 45 degree bends are installed on the vertical part of the vent system.

Example: If according to the table, the length of the horizontal run is 10 feet, and two 45 degree bends are required, the horizontal run length must be reduced to 7 feet.

2 additional 90° bends or equals are allowed. The horizontal run must be reduced by 36" per each 90° bend, or 18" per each 45° bend.

Important: Always locate the fireplace in such a way that a minimum of offsets and/or horizontal runs are required. 1/4" vertical rise is required for every 12" horizontal run.

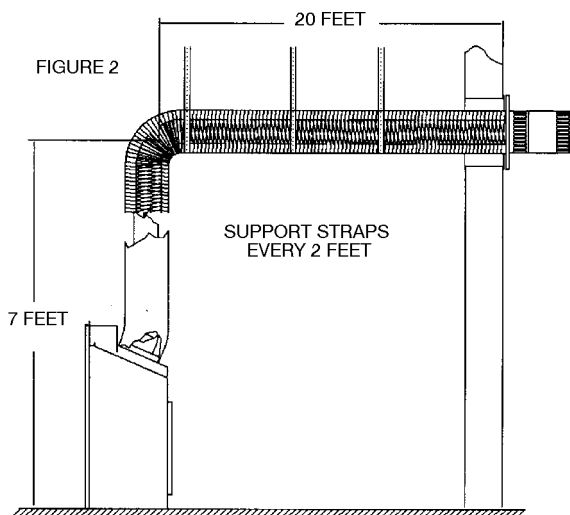
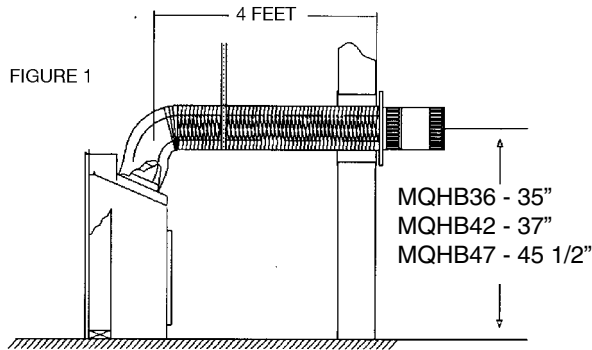

How To Use The Horizontal Vent Table

1. Determine the height of the system and the number of bends required.
2. Having determined the vertical distance determine the maximum horizontal section allowed.
3. Vent table has been established for 90° horizontal/vertical runs. With use of flex pipe distance not having 90° bends will not fall into vent table standards. See Fig. B.

Horizontal Venting Table From Bottom of Fireplace

for venting to a maximum of 40 ft. (12.2 meters)

Total Vertical		Max Total Horizontal	
Feet	Meters	Feet	Meters
4	1.2	5	1.5
5	1.5	8	1.2
6	1.8	12	3.7
7	2.1	20	6.1
8	2.4	20	6.1
9	2.7	20	6.1
10	3.0	20	6.1
11	3.4	20	6.1
12	3.7	20	6.1
13	4.0	20	6.1
14	4.3	20	6.1
15	4.6	20	6.1
16	4.9	20	6.1
17	5.2	20	6.1
18	5.5	20	6.1
19	5.8	20	6.1
20	6.1	20	6.1
25	7.5	15	4.6
30	9	10	3.0
40	12.2	0	0

Example A:

If the vertical dimension from the floor of the fireplace is 6ft, the horizontal run to the wall flange of the vent termination must not exceed 12ft.

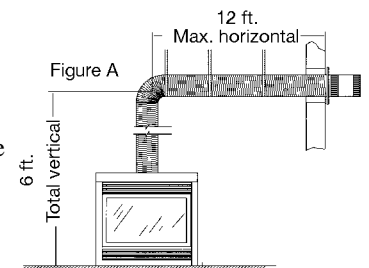

NOTE: The final location of the fireplace must be such that the horizontal vent dimensions fall within those stated on the graph. The Maximum Vertical vent run is 40ft. (12.2 meters).

Important: Minimum clearance between vent pipes and combustible materials is 1 inch (25mm).

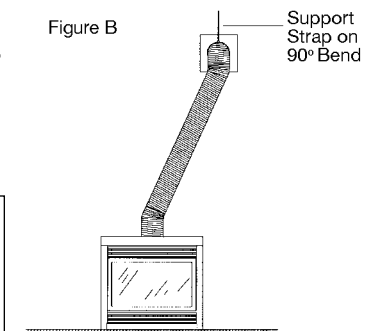

It is recommended for **Propane Horizontal Installations** that the venting should be a minimum of one foot vertical off the flue before the elbow on any horizontal runs of one foot or greater. This allows for cleaner combustion and greatly reduces carboning and cleaning of glass. (Does not apply to Back Flue Models).

Installation Of Side Wall Venting

1. Establish the minimum distance from the bottom of fireplace to centre of vent. Cut a hole through the wall allowing for a 11" x 11" (inside diameter) in combustible walls for wall thimble or an 8" diameter hole in a non-combustible wall (See Figure 1-2-3).
2. Note clearance to combustible as stated on pages
3. Select the approximate vent length, precise measurements are not needed as your flex pipe can be expanded to twice its shipped length for ease of installation.
4. To install wall thimble centre over 11" x 11" (inch) framing from both sides of wall and secure. Route flex vent pipe through wall thimble (See Figure 1).
5. Before joining pipes, apply a bead of high temperature sealant (Mill Pac) to end of pipe. First attach the four inch (4") flue pipe to the vent termination with sealant, and secure with 4 screws provided. At this time make sure the spacer springs are attached to the (4") flex pipe as required. Then attach the seven inch (7") pipe by the same method.
6. Mount vent termination and seal to wall using caulking around the wall thimble to weather proof. After installing the vent termination, double check to make sure the pipe extends properly through wall thimble and into vent termination.
7. Before joining pipes to fireplace flue, apply a bead of high temperature sealant (Mill Pac) to end of pipe. First attach the four inch (4") flue pipe to fireplace with Mill Pac sealant to the flue pipe and secure with 4 screws provided. At this time verify that the spacer springs are attached properly to the (4") flex pipe as required. Then attach the seven inch (7") pipe by the same method.
8. Support horizontal pipes every two (2) feet (61 cm) with metal strap bands. Re-check fireplace to make sure it is levelled and properly positioned and secured.
9. Support vertical pipes to maintain a minimum of 1" or greater clearance to combustibles with metal strapping bands.
10. If finishing the outside wall with vinyl or wood siding it is recommended that a Siding Shield be installed, Part Number ZDVSSLR.

Note: Wall Thimble cover combustible wall up to 11" thick.

Note: Venting termination must not be recessed into wall or siding.

HBZDV3636

Minimum clearance to combustibles on venting is 1" with the following exceptions as follows:
 Top of horizontal 1 1/2".
 Top of 90 degree elbow in an enclosure 42-43" is 3 1/2".
 Top of 90 degree elbow in an enclosure over 43" is 2 1/2".

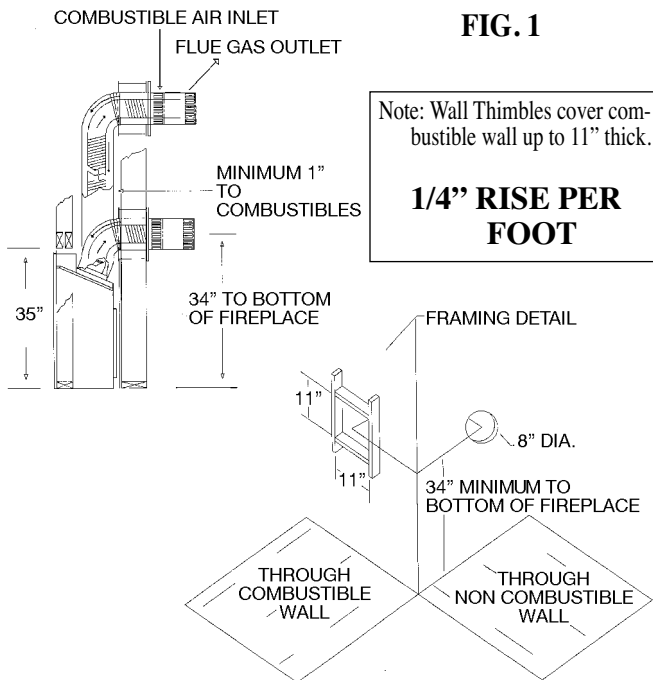

Note: Wall Thimbles cover combustible wall up to 11" thick.
1/4" RISE PER FOOT

HBZDV4736

Minimum clearance to combustibles on venting
 Vertical 1" with Kingsman Vent System
 1 1/4" with Simpson Duravent Systems
 Top of Horizontal Pipe 1 1/2"
 Top of 90 degree bend in Minimum Enclosures of 50 1/2-56 1/2" is 2 1/2" with insulation Sleeve
 Top of 90 degree bend in enclosure over 56 1/2" -60" is 4 1/2" without insulation sleeve.
 Top of 90 degree bend in enclosures over 60" is 2 1/2" without insulation sleeve.

Louvered Unit Shown

1/4" RISE PER FOOT

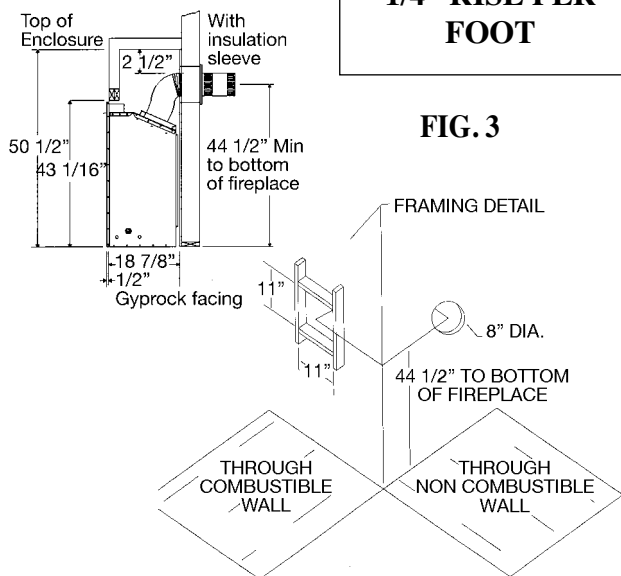

HBZDV4236

Minimum clearance to combustibles on venting is 1" with the following exceptions: Top of horizontal 1 1/2".
 Top of 90 degree elbow in enclosures under 45" to 46" is 5".
 Top of 90 degree elbow in an enclosure over 46" is 2 1/2".

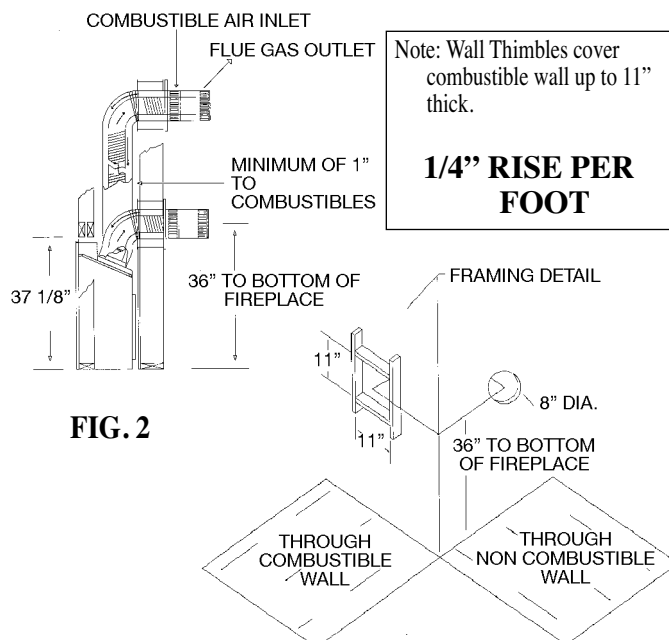

Note: Wall Thimbles cover combustible wall up to 11" thick.
1/4" RISE PER FOOT

Venting Straight Up Through Roof

1. An Attic Insulation Shield must be installed where the vent passes from a lower living space into an attic space where the chimney is not enclosed. It is designed to keep insulation materials away from the chimney. See Fig. 1.
2. When installing the Attic Insulation Shield where the chimney passes from a living space to an attic space, install the shield from below and nail in place using 1" spiral nails.
3. A fire stop must be installed on the bottom side of the joists when passing through a ceiling or floor. If an attic insulation shield is to be used, a fire stop is not required.

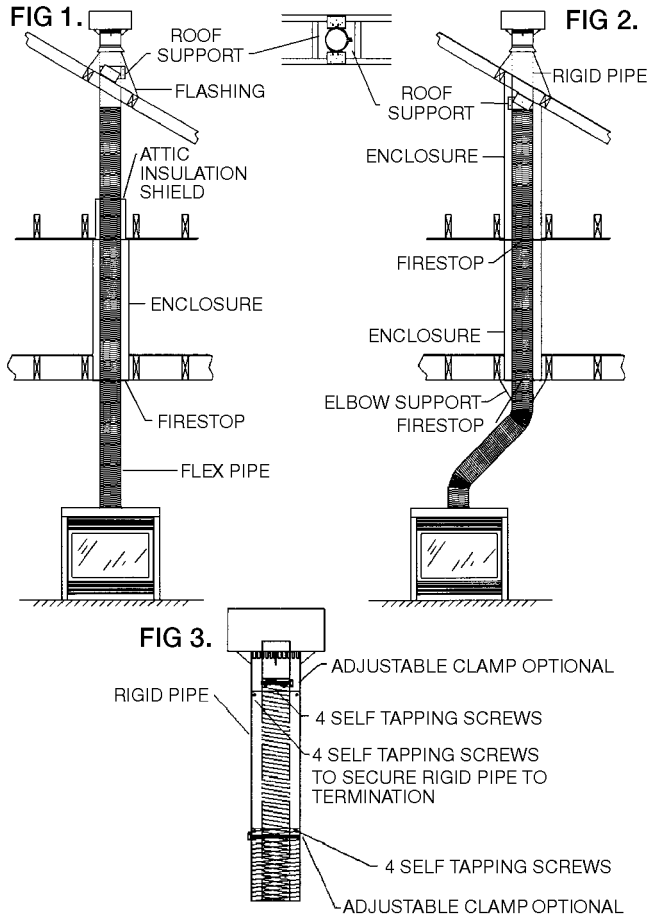

Using Flex Bends

4. Avoid cutting joists by offsetting the flex pipe. See Fig. 2.
5. When using 45° bends a bend support is required directly above the highest bend.
6. When installing a bend in a joist area a minimum of 2 1/2" clearance to combustibles to the top of bend must be maintained, sides and bottom of pipe, a 1" clearance to combustibles must be maintained. If running horizontal through an area a 1 1/2" minimum clearance to the top of the horizontal pipe must be maintained.
7. Maximum vertical height of system should not exceed 40 feet.
8. Use roof support and 7" rigid pipe at roof level. Flex not permitted within roof support.
9. When penetrating the roof a rigid 7" galvanized pipe must be used. Attach the 7" flex to the 7" rigid with high temperature sealant, secure with four screws assuring the flex and rigid pipe are secured. 4" flex pipe must be secured the same way with 4 screws but must penetrate the 4" flex and 4" section of termination. Attach 7" rigid pipe to 7" termination with sealant and screw with 4 sheet metal screws. (See Fig. 3).
10. Vertical termination clearance is 18" (inches) above the roof, measured from highest point of exit on the roof line.
11. Support vertical pipes to maintain minimum of one inch or greater clearances to combustibles.

Roof Flashing

Ensure that you have the proper roof flashing by checking your roof pitch using a level and two rulers, or by using a roof pitch card. See figure below.

Slide a Roof Flashing suitable to your roof slope over the vent. Place the edge of the flashing plate that will be on the higher part of the roof slope under the shingles. Both the sides and the lower edge lay on top of the shingles.

NOTE: At the top edge of the flashing plate, lift the shingles and nail the plate to the roof deck, then cement the shingles to the plate with a suitable waterproof mastic.

Ensure that the chimney is plumb. Square up the flashing plate and nail in place to the roof deck. Use 12 nails with neoprene washers or cover the heads with a suitable waterproof mastic.

Wrap the storm collar around the vent above the flashing. Secure the ends together loosely with nut and bolt supplied. Slide the collar down the vent until it comes in contact with the flashing.

Tighten the bolt and seal the Storm Collar to the vent with a suitable waterproof non-combustible mastic.

The flashing and storm collar should be painted to match the roof shingles. This will extend its life and improve the appearance. Clean, prime and paint with suitable painting products.

Vertical Venting in Cold Climates

In cold climate conditions where temperatures go below -10 degrees Celsius or 14 degrees Fahrenheit, we recommend that the chase be insulated and where the vent pipe be wrapped with an insulated mylar sleeve. This will increase the temperature of the vent and help the appliance to vent properly in cold weather conditions. It is also important in vertical vented direct vent appliances that the appliance be operated daily during the winter months as this will help stop the Termination from freezing up. We recommend using a thermostat set at room temperature to allow the unit to cycle.

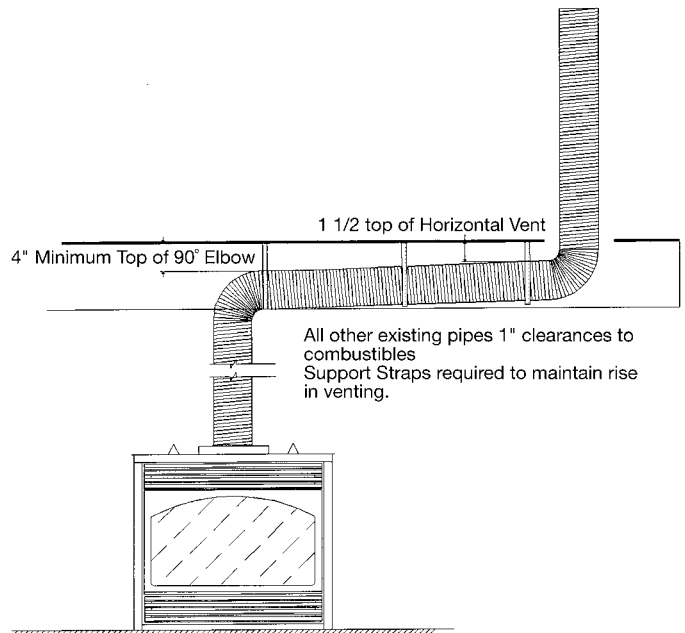
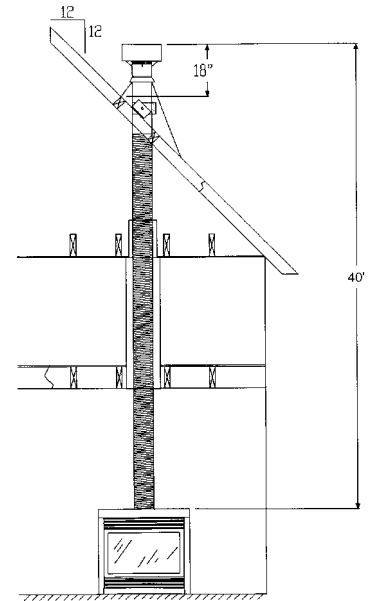



LIMITED LIFETIME WARRANTY

This Limited Lifetime Warranty applies only while the unit remains at the site of the original installation and only if the unit is installed inside the continental United States, Alaska, Hawaii, and Canada. The warranty applies only if the unit is installed and operated in accordance with the printed instructions and in compliance with applicable installation and building codes and good trade practices.

BASIC ONE YEAR WARRANTY

During the first year after installation, we will provide a replacement for any component part of your unit found to be defective in materials or workmanship, including labour costs. Repair work requires prior approval by Kingsman, labour costs are based on a predetermined rate schedule and any repair work must be done through an authorized Kingsman dealer.

LIMITED LIFETIME WARRANTY

The heat exchanger, combustion chamber and burner of every Kingsman product excluding the Outdoor Firepit are warranted against materials or workmanship during the period the product is owned by the original owner. The part to be replaced must be returned to our distributor in exchange for the replacement part. Any labor, material, freight and/or handling charges associated with any repair or replacement pursuant to this Limited Lifetime Warranty will not be covered by this warranty.

GENERAL TERMS

In lieu of providing a replacement part, we may, at our option, provide the distributor's component purchase price from us or a credit equal to the distributors component purchase price from us toward the purchase of any new unit which we distribute. If a credit is given in lieu of a replacement part, the rating plate from the unit being replaced must be submitted on a warranty claim, and the unit being replaced must be made available to our distributor for disposition.

In establishing the date of installation for any purpose, including determination of the starting date for the term of this Limited Lifetime Warranty, reasonable proof of the original installation date must be presented*, otherwise the effective date will be based upon the date of manufacture plus thirty (30) days.

We will not be responsible for and you, the user, will pay for: (a) damages caused by accident, abuse, negligence, misuse, riot, fire, flood, or Acts of God (b) damages caused by operating the unit where there is a corrosive atmosphere containing chlorine, fluorine, or any other damaging chemicals (other than in a normal residential environment) (c) damages caused by any unauthorized alteration or repair of the unit affecting its stability or performance (d) damages caused by improper matching or application of the unit or the unit's components (e) damages caused by failing to provide proper maintenance and service to the unit (f) any expenses incurred for erecting, disconnecting or dismantling the unit (g) parts or supplies used in connection with service or maintenance (h) damage repairs, inoperation or inefficiency resulting from faulty installation or application (i) electricity or fuel costs or any increase in electricity or fuel cost whatsoever including additional or unusual use of supplemental electric heat.

We shall not be liable for any incidental, consequential, or special damages or expenses in connection with any use or failure of this unit. We have not made and do not make any representation or warranty of fitness for a particular use or purpose, and there is no implied condition of fitness for a particular use or purpose. We make no express warranties except as stated in this Limited Lifetime Warranty. No one is authorized to change this Limited Lifetime Warranty or to create for us any other obligation or liability in connections with this unit. Any implied warranties shall last for one year after the original installation. Some states and provinces do not allow the exclusion or limitation of incidental or consequential damages or do not allow limitations on how long an implied warranty or condition lasts, so the above limitations or exclusions may not apply to you. The provisions of this limited warranty are in additions to and not a modification of or subtraction from any statutory warranties and other rights and remedies provided by law.

Save this certificate. It gives you specific legal rights, and you may also have other rights which may vary from state to state and province to province.

In the event your unit needs servicing, contact your dealer or contractor who installed or serviced your unit. When requesting service, please have the model and serial number from each unit readily available. If your dealer needs assistance, the distributor is available for support and we, in turn support the distributor's efforts.

Fill in the installation date and model and serial numbers of the unit in the space provided below and retain this limited warranty for your files.

Model No. _____ **Serial No.** _____ **Date installed** _____

Dealer or Contractor Name: _____

*To receive advantage of your warranty, you must retain the original records that can establish the installation date of your unit.