

CU 301

Ⓢ Installation and operating instructions

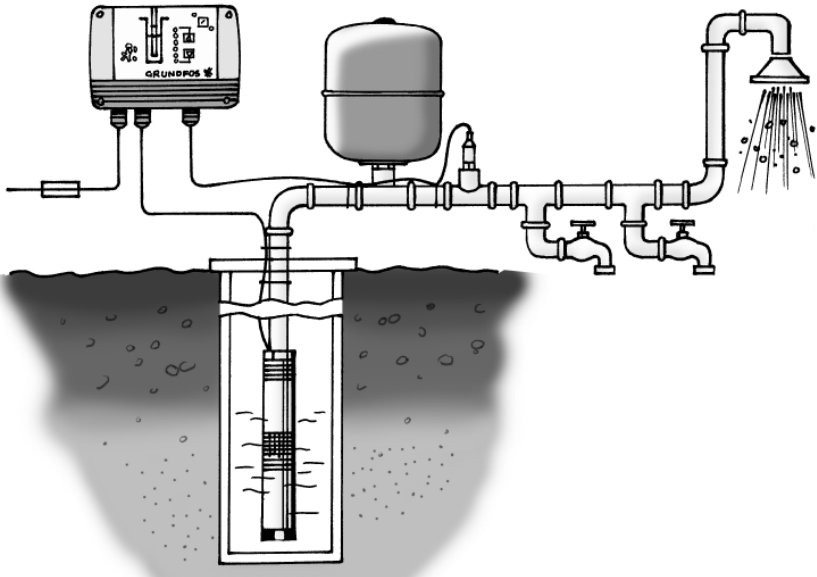

LIMITED WARRANTY

Products manufactured by GRUNDFOS PUMPS CORPORATION (Grundfos) are warranted to the original user only to be free of defects in material and workmanship for a period of 24 months from date of installation, but not more than 30 months from date of manufacture. Grundfos' liability under this warranty shall be limited to repairing or replacing at Grundfos' option, without charge, F.O.B. Grundfos' factory or authorized service station, any product of Grundfos' manufacture. Grundfos will not be liable for any costs of removal, installation, transportation, or any other charges which may arise in connection with a warranty claim. Products which are sold but not manufactured by Grundfos are subject to the warranty provided by the manufacturer of said products and not by Grundfos' warranty. Grundfos will not be liable for damage or wear to products caused by abnormal operating conditions, accident, abuse, misuse, unauthorized alteration or repair, or if the product was not installed in accordance with Grundfos' printed installation and operating instructions.

To obtain service under this warranty, the defective product must be returned to the distributor or dealer of Grundfos' products from which it was purchased together with proof of purchase and installation date, failure date, and supporting installation data. Unless otherwise provided, the distributor or dealer will contact Grundfos or an authorized service station for instructions. Any defective product to be returned to Grundfos or a service station must be sent freight prepaid; documentation supporting the warranty claim and/or a Return Material Authorization must be included if so instructed.

GRUNDFOS WILL NOT BE LIABLE FOR ANY INCIDENTAL OR CONSEQUENTIAL DAMAGES, LOSSES, OR EXPENSES ARISING FROM INSTALLATION, USE, OR ANY OTHER CAUSES. THERE ARE NO EXPRESS OR IMPLIED WARRANTIES, INCLUDING MERCHANTABILITY OR FITNESS FOR A PARTICULAR PURPOSE, WHICH EXTEND BEYOND THOSE WARRANTIES DESCRIBED OR REFERRED TO ABOVE.

Some jurisdictions do not allow the exclusion or limitation of incidental or consequential damages and some jurisdictions do not allow limit actions on how long implied warranties may last. Therefore, the above limitations or exclusions may not apply to you. This warranty gives you specific legal rights and you may also have other rights which vary from jurisdiction to jurisdiction.

CONTENTS

	Page
1. Constant-pressure control	5
1.1 Description	5
1.2 Function	5
1.3 System sizing	7
1.4 Positioning the pressure sensor	8
1.5 Precharge pressure setting	8
1.6 Pressure relief valve	8
2. Operating functions	9
2.1 On/Off button	9
2.2 Indication of pump operation	9
2.3 Pressure setting	9
2.4 Button locking	10
3. Alarm functions	10
3.1 Service alarm	10
3.2 Dry-running protection	11
4. Position of LEDs	12
5. CU 301 with R100	13
5.1 Menu OPERATION	15
5.1.1 Pressure setting	15
5.1.2 Operating mode	15
5.1.3 Alarm	15
5.2 Menu STATUS	16
5.2.1 Operating mode	16
5.2.2 Actual pressure	16
5.2.3 Speed	16
5.2.4 Temperature	16
5.2.5 Power input and power consumption	16
5.2.6 Operating hours and number of starts	17
5.3 Menu INSTALLATION	17
5.3.1 Sensor	17
5.3.2 Choice of sensor	17
5.3.3 Maximum pressure setting	17
5.3.4 Automatic restart	18
5.3.5 Dry-running stop	18
5.3.6 Maximum speed	18
5.3.7 Buttons on CU 301	18
5.3.8 Indication of pump operation	19
5.3.9 Number	19
6. Print	20
7. Troubleshooting	21
7.1 Service	21
8. Technical data	25
8.1 Electrical connection	26
8.1.1 Mains supply	27
8.1.2 Pump supply	27
8.1.3 Pressure sensor	27
9. Pressure sensor voltage chart	28

1. Constant-pressure control

The control unit CU 301 is for use only with Grundfos SQE pumps incorporating electronic power factor correction (PFC).

1.1 Description

The system maintains a constant pressure within the maximum pump performance in spite of a varying water consumption.

Fig. 1 shows an example of an installation with constant-pressure control.

The CU 301 is designed for wall mounting only.

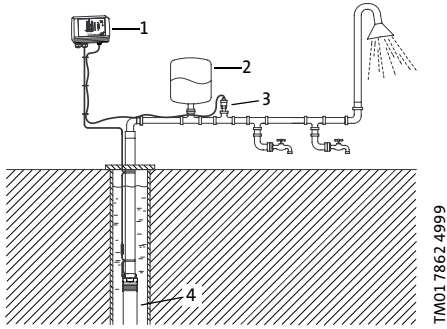

Fig. 1

Pos.	Description
1	CU 301
2	Diaphragm tank (2 gal.)
3	Pressure sensor
4	SQE pump

1.2 Function

The pressure is registered by means of the pressure sensor, which transmits a 4-20 mA signal to the CU 301. The CU 301 adjusts the pump performance accordingly to maintain constant pressure by changing the pump speed.

Mains borne signalling:

The communication between the CU 301 and the pump is via the power supply cable.

This communication principle is mains borne signalling (or power line communication). Using this principle means that no additional cables to the pump are required.

The communication of data is effected by means of a high-frequency signal transmitted to the power supply cable and led into the electronics unit by means of signal coils incorporated in the motor and the CU 301 respectively.

In situations where multiple CU 301 pump power cables are run parallel in wiring trays or conduit and less than 10-12 inches apart, the possibility for undesired communication between units exists. When this occurs, intermittent or continuous "No contact" is typically seen. Other unexpected errors may also be seen.

Refer to section 5.3.9 for further instructions.

Fig. 2 shows the principle of mains borne signalling between the CU 301 and the pump.

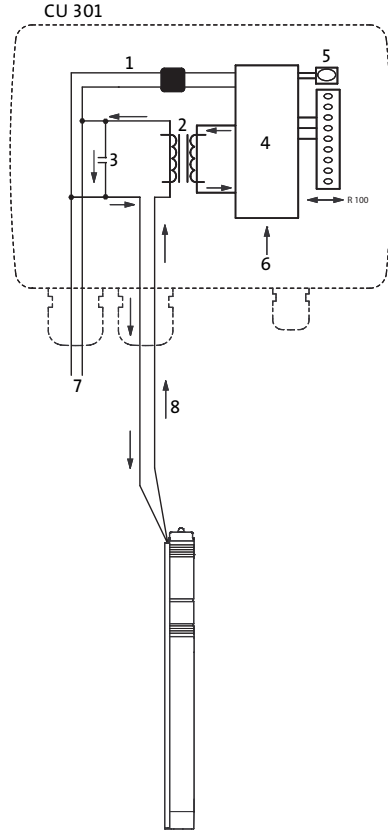

Fig. 2

Pos.	Description
1	Supply to the electronics
2	Signal coils
3	Capacitor
4	Electronics for the control of the communication
5	On/Off button
6	Sensor signal
7	Electricity supply
8	Communication signals

TM01 8495 1703

When does the pump start?

The pump starts as a consequence of

- a high flow or
- a low pressure or
- a combination of both.

To ensure that the pump is started when water is consumed, a flow detection is required. The flow is detected via pressure changes in the system. When water is consumed, the pressure will drop accordingly depending on the size of the diaphragm tank and the water flow:

- at a low flow, the pressure will drop slowly.
- at a high flow, the pressure will drop quickly.

See fig. 3.

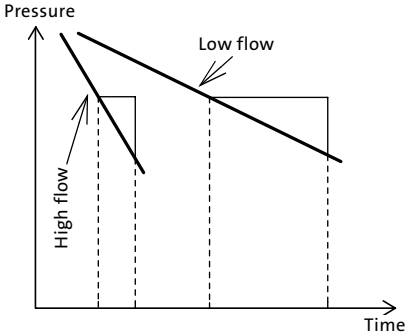

Fig. 3

Note: When the pressure is dropping 1.4 psi/s or faster, the pump will start immediately.

With a diaphragm tank of 2 gal., the pump will start at a flow rate of approx. 0.8 gpm.

Note: If a larger tank is used, the flow must be higher before the pump starts.

Consumption up to 0.8 gpm:

The pump will start when the pressure has dropped to 7 psi below the pressure setting.

The pump will run until the pressure is 7 psi above the pressure setting.

Flow detection:

During pump operation, i.e. when water is consumed, the CU 301 will adjust the pump speed to maintain a constant pressure. In order to stop the pump when no water is consumed, the CU 301 performs flow detection every 10 seconds.

The pump speed is reduced and pressure is read. A pressure drop indicates that water is being consumed and the pump speed is resumed, see fig. 4.

If the pump speed can be reduced without any pressure drop being registered, this indicates that no water is consumed. The diaphragm tank will be filled with water and the pump will be stopped.

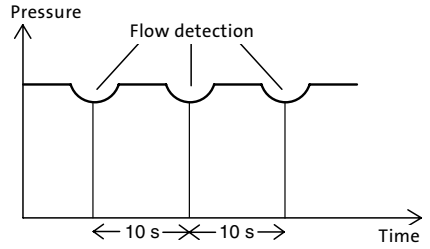

Fig. 4

System limits:

Even though the CU 301 is controlling the pressure within ± 3 psi, bigger pressure variations may occur in the system. If the consumption is suddenly changed, e.g. if a tap is opened, the water must start flowing before the pressure can be made constant again. Such dynamic variations depend on the pipework, but, typically, they will lie between 7 and 14 psi.

If the desired consumption is higher than the quantity the pump is able to deliver at the desired pressure, the pressure follows the pump curve as illustrated in the far right of fig. 5.

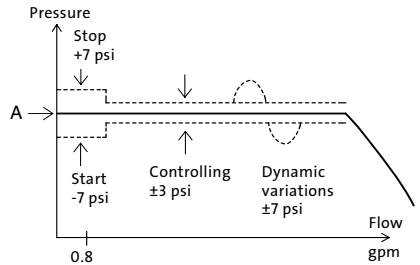

Fig. 5

A = Pressure setting

1.3 System sizing

To ensure the correct function of the system, it is important that the pump is of the right type.

During operation, the CU 301 controls the pump speed within the range from 3,000 rpm to 10,700 rpm, see fig. 6.

It is recommended to follow the guidelines below.

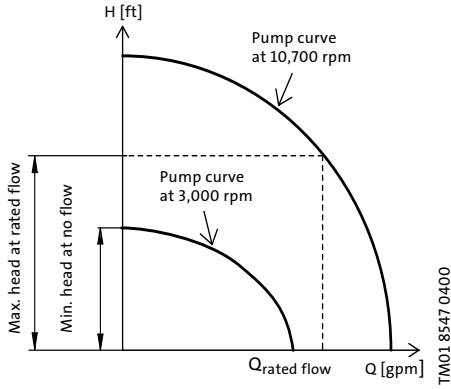

Fig. 6

The following must be fulfilled:

1. Min. head at no flow < static head + system pressure.
Comment: If this is not fulfilled, the pressure may exceed the pressure set on the CU 301.
2. Max. head at rated flow > dynamic head + system pressure.
Comment: If this is not fulfilled, the pressure may fall below the pressure set on the CU 301.

Max. head at rated flow and min. head at no flow can be found in the following table:

Pump type	Min. head at 0 gpm, 3,000 rpm	Max. head at rated flow, 10,700 rpm
	[feet]	[feet]
5 SQE - 90	12	86
5 SQE - 140	18	131
5 SQE - 180	22	177
5 SQE - 230	28	222
5 SQE - 270	34	270
5 SQE - 320	40	315
5 SQE - 360	46	360
5 SQE - 410	51	405
5 SQE - 450	57	450
10 SQE - 110	12	105
10 SQE - 160	17	164
10 SQE - 200	23	215
10 SQE - 240	29	267
10 SQE - 290	35	328
10 SQE - 330	40	390
15 SQE - 70	10	75
15 SQE - 110	15	123
15 SQE - 150	19	164
15 SQE - 180	24	205
15 SQE - 220	29	246
15 SQE - 250	33	287
15 SQE - 290	38	328
22 SQE - 40	5	36
22 SQE - 80	10	77
22 SQE - 120	14	117
22 SQE - 160	19	159
22 SQE - 190	23	200
22 SQE - 220	28	240
30 SQE - 40	6	33
30 SQE - 90	11	82
30 SQE - 130	17	126

1.4 Positioning the pressure sensor

Pressure losses often cause inconvenience to the user. The CU 301 keeps the pressure constant in the place where the pressure sensor is positioned, see fig. 7.

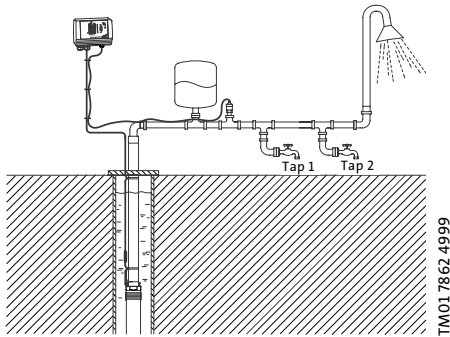

Fig. 7

In fig. 7, tap 1 is placed close to the pressure sensor. Therefore, the pressure will be kept nearly constant at tap 1, as the friction loss is small. At the shower and tap 2, the friction loss is greater. This, of course, depends on the piping.

Therefore, it is recommended that the pressure sensor be positioned as close to the places of consumption as possible.

1.5 Precharge pressure setting

The CU 301 is designed to work with a 2 gal. diaphragm tank.

The precharge pressure of the diaphragm tank must be set to 70% of the pressure setting in order to use the tank to the limit of its capacity. This is of course especially important when the tank volume is limited to 2 gal.

Use the values in the following table. Precharge pressure is measured with 0 psi in the pipeline:

Setting [psi]	Precharge pressure [psi]
40	28
50	35
60	42
70	49
80	56
90	63
100	70

Note: If the precharge pressure is higher than the pressure setting, the system will have difficulty controlling the pressure.

If the user wants to adjust the pressure without changing the precharge pressure of the diaphragm tank, the precharge pressure must be equal to the lowest pressure setting used. This means that the control will work but that the pressure fluctuations might increase.

1.6 Pressure relief valve

In order to provide protection against the possibility of an overpressurization, a pressure relieve valve should be installed down stream of the well head. The setpoint of the pressure relief valve should be at least 30 psi above the pressure setting, see section 2.3.

If a relief valve is installed, it is recommended that its discharge be plumbed into an appropriate drainage point.

2. Operating functions

2.1 On/Off button

Fig. 8 shows the On/Off button of the CU 301.

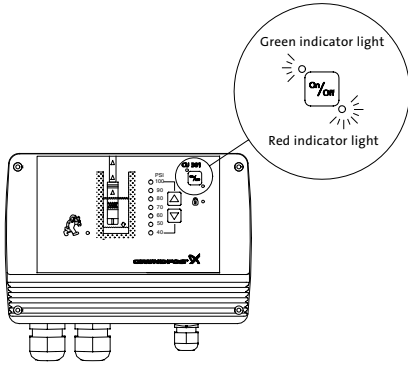

Fig. 8

The green and red indicator lights in the On/Off button indicate pump operating condition as follows:

Indication	Description
Green indicator light permanently on	The system is operational.
Green indicator light off	The system is not operational.
Red indicator light permanently on	Pump has been stopped by means of the On/Off button.*
Red indicator light flashing	The CU 301 is communicating with the R100.

* If the On/Off button has been used to stop the pump, this button must also be used for restarting. Any alarm indication can be reset by pressing the On/Off button.

If the On/Off button is pressed for more than 5 seconds, the pump is started, irrespective of any active fault/alarm indications and sensor signals.

When the On/Off button is released, the pump will stop, if the alarm still exists.

IMPORTANT

Setting this button to the OFF position DOES NOT remove power from the pump. Before servicing the pump, remove power at the service breaker.

2.2 Indication of pump operation

On the graphical illustration on the CU 301 front, the riser pipe shows running light when the pump is operating. When the pump is not operating, none of the indicator lights are on, see fig. 9.

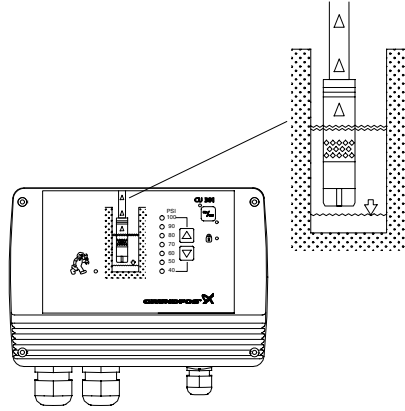

Fig. 9

The indication of pump operation can be changed by means of the R100.

Possible settings:

- “Running light” during pump operation (factory setting).
- “Constant light” during pump operation.

2.3 Pressure setting

The two arrow buttons on the CU 301 front are used for the pressure setting, see fig. 10.

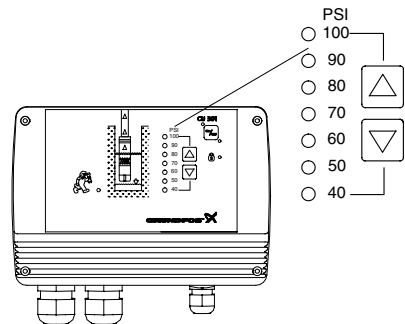

Fig. 10

TM02 4170 5101

TM02 4171 5101

Indication of pressure setting:

The system pressure set is indicated by a yellow indicator light, which is permanently on.
Setting range: 40-100 psi.

Arrow-up button:

When this button is pressed, the system pressure setting is increased in steps of 10 psi.

Arrow-down button:

When this button is pressed, the system pressure setting is decreased in steps of 10 psi.

2.4 Button locking

The buttons on the CU 301 can be locked/unlocked by pressing the two arrow buttons simultaneously for 5 seconds or via the R100 remote control.

Note: When the arrow buttons are used for locking, take care not to inadvertently change the pressure setting.

Use the following procedure:

1. Set the pressure one step up.
2. Press the arrow-down button as the first one when pressing the two buttons.

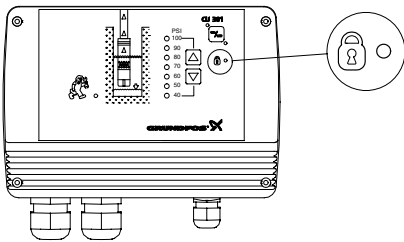

TM02 4172 5101

Fig. 11

When the buttons are locked, the indicator light is permanently on, see fig. 11.
For further information, see section 5.3.7 Buttons on CU 301.

3. Alarm functions

The CU 301 continuously receives operating data from the pump. The alarm functions indicated on the CU 301 front are described in the following sections.

3.1 Service alarm

If one or more factory-set alarm values are exceeded, the indicator light for service alarm is permanently on, see fig. 12.

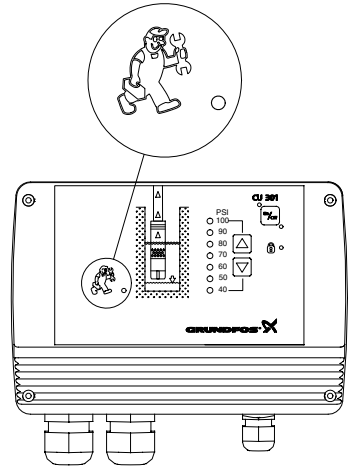

TM02 4173 5101

Fig. 12

Possible alarms:

- Sensor defective
- Overload
- Overtemperature
- Speed reduction
- Voltage alarm
- No contact to pump.

The possible alarms and how to identify them and make the relevant corrections are described in section 7.1 Service.

3.2 Dry-running protection

The purpose of the dry-running protection is to protect the pump in case of insufficient water flow.

The dry-running protection makes the conventional dry-running protection unnecessary.

No additional cables to the motor are required. The dry-running settings shown in section 8. *Technical data*, are built into the pump and automatically transmitted to the CU 301. These settings can be changed via the R100.

When air enters the pump together with water, the pump power decreases, and pressure drops, causing the motor to increase speed. If the power consumption falls below the dry run setting for an accumulated time of 5 seconds, and the motor speed is within 1,000 rpm of the maximum speed setting as defined in the section 5.3.6, the CU 301 stops the pump and declares a dry-running alarm.

When the motor is stopped, the dry-running indicator light is permanently on, see fig. 13, pos. A.

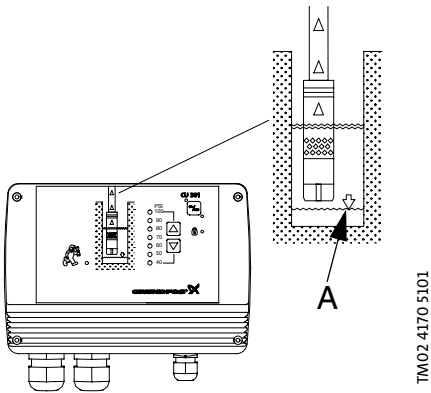

TM02 4170 5101

Fig. 13

Possible cause	Remedy
The pump performance is too high compared to the well yield.	Replace the pump with a smaller one.
	Reduce pump performance using the R100, display 5.3.6 <i>Maximum speed</i> .
Well screen is blocked.	Well service is required.

Restarting:

After 5 minutes (factory setting) or the period set by means of the R100, display 5.3.4 *Automatic restart*, the motor will restart automatically.

4. Position of LEDs

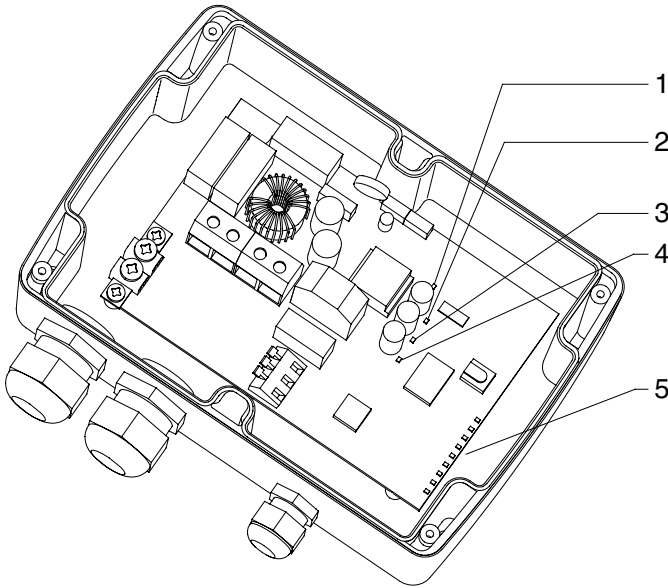

TM01 8537 I703

Fig. 14

Pos.	Indication	Description
1	+24 V overload	Permanent red light when the internal 24 VDC supply is overloaded.
2	+24 V	Permanent green light when the internal 24 VDC supply is OK.
3	+10 V	Permanent green light when the internal 10 VDC supply is OK.
4	+5 V	Permanent green light when the internal 5 VDC supply is OK.
5	9 indicator lights:	
	• Control indicator	• Flashing green light when the pump control is working correctly.
	• Min. speed	• Permanent yellow light when the pump is running at minimum speed, 3,000 rpm.
	• Max. speed	• Permanent yellow light when the pump is running at maximum speed, 10,700 rpm.
	• Sensor defective *)	• Permanent red light when the sensor signal is out of signal range.
	• Overload *)	• Permanent red light when the motor load exceeds the stop limit, see section 8. <i>Technical data</i> .
	• Overtemperature *)	• Permanent red light when the motor temperature exceeds the stop limit, see section 8. <i>Technical data</i> .
	• Speed reduction *)	• Permanent red light when the pump speed is reduced, see section 8. <i>Technical data</i> .
	• Voltage alarm *)	• Permanent red light when the supply voltage is out of range, see section 8. <i>Technical data</i> .
	• No contact to pump *)	• Permanent red light when communication between the CU 301 and the pump is impossible.

*) Press the On/Off button to reset the alarm indication.

5. CU 301 with R100

The remote control R100 can be used as a supplement for the installer and as an excellent troubleshooting tool. Grundfos highly recommends the use of one for diagnosing problems and accessing system information unavailable through other means. The R100 provides wireless communication with the CU 301.

Note: It is not necessary to use the R100 to operate the system. The R100 offers additional features.

The R100 communicates via infra-red light. During communication, there must be visual contact between the CU 301 and the R100. The best visual contact between the two units is obtained by pointing the R100 at the lower arrow button or by removing the front cover and pointing the R100 at the right side of the CU 301, see fig. 15.

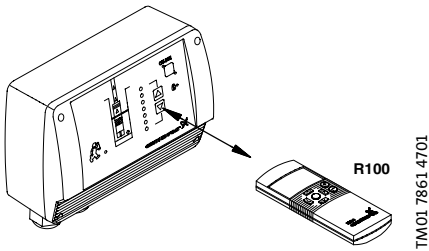

Fig. 15

The R100 offers possibilities of altering factory settings and reviewing operating status of the pump. When the communication between the R100 and CU 301 has been established, the red indicator light in the On/Off button will flash.

For general use of the R100, see the operating instructions included with it.

The menu structure for the R100 and CU 301 is divided into four parallel menus, each including a number of displays.

0. GENERAL, see operating instructions for the R100.

1. OPERATION

2. STATUS

3. INSTALLATION

Menu overview, see fig. 16, page 14.

Note: The number stated at each individual display in fig. 16 refers to the section in which the display is described.

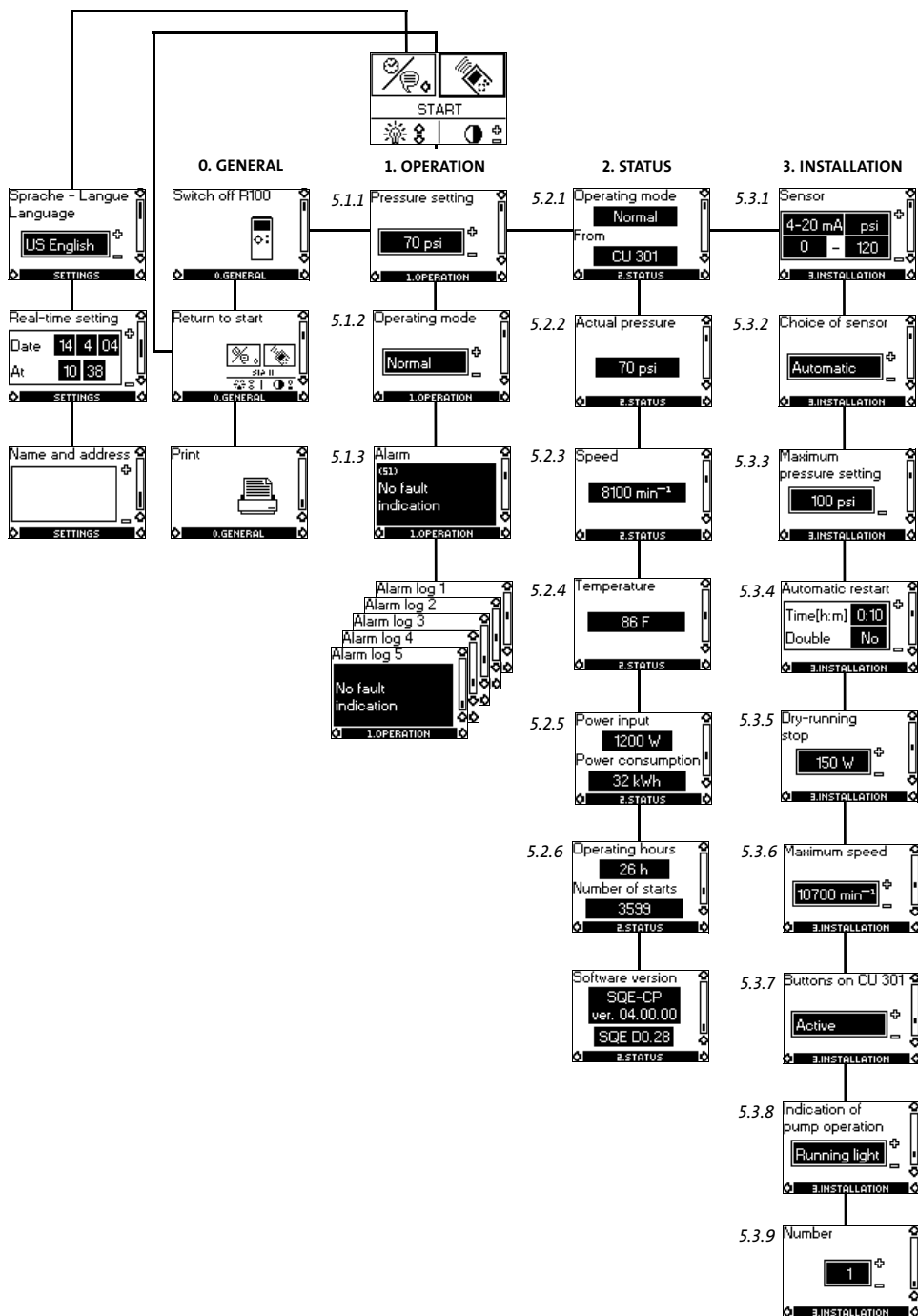

Fig. 16

5.1 Menu OPERATION

The OPERATION menu for the CU 301 offers the possibility of setting and reading operating parameters.

Factory settings are marked in **bold-faced type** under each individual display.

5.1.1 Pressure setting

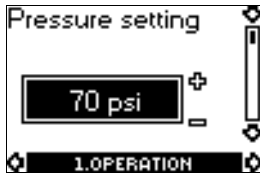

TM CU301_1_01 US

Set the required pressure.

Setting range:

- 40-100 psi (10 psi intervals), **50 psi**.

Relation to other displays:

The setting in display 5.1.1 *Pressure setting* is overridden by the "Max." and "Min." settings in the displays 5.1.2 *Operating mode* and 5.3.3 *Maximum pressure setting*.

5.1.2 Operating mode

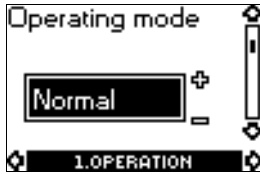

TM CU301_1_02 US

Select one of the following operating modes:

- **Max.**
Pump operation is set to maximum speed, irrespective of the pressure setting. The maximum speed is set in display 5.3.6 *Maximum speed* (factory setting: 10,700 min⁻¹).
- **Normal.**
Normal operating mode, i.e. pump operation is based on the pressure set in display 5.1.1 *Pressure setting*.
- **Min.**
Pump operation is set to minimum speed, 3,000 min⁻¹, irrespective of the pressure setting.
- **Stop.**
The pump is stopped.

If the On/Off button has been used to stop the pump, this button must also be used for restarting.

Relation to other displays:

The "Max." and "Min." settings override the pressure setting in display 5.1.1 *Pressure setting*.

5.1.3 Alarm

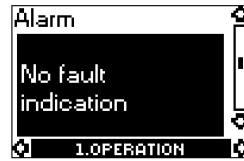

TM CU301_1_03 US

This display shows the current alarm status.

Possible alarms are described in the following table:

Alarm indication	Description
<i>No fault indication</i>	No alarms are registered by the CU 301.
<i>No contact to pump</i>	No communication between the CU 301 and the pump.*
<i>Overvoltage</i>	The supply voltage exceeds the limit value.
<i>Undervoltage</i>	The supply voltage is below the limit value.
<i>Dry running</i>	The dry-running protection of the pump has been activated.
<i>Overtemperature</i>	The motor temperature exceeds the limit value.
<i>Overload</i>	The current consumption of the motor exceeds the limit value.
<i>Sensor defective</i>	The sensor signal has fallen outside the measuring range set. The sensor signal of a 4-20 mA or 2-10 V sensor is below 2 mA or 1 V respectively.

* The pump will attempt to operate in on/off mode starting at 7 psi below pressure setting and stopping at 7 psi above pressure setting. The system must be reset every 250 stops.

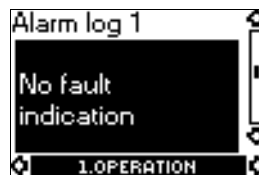

TM CU301_1_04 US

The R100 can retrieve the last five alarms that the CU 301 experienced. They are displayed in order of occurrence with "Alarm log 1" being the most recent.

5.2 Menu STATUS

The STATUS menu for the CU 301 provides operating data about pump/motor and sensor. It is not possible to change or set values in this menu.

When [OK] is pressed continuously in this display, the displayed value is being updated.

The measuring accuracy is stated in section 8. *Technical data*.

5.2.1 Operating mode

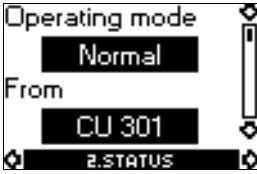

TM CU301_2_01 US

Possible operating modes:

- **Max.**
Pump operation has been set to maximum speed, e.g. 10,700 min⁻¹.
- **Normal.**
Normal operating mode, i.e. pump operation is based on the pressure set in display 5.1.1 *Pressure setting*.
- **Min.**
Pump operation has been set to minimum speed, 3,000 min⁻¹.
- **Stop.**
The pump has stopped.

The operating mode was selected from one of the following:

- **CU 301** (On/Off button on the CU 301).
- **R100**.
- **Sensor** (signals received via the sensor input).

5.2.2 Actual pressure

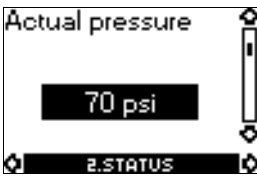

TM CU301_2_02 US

The actual system pressure measured by the pressure sensor.

Tolerance: ±1%.

5.2.3 Speed



TM CU301_2_03 US

The actual speed stated in min⁻¹ (rpm).
Tolerance: ±1%.

5.2.4 Temperature

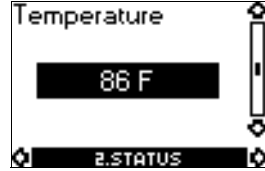

TM CU301_2_04 US

The actual temperature of the motor electronics stated in “C” or “F”, based on language selected in “settings”.

Tolerance: ±5%.

Relation to other displays:

To select “C”, choose the language “US English” in the settings menu.

5.2.5 Power input and power consumption

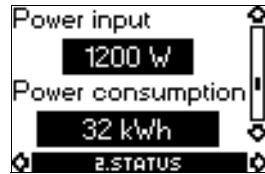

TM CU301_2_05 US

Power input:

The actual motor power from the electricity supply. The power input is displayed in W (watt).

Note: This value is used for the calculation of minimum power limit (dry-running stop).

Power consumption:

The accumulated motor power consumption in kWh. The value of power consumption is accumulated from the pump’s birth and it cannot be reset.

The value

- is stored in the motor electronics, and it is kept even if the CU 301 is replaced.
- is updated in the software every 2 minutes of continuous operation. The displayed value is updated every two hours.

Tolerance: ±5%.

5.2.6 Operating hours and number of starts



TM CU301_2_06 US

Operating hours:

The value of operating hours is accumulated from the pump's birth and it cannot be reset.

The value

- is stored in the motor electronics, and it is kept even if the CU 301 is replaced.
- is updated in the software every 2 minutes of continuous operation. The displayed value is updated every two hours.

Number of starts:

The value of number of starts is accumulated from the pump's birth and it cannot be reset.

The value is stored in the motor electronics, and it is kept even if the CU 301 is replaced.

5.3 Menu INSTALLATION

The INSTALLATION menu for the CU 301 offers the possibility of configuring the CU 301, pump/motor and sensor.

Factory settings are marked in bold-faced type under each individual display.

5.3.1 Sensor



TM CU301_3_04 US

Make the following settings according to sensor type:

- Sensor output signal: “-” (not active), *0-20 mA*, **4-20 mA**, *0-10 V*, **2-10 V**.
- Setting range unit: *bar*, **psi**.

Setting range, psi:

- Minimum value: **0**.
- Maximum value: *40-120 (40, 50, 60, 70 ... 120)*.

Setting range, bar:

- Minimum value: **0**.
- Maximum value: *2-6 (2, 2.5, 3, 3.5 ... 6.0)*.

Note: The pressure sensor used must measure the pressure in the actual measuring unit.

Relation to other displays:

The measuring unit appearing in display 5.2.2 *Actual pressure* will be identical to the measuring unit in the front cover.

Exception: If “Manual” is selected in display 5.3.2 *Choice of sensor*, the sensor can be set, irrespective of the front cover.

If changes are made in display 5.3.1 *Sensor*, the setting in display 5.3.2 *Choice of sensor* is changed to “Manual”.

If the original setting is resumed, it is necessary to change the setting in display 5.3.2 *Choice of sensor* from “Manual” to “Automatic”.

5.3.2 Choice of sensor

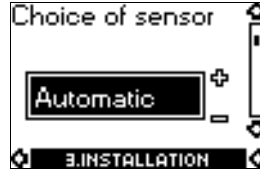

TM CU301_3_02 US

The following settings are available:

- **Automatic.**
- *Manual.*

Relation to other displays:

If, for some reason, the setting in this display has changed to “Manual” and this is changed to “Automatic”, the setting of the displays 5.3.1 *Sensor* and 5.3.3 *Maximum pressure setting* will change to the factory setting.

5.3.3 Maximum pressure setting



TM CU301_3_03 US

The setting of this display overrules the possibility of using the arrow button on the CU 301 front to increase the pressure to a setting above the “Maximum pressure setting”.

The following settings are available:

- *40-100 psi*, in steps of 10 psi.

Relation to other displays:

The setting of this display overrules the possibility of using the display 5.1.1 *Pressure setting* to increase the pressure to a setting above the “Maximum pressure setting”.

If the setting is changed from 100 psi, the setting in display 5.3.2 *Choice of sensor* changes from “Automatic” to “Manual”.

5.3.4 Automatic restart

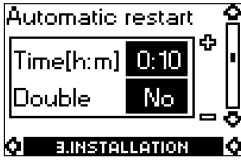

TM CU301_3_04 US

Set the automatic restart time from stop, caused by an alarm, to restart attempt.

The following settings are available:

Time:

- 0:05.
- “-” (not active).
- 1, 2, ... 30 m (1 min. intervals),
30, 45, 1 h, ... 2 h (15 min. intervals),
2 h 30 m, 3 h, ... 4 h (30 min. intervals).

Double:

- Yes.
- No.

When “Yes” is selected, the restart time set will be doubled automatically for every 10 motor stops caused by an alarm. The time is doubled up to a stop time of 4 hours. After 10 hours of operation without an alarm, the restart time is automatically set to:

- the time set in the “Time” field or
- 5 min. (factory setting) if no setting was made in the “Time” field.

5.3.5 Dry-running stop



TM CU301_3_05 US

The dry-running stop value is factory-set.

The factory setting depends on the power rating of the motor.

The following settings are default:

- Motor type A 1/3 - 1/2 hp, dry-running stop = **300 W**.
- Motor type B 1/2 - 3/4 hp, dry-running stop = **680 W**.
- Motor type C 1 - 1 1/2 hp, dry-running stop = **800 W**.

When the dry-running protection is to be active, the minimum value of the pump power input must be set in this display.

Setting range: 0-2500 W (10 W intervals).

Relation to other displays:

The actual pump power input can be read in display 5.2.5 *Power input and power consumption*.

If the maximum pump speed has been reduced in display 5.3.6 *Maximum speed*, the dry-running stop value must be changed.

5.3.6 Maximum speed



TM CU301_3_06 US

Set the maximum speed.

Setting range: 3,000-10,700 min⁻¹ (100 min⁻¹ intervals).

Dry-running stop at reduced maximum pump speed:

If the maximum pump speed has been reduced, the dry-running stop value in display 5.3.5 *Dry-running stop* must be changed.

Calculating the minimum power limit:

Note: The calculated value is used in display

5.3.5 Dry-running stop.

Note: If the pump is worn, a renewed calculation of the minimum power limit may be required.

Step	Action
1	Start the pump against closed discharge valve.
2	Read the power input (P ₁) in display 5.2.5 <i>Power input and power consumption</i> .
3	Calculate the minimum power limit as follows: Power limit [W] = P ₁ · 0.9.

5.3.7 Buttons on CU 301



TM CU301_3_07 US

The buttons on the CU 301 can be set to:

- Active.
- Not active.

5.3.8 Indication of pump operation



TM CU301_3_08 US

The following settings are available:

- *Running light.*
- *Constant light.*

5.3.9 Number



TM CU301_3_09 US

Allocate a number to the CU 301 and the pump connected. The CU 301 and the pump must have the same number.

The CU 301 control unit communicates with the SQE pumps via the pump power cable to turn the pumps on and off, set motor speed and monitor pump status.

The technique used for performing this communication impresses a high frequency data signal on the pump power cable that is picked off by internal pump electronics and then decoded into command instructions. This is the reason for assigning unique numbers to each CU 301 in a multiple unit installation. The unique number serves as a communication address between each CU 301 control unit/motor pair.

In situations where multiple CU 301 pump power cables are run parallel in wiring trays or conduit and less than 10-12 inches apart, the possibility for undesired communication between units exists. When this occurs, intermittent or continuous “No contact” is typically seen. Other unexpected errors may also be seen.

There are two approaches available to eliminating the possibility of this occurring:

1. Physical separation of cables:
Maintain a minimum distance of 10-12 inches between pump power cables, and never place more than one cable in a conduit.
2. Use shielded cable:
The use of shielded cable prevents cross communication between parallel cables and allows sharing of conduit and cable trays. Tie the cable shield to earth only at the CU 301 control unit.

Suitable cables:

<u>Manf.</u>	<u>Part#</u>	<u>Gage</u>
Anixter	2A-1403S	14
Anixter	2A-1203S	12
Anixter	2A-1003S	10

Anixter (1-800-321-1486)

In addition, Grundfos recommends applying power to only one CU 301 unit/motor at a time while programming the CU 301 number with the R100. This will prevent the possibility of two pumps hearing the same number assignment command.

6. Print

The actual data in the R100 can be printed on a Hewlett-Packard printer type HP82240B.

Navigate the R100 to the print menu and point the R100 at the IR sensor of the printer and press [OK].

The following information will be printed:

<u>R100</u>	
<u>Status report</u>	
Product type: CU 301	
Software version:	
SQE-CP ver. 03.00.00	
SQE D0.30	
<u>Settings</u>	
<u>General:</u>	
Pressure setting	60 psi
Operating mode	Normal
Max. pres. set.	(psi)
	100
Auto. rest. time	0:01
Auto. rest. db.	No
Dry-run stop	150 W
Max. speed(speed)	10,700
Buttons on CU 301	Active
Operat. indicat. Run.	
Number	1
<u>Sensor</u>	
Type	4-20 mA
Unit	psi
Choice	Manual
	<u>Min. Max.</u>
Range	0 120
<u>Actual values</u>	
	<u>Value</u>
Operating mode	Stop
From	CU 301
Act. pressure	64 psi
Temperature	74 F
Speed	0 min ⁻¹
Power input	20 W
Power consump.	10 kWh
Operat. hours	18 h
Num. of starts	397
<u>Alarm</u>	
No fault	
indication	
Date	: 15.5.02
At	: 13:24

7. Troubleshooting



Before starting any work on the CU 301, make sure that the electricity supply has been switched off and that it cannot be accidentally switched on.

7.1 Service

The CU 301 continuously receives operating data from the pump. In case of an alarm, the service indicator light is permanently on, see fig. 17.

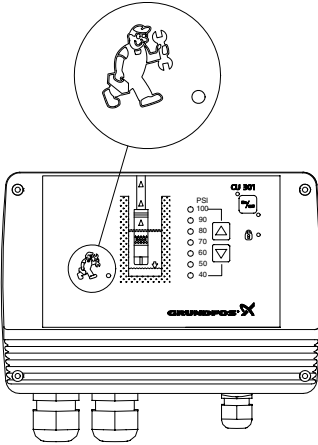

Fig. 17

The service indicator light will be permanently on if one of the following alarm situations occurs:

- Sensor defective
- Overload
- Overtemperature
- Speed reduction
- Voltage alarm
- No contact to pump.

To identify the cause of the service alarm, it is necessary to remove the front cover from the CU 301 or use the R100. Fit the front cover as shown in fig. 18 to avoid disconnecting the multi-core cable.

TM02 4173 5101

A number of LEDs are mounted on the supply board inside the CU 301, see section 4. *Position of LEDs.*
Fig. 18 shows the LEDs and the alarm texts on the supply board.

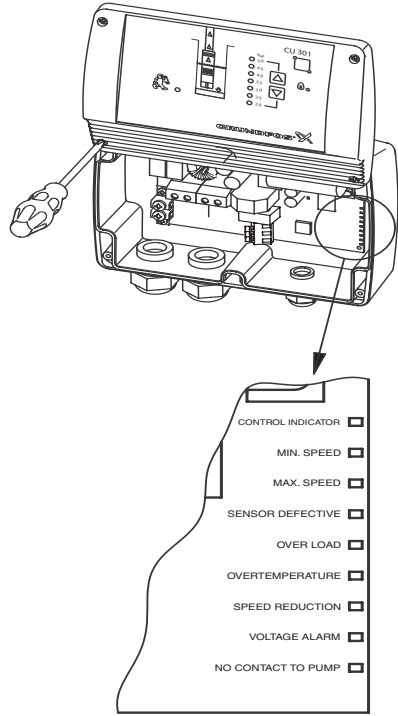

Fig. 18

TM01 8435 1703

Fault	Possible cause	Remedy
1. No light in the front cover.	a) The ribbon cable connection is loose or defective.	<ul style="list-style-type: none"> • Is the control indicator LED flashing? If not, the CU 301 is defective. • Check that the ribbon cable connection is secure.
2. The pump does not start. The green indicator light in the On/Off button is on. No alarm is indicated.	a) The CU 301, the pressure sensor or the pump is defective.	<p>Check</p> <ul style="list-style-type: none"> • that the control indicator LED is flashing. If not, the CU 301 is defective. • that the system pressure is 7 psi below the pressure setting. If so, the pump is supposed to start. Open a tap to be sure. If the pump starts, the system is probably OK. The system pressure can be read on the pressure gauge. • Refer to fault 13 to troubleshoot the pressure sensor. <p>If the pump has not started yet, proceed as follows:</p> <ul style="list-style-type: none"> • Press the On/Off button for 5 seconds. If the pump starts, the CU 301 or the sensor may be defective. <p>Note: The pressure is not controlled and may rise to a high level.</p>
3. The pressure is not constant.	<p>a) The pump is not of the correct type or the precharge pressure of the diaphragm tank is incorrect.</p> <hr/> <p>b) No contact between SQE pump and CU 301 control unit.</p>	<p>Check</p> <ul style="list-style-type: none"> • that the LED for Max. speed or Min. speed is on. If so, this indicates that the pump has reached a limit. See section 1.3 <i>System sizing</i>. Replace the pump, if necessary. • the precharge pressure of the diaphragm tank. Note: Remember to stop and drain the system before the pressure is checked. • Make sure the diaphragm tank is the 2 gal. size. • whether the sensor is positioned far away from the tap. If so, the pressure variations may be caused by friction losses, see section 1.4 <i>Positioning the pressure sensor</i>. <hr/> <p>Check that the LED for “No contact to pump” is on. If so, go to fault no. 14.</p>
4. The pump is running continuously.	a) The pump cannot deliver the set pressure. The CU 301 or the sensor is defective.	<ul style="list-style-type: none"> • Try to lower the pressure setting, see section 1.3 <i>System sizing</i>. Note that the pump may run for about 15 to 20 seconds before it stops. • Check that the control indicator LED is flashing. • Check that the pipe end of the sensor is not blocked. If so, remove the blockage. • Try to stop the pump by means of the On/Off button. If this is not possible, the CU 301 is defective. Replace the CU 301. • Refer to fault 13 to troubleshoot the pressure sensor.

(continued on the following page)

5. The CU 301 indicates "No contact to pump".	<p>a) The motor is not an MSE 3.</p> <hr/> <p>b) The pump cable is longer than 650 feet.</p> <hr/> <p>c) Cable breakage.</p> <hr/> <p>d) Cross communication with adjacent CU 301.</p> <hr/> <p>e) The CU 301 communication part is defective.</p> <hr/> <p>f) The MSE 3 motor communication part is defective.</p>	<p>If the pump has already worked satisfactorily with a CU 301 or a CU 300, the motor can be expected to be an MSE 3. There is no technical way of determining the motor type. The only way is to read the nameplate engraved in the motor sleeve.</p> <hr/> <p>Reduce the length of the pump cable.</p> <hr/> <p>Switch off the mains supply to the CU 301. Switch on the mains supply again. The pump is now connected direct to the mains supply without interference from the CU 301. Does the motor start? Yes: The cable is OK. Go to point d). No: Switch off the mains supply again. Remove cable and cable plug from the motor and ohm out cable including plug. Is the cable OK? Yes: The motor is defective. Replace the motor. No: Replace the cable.</p> <hr/> <p>If another CU 301 is installed:</p> <ul style="list-style-type: none"> • Insure each unit has a unique number assigned. See section 5.3.9 <i>Number</i>. • If pump cables run parallel to each other, physically separate them by 12-14 inches or rewire using shielded cable. <hr/> <p>Are the three CU 301 supply board LEDs in pos. 2, 3 and 4 on and is the control indicator LED flashing? See section 4. <i>Position of LEDs</i>. Yes:</p> <ul style="list-style-type: none"> • The mains supply is OK. • Assign the system a new number. <p>If this does not work, the CU 301 or the motor communication part is defective. Replace the CU 301 and give the new system a number between 1 and 64 in order to obtain correspondence between the numbering of the SQE pump and the CU 301. Note: Two systems on the same mains supply must not have the same number! Is the LED "No contact to pump" of the new CU 301 also on? Yes: The CU 301 is OK. Go to point f). No: The CU 301 which was removed is defective.</p> <hr/> <p>As a consequence of the above-mentioned checks, replace the MSE 3 motor.</p>
6. Even AFTER replacement, the CU 301 indicates "No contact to pump".	<p>a) Numbering of SQE pump and CU 301 is different.</p>	<p>If an SQE/CU 301 system has been given a number, this number is stored in both the SQE and CU 301. A new CU 301 or SQE may not have a number corresponding to the number stored in the previous unit. Therefore, "No contact to pump" is indicated even if there is no fault. Give a new system the number between 1 and 64 in order to obtain correspondence between the numbering of the SQE pump and the CU 301. Note: Two systems on the same mains supply must not have the same number!</p>
7. The CU 301 indicates "Overvoltage" or "Undervoltage".	<p>a) The supply voltage is unstable or outside the voltage range specified for the installed motor type.</p>	<p>Check - possibly over a period of time - that the supply voltage is according to the values below. Motor type A $\frac{1}{3}$ - $\frac{1}{2}$ hp = 190 - 320 V. Motor type B $\frac{1}{2}$ - $\frac{3}{4}$ hp = 190 - 320 V. Motor type C 1 - $1\frac{1}{2}$ hp = 210 - 320 V. Note: As the voltage is detected at the motor, allow for the voltage drop in the pump cable.</p>

(continued on the following page)

8. The CU 301 indicates "Dry running".	If the power consumption is lower than the dry-running stop setting and the motor speed is within 1,000 rpm of programmed maximum speed, for an accumulated period of 5 seconds, the pump will be stopped.
a) The pump performance is too high for the well yield.	Replace the pump with a smaller pump or reduce the pump performance, by lowering maximum speed, or reducing set pressure.
b) The well screen is blocked.	Check the well capacity and restore water supply to the well.
c) The dry-running stop setting is incorrect.	Check and correct the setting, see section 5.3.5 <i>Dry-running stop</i> .
9. The CU 301 indicates "Speed reduction" and "Undervoltage".	Speed reduction is activated so as to maintain a reduced performance. When the supply voltage falls so low that it can no longer supply the necessary current to maintain 3,000 min ⁻¹ , the pump will be stopped.
a) The supply voltage is unstable or lower than the voltage range specified for the installed motor type.	Restore correct supply voltage.
b) The pump is not of the correct type.	Install correct pump type.
c) The voltage drop in the pump cable is too great.	Replace the pump cable with lower gauge wires.
10. The CU 301 indicates "Speed reduction" and "Overload".	Speed reduction is activated so as to maintain a reduced performance.
a) The pump is worn or blocked.	The pump must be serviced.
b) The pump is too large for the installed motor.	Replace pump or motor.
11. The CU 301 indicates "Overtemperature".	The temperature sensor in the motor is sensing a temperature above the values stated in 8. <i>Technical data</i> , Factory settings.
a) Insufficient cooling of the motor.	Restore correct cooling of the motor. The flow velocity past the motor should be at least 0.5 ft/s.
12. The CU 301 indicates "Overload".	The pump must be serviced.
a) The pump is worn or blocked.	The pump must be serviced.
b) The pump is too large for the installed motor.	Replace pump or motor.
13. The CU 301 indicates "Sensor defective".	<p>a) The pressure sensor is defective.</p> <p>Check that the sensor is wired correctly. Check that the R100 setting of the sensor is correct, see section 5.3.1. If the sensor type is 4-20 mA, measure the DC voltage across the sensor input terminals. If the DC voltage measured at the sensor input terminals is not between 2 and 10 V the sensor or wiring is defective. Refer to section 9., page 28, for additional troubleshooting assistance. Replace defective parts. Are the LED "Sensor defective" and the LED, pos. 1, on? See section 4. <i>Position of LEDs</i>. Yes: The total load of 24 VDC from terminal 5 is above 100 mA. Disconnect the sensor in order to determine if it is defective. Replace defective sensor. No: The load is OK, but the CU 301 sensor input may be defective.</p>

(continued on the following page)

14. The pump is operating on/off. a) No communication.

Check that the LED "No contact to pump" is on. If so, the control unit CU 301 starts and stops the pump, based on the sensor signal only. The CU 301 has to be reset every 250 stops. Refer to fault no. 5 for remedy.

8. Technical data

Supply voltage

1 x 100-240 V -10%/+6%, 50/60 Hz, PE.

Power consumption

5 W.

Back-up fuse

Maximum 16 A.

Current consumption

Maximum 130 mA.

Mains borne signalling

Frequency shift keying (FSK).
(132.45 kHz \pm 0.6 kHz).

Enclosure class

IP 55.

Maximum length between CU 301 and pump

650 feet.

Ambient temperature

- During operation: -22 to +113°F (-30 to +45°C)
(must not be exposed to direct sunlight).
- During storage: -22 to +140°F (-30 to +60°C).

Weight

4.5 lb.

Relative air humidity

Maximum 95%.

Materials

The CU 301 box is made of black PPO.

EMC (electromagnetic compatibility)

According to EN 55 014 and EN 55 014-2.

Dimensional sketch

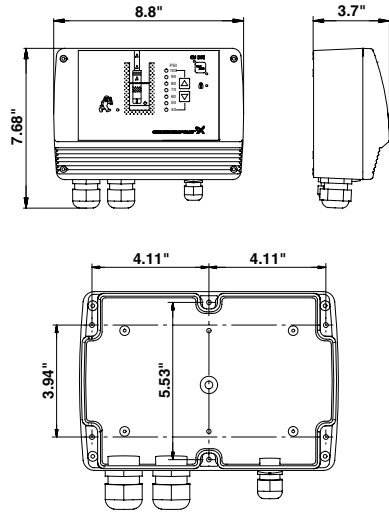

Fig. 19

Sensor input

Voltage signal:

0-10 VDC/2-10 VDC, $R_i = 11 \text{ k}\Omega$

Tolerance: $\pm 3\%$ at maximum voltage signal.

#22 ga. Screened cable is recommended.

Maximum cable length: 1640 ft (500 m).

Current signal:

DC 0-20 mA/4-20 mA, $R_i = 500 \Omega$.

Tolerance: $\pm 3\%$ at maximum current signal.

#22 ga. Screened cable is recommended.

Maximum cable length: 1640 ft (500 m).

External sensor

TM02 4174 2603

Factory settings

Alarm	200-240 V motors			100-115 V motors
	SQ/SQE/SQE-NE 03A and 05A models	SQ/SQE/SQE-NE 05B and 07B models	SQ/SQE/SQE-NE 1.0C and 1.5C models	All models
Sensor defective	4-20 mA (the value is stored in the CU 301)			
Overload	5 A	8 A	11 A	11 A
Overtemperature	Stop limit: 149°F (65°C)	Stop limit: 167°F (75°C)	Stop limit: 185°F (85°C)	Stop limit: 185°F (85°C)
	Restart: 131°F (55°C)	Restart: 149°F (65°C)	Restart: 167°F (75°C)	Restart: 167°F (75°C)
Speed reduction	In connection with undervoltage or overload			
Overvoltage *)	320 VAC	320 VAC	320 VAC	185 VAC
Undervoltage	Speed reduction: 190 V	Speed reduction: 190 V	Speed reduction: 210 V	Speed reduction: 90 V
	Stop limit: 150 V	Stop limit: 150 V	Stop limit: 150 V	Stop limit: 75 V
Dry running	300 W	680 W	800 W	300 W

*) 200-240 V motors: Operation is guaranteed up to 280 VAC.

100-115 V motors: Operation is guaranteed up to 150 VAC.

In order to avoid unnecessary stops, the overvoltage stop limit is as stated.

Accuracy of R100 readings

Operation

Display	Accuracy
5.2.2 Actual pressure	±1.4 psi
5.2.3 Speed	±1%
5.2.4 Temperature	±5%
5.2.5 Power input and power consumption	±5%

Sensor

The sensor signal accuracy depends on the sensor type. See the sensor specifications in question.

8.1 Electrical connection

The electrical connection should be carried out by an authorized electrician.



Never make any connections on the CU 301 terminal block unless the electricity supply has been switched off. The CU 301 must be connected in accordance with the local rules and regulations.

IMPORTANT

The On/Off button on the CU 301 must not be used as a safety switch when installing and servicing the pump.

Mains disconnecter must be provided by the installer. "Raintight or wet location hubs that comply with the requirements in the standard for Fittings for Conduit and Outlet Boxes, UL514B, are to be used. Suitable devices for CU 301 are rated with enclosure type 3, 3R, 3S, 4, 4X, 6 or 6P".

The supply voltage and frequency are marked on the nameplate. Make sure that the CU 301 is suitable for the electricity supply on which it will be used.

If the CU 301 is connected to an electric installation where a Ground Fault Circuit Interrupter (GFCI) is used as an additional protection, this device must trip out when earth fault currents with DC content (pulsating DC) occur.

The CU 301 has two terminal blocks:

- Terminals 1 to 4.
- Terminals 5 to 7.

Furthermore, the CU 301 is equipped with two screw terminals for the protective earth leads (PE).

Always use copper conductors approved for 60/75°C (140/167°F).

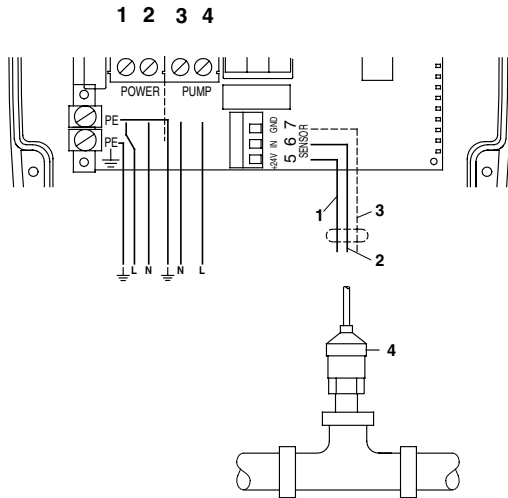

Fig. 20

Legend:

Pos.	Description
1	Standard pressure sensor +24 VDC, brown lead, terminal 5
2	Standard pressure sensor Input signal, black lead, terminal 6
3	Standard pressure sensor Braid, terminal 7
4	Standard pressure sensor

8.1.1 Mains supply

POWER, terminals 1, 2 and PE:

Connect terminals 1 and 2 to the phase and neutral leads of the mains supply. Each terminal can be connected to any of the two leads. Torque: 15 lbf-in.

Connect the PE terminal to the green/yellow earth lead. Torque: 9.0 - 15.3 lbf-in. Each PE terminal must be connected to an earth lead of its own.

Maximum wire size of the leads to be connected is 10 AWG.

Circuit breaker: Maximum 16 A.

Note: The leads of the mains supply must not be connected to terminals 3 and 4 (PUMP).

8.1.2 Pump supply

PUMP, terminals 3, 4 and PE:

Connect terminals 3 and 4 to the phase and neutral leads of the pump. Each terminal can be connected to any of the two leads. Torque: 15 lbf-in.

Connect the PE terminal to the green/yellow earth lead. Torque: 9.0 - 15.3 lbf-in. Each PE terminal must be connected to an earth lead of its own.

Maximum wire size of the leads to be connected is 10 AWG.

In situations where multiple CU 301 pump power cables are run parallel in wiring trays or conduit and less than 10-12 inches apart, the possibility for undesired communication between units exists. When this occurs, intermittent or continuous “No contact” is typically seen. Other unexpected errors may also be seen. Refer to section 5.3.9 *Number* for further instructions.

8.1.3 Pressure sensor

SENSOR, terminals 5, 6 and 7:

Terminals 5, 6 and 7 (SENSOR) are used for the pressure sensor.

Sensor signals:

The sensor to be connected must provide signals within one of the following ranges:

- 0-10 V
- 2-10 V
- 0-20 mA
- 4-20 mA - factory default.

Changeover between current and voltage signals is carried out by means of the R100.

Important!

The total load of terminal 5 (+24 VDC) must not exceed 100 mA.

9. Pressure sensor voltage chart

Voltage to pressure chart for CU 301 pressure sensors. Measure DC voltage between “SENSOR IN” and “SENSOR GND”. Voltages less than 2 or greater than 10 indicate an incorrectly wired or a faulty sensor.

DC voltage	psi	DC voltage	psi	DC voltage	psi
1.9	0.0	4.5	40.5	7.1	81.0
2.0	0.7	4.6	41.2	7.2	81.7
2.0	1.5	4.6	42.0	7.2	82.5
2.1	2.2	4.7	42.7	7.2	83.2
2.1	3.0	4.7	43.5	7.3	84.0
2.2	3.7	4.8	44.2	7.3	84.7
2.2	4.5	4.8	45.0	7.4	85.5
2.3	5.2	4.8	45.7	7.4	86.2
2.3	6.0	4.9	46.5	7.5	87.0
2.4	6.7	4.9	47.2	7.5	87.7
2.4	7.5	5.0	48.0	7.6	88.5
2.4	8.2	5.0	48.7	7.6	89.2
2.5	9.0	5.1	49.5	7.7	90.0
2.5	9.7	5.1	50.2	7.7	90.7
2.6	10.5	5.2	51.0	7.8	91.5
2.6	11.3	5.2	51.7	7.8	92.2
2.7	12.0	5.3	52.5	7.9	93.0
2.7	12.8	5.3	53.2	7.9	93.7
2.8	13.5	5.4	54.0	8.0	94.5
2.8	14.3	5.4	54.7	8.0	95.2
2.9	15.0	5.5	55.5	8.1	96.0
2.9	15.7	5.5	56.2	8.1	96.7
3.0	16.5	5.6	57.0	8.2	97.5
3.0	17.2	5.6	57.7	8.2	98.2
3.1	18.0	5.7	58.5	8.3	99.0
3.1	18.7	5.7	59.2	8.3	99.7
3.2	19.5	5.8	60.0	8.4	100.5
3.2	20.2	5.8	60.7	8.4	101.3
3.3	21.0	5.9	61.5	8.4	102.0
3.3	21.7	5.9	62.2	8.5	102.8
3.4	22.5	6.0	63.0	8.5	103.5
3.4	23.2	6.0	63.7	8.6	104.3
3.5	24.0	6.0	64.5	8.6	105.0
3.5	24.7	6.1	65.2	8.7	105.8
3.6	25.5	6.1	66.0	8.7	106.5
3.6	26.2	6.2	66.7	8.8	107.3
3.6	27.0	6.2	67.5	8.8	108.0
3.7	27.7	6.3	68.2	8.9	108.8
3.7	28.5	6.3	69.0	8.9	109.5
3.8	29.2	6.4	69.7	9.0	110.3
3.8	30.0	6.4	70.5	9.0	111.0
3.9	30.7	6.5	71.2	9.1	111.8
3.9	31.5	6.5	72.0	9.1	112.5
4.0	32.2	6.6	72.7	9.2	113.3
4.0	33.0	6.6	73.5	9.2	114.0
4.1	33.7	6.7	74.2	9.3	114.8
4.1	34.5	6.7	75.0	9.3	115.5
4.2	35.2	6.8	75.7	9.4	116.3
4.2	36.0	6.8	76.5	9.4	117.0
4.3	36.7	6.9	77.2	9.5	117.8
4.3	37.5	6.9	78.0	9.5	118.5
4.4	38.2	7.0	78.7	9.6	119.3
4.4	39.0	7.0	79.5	9.6	120.0
4.5	39.7	7.1	80.2		

Subject to alterations.

NOTES

NOTES

U.S.A.

GRUNDFOS Pumps Corporation
17100 West 118th Terrace
Olathe, Kansas 66061
Phone: +1-913-227-3400
Telefax: +1-913-227-3500

Canada

GRUNDFOS Canada Inc.
2941 Brighton Road
Oakville, Ontario
L6H 6C9
Phone: +1-905 829 9533
Telefax: +1-905 829 9512

Mexico

Bombas GRUNDFOS de Mexico
S.A. de C.V.
Boulevard TLC No. 15
Parque Industrial Stiva Aerop-
uerto
Apodaca, N.L. 66600
Mexico
Phone: +52-81-8144 4000
Telefax: +52-81-8144 4010

L-SP-TL-019 Rev. 10/04	US
PRINTED IN THE USA	