



GB-01 SURFACE MOUNT BOX



GB01CS-01T-12080

1. PARTS IDENTIFICATION

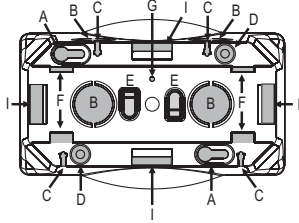

- A - Holes for box insertion or screw fixing
- B - Knock-out holes for conduits
- C - Box feet pins for workbench mounting
- D - Screw fixing holes
- E - Box feet for workbench mounting
- F - DIN rail latches
- G - Reinforcement screw hole
- I - Square conduit inlets

1.2. Opening the box

Insert the tip of a screwdriver in the side square hole and turn it until it clicks to remove the front cover and the side switch covers. Then remove the internal side screws to remove the internal frame.

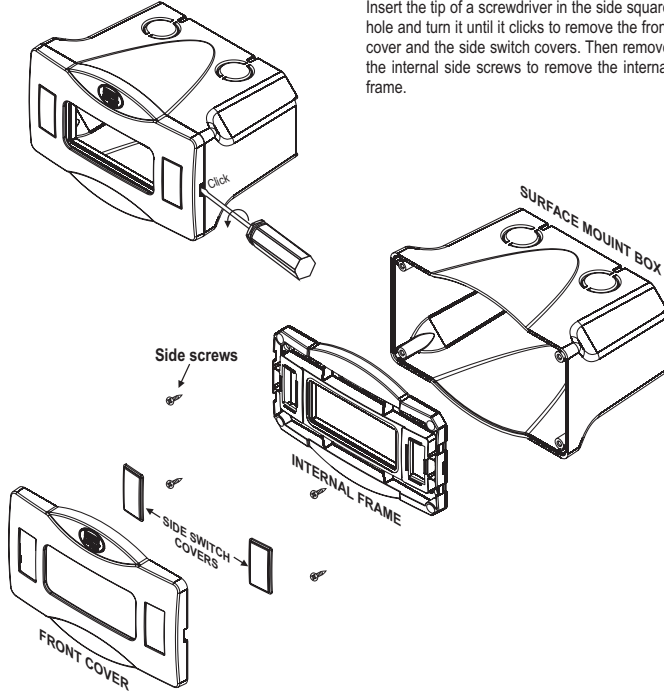

2. BOX MOUNTING OPTIONS

2.1. DIN rail mounting

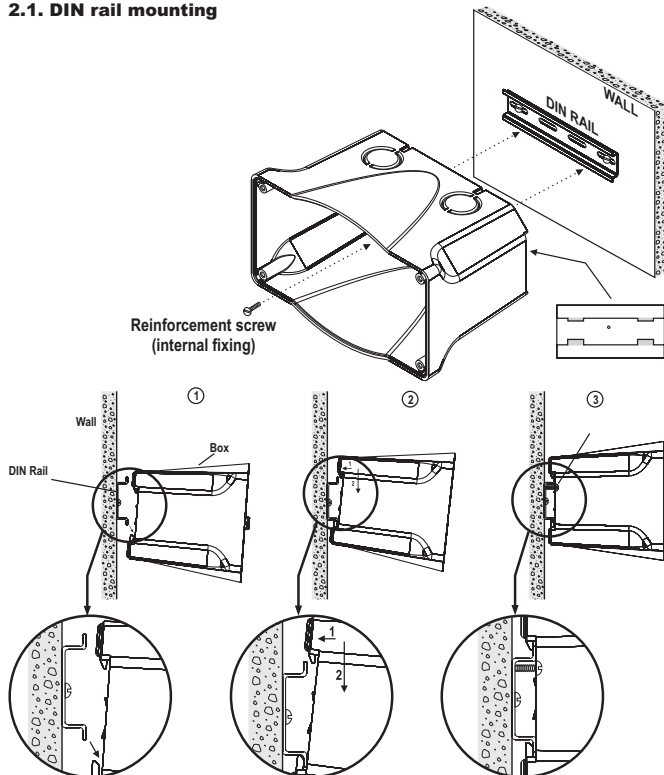

2.2. Surface mounting

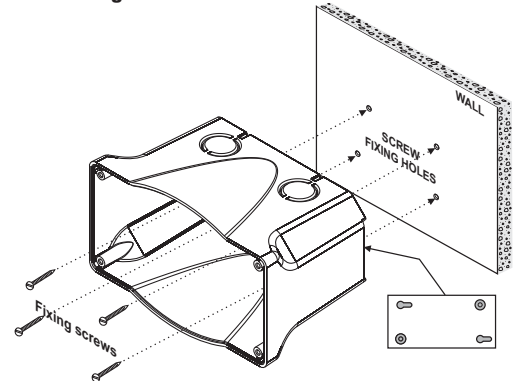

NOTE: The box can also be mounted with the conduit hole side down.

3. WIRING THE CABLES

Wire the cables according to your needs. The surface mount box provides conduit inlets on the top (which can be turned down), on the rear side and also provides inlets for square conduits.

ATTENTION
Electrical shock/short circuit hazard. Check if the power source is disconnected before installing.

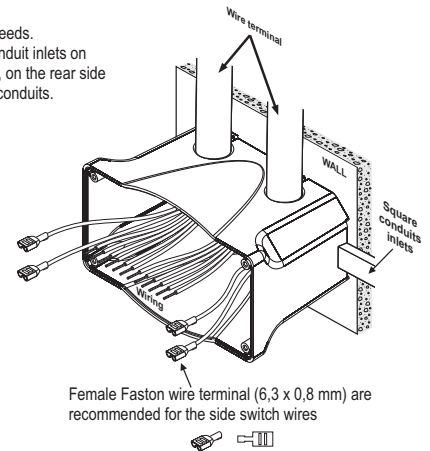

IMPORTANT

- According to the instructions described in the IEC60364 standard:
- 1: Over voltage protection must be installed in the power supply.
 - 2: Sensor and computer data cabling may run together but not in the same conduits where power supply and load driving cables are running.
 - 3: Surge suppress (RC filters) must be installed in parallel with the loads to enhance relay life.

4. INSTALLING THE DEVICE INSIDE THE SURFACE MOUNT BOX

4.1. Assembling device and internal frame

Insert the device and side switches (if any) through the internal frame front side. Insert the side locks for the device through the rear side as shown in the illustration below.

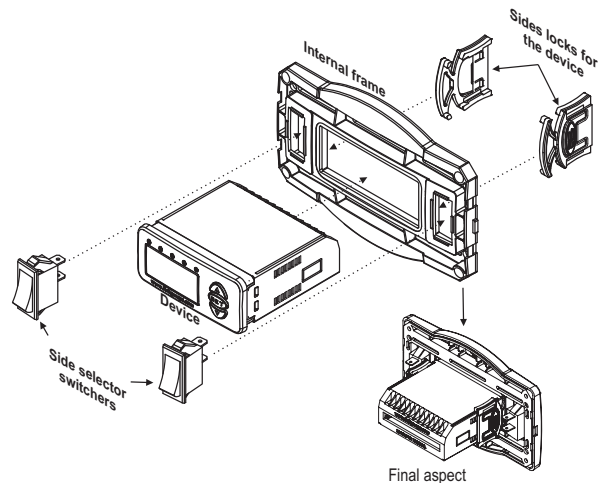

NOTE: Side selector switches - 15A/250VAC single pole switch

4.2. Electric connections

Connect the electrical wiring of the device according to the connection diagram shown in the corresponding device guide.

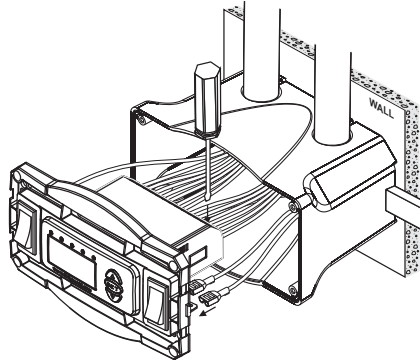

4.3. Fixing the Internal frame and installing the front cover

Replace the internal frame inside the box and fix it with the side screws. Then install the front cover.
Note: If no side switches are installed, replace the side switch covers to cover the switch holes. Momentarily fix the side switch covers with an adhesive tape in the front cover external side until the front cover is fixed in the box, then remove the adhesive tapes.

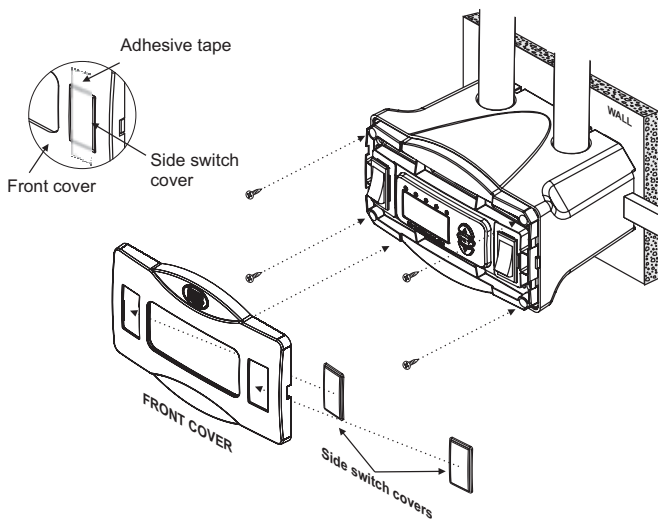

4.4. Final aspect

The assembly work result must be as shown in the illustration below. See the corresponding figure for both mountings: with/without side switches.

Installation set assembled with side switches Box model GB-01C

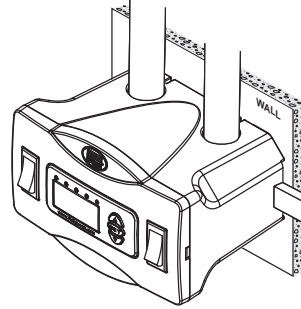

Installation set assembled without side switches

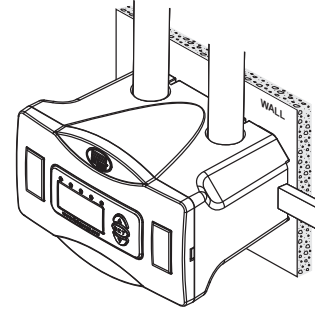

5. WORKBENCH INSTALLATION

The box can be installed in workbenches or over any proper surface by using the box feet. Knock-out the box feet from the rear box side and fix them in their places according to the illustration below.

