

# 40000 SERIES



## FLANGED BALL VALVES



[www.americanvalve.com](http://www.americanvalve.com)



Industry-Leading Innovation

**American Valve** commits itself to consistently fulfilling our customers' needs and expectations by supplying products that are built with confidence and quality. This commitment is accomplished by achieving the following objectives:

- **American Valve** ensures continuous reliability and quality by using well-trained personnel and through the implementation of a quality system that meets international standard ISO 9001.
- **American Valve** develops and maintains professional working relationships in all aspects of its business and builds customer confidence by consistently delivering quality products in a timely manner.
- **American Valve** will continue to pursue a pioneering role in the industry by supplying products which focus on the customer's current and future needs and expectations.

*Our goal at American Valve is to be fully responsive to the customers' needs, and to operate within a system which ensures our ability to provide our customers with quality products today and for the future.*

## 4000 SERIES

### Green Building Benefits



#### ENERGY SAVINGS

Zero Leakage: Valuable hot water or steam in hydronic heating system is not lost

- Maintains consistent temperature throughout system
- Huge savings of expensive oil/gas needed to regenerate loss



#### WATER QUALITY

- PFA\* fused ball
- No VOC's
- Lead Free

PFA\* fused ball resists build up thru valve port, maintaining reliable flow rate and efficient heat transfer.

\*PFA is an ingredient commonly branded as Teflon®.

# MODEL 4000

## Cast Iron Flanged End Ball Valve



Part	Material
1 Body	Cast Iron/A126 Class B
2 Ball	Cast Iron/PFA* Fused
3 Stem	Stainless Steel
4 Gland Plate	Steel
5 Handle	Steel
6 Handle Bracket	Ductile Iron
7 Packing Follower	Stainless Steel
8 Stem Indicator	Steel
9 Handle Bracket Spacer	Steel
10 Stem Stud	Carbon Steel
11 Gland Stud	Carbon Steel
12 Body Stud	Carbon Steel
13 Body Nut	Carbon Steel
14 Handle Bracket Bolt	Carbon Steel
15 Packing	PTFE (Chevron)
16 Body Gasket	PTFE
17 Seat Ring	RPTFE 15% GF
18 Back Seat O-Ring	PTFE
19 Handle Grip	Vinyl Rubber Foam
20 Body Cap	Cast Iron/A126 Class B

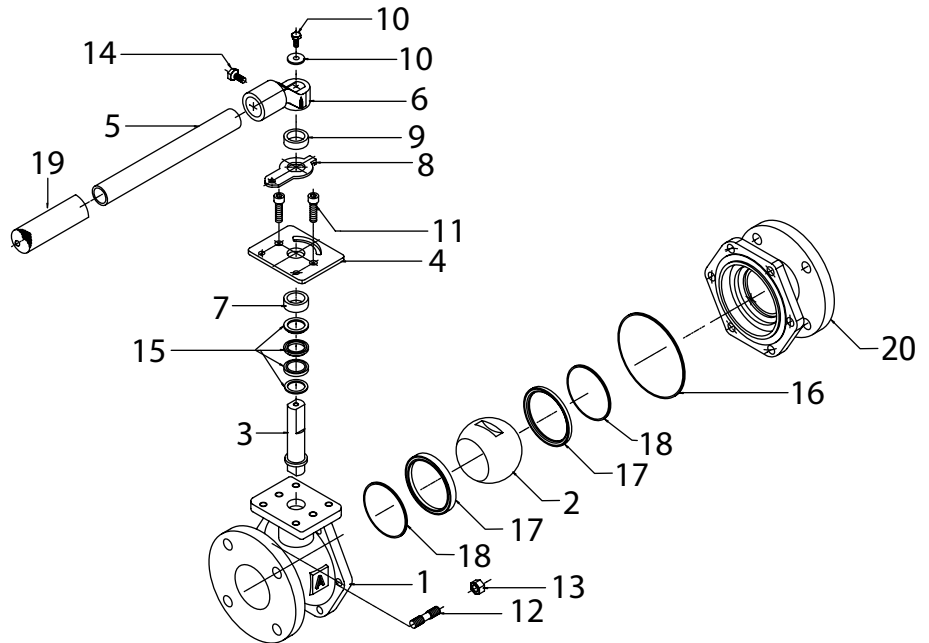

DIMENSIONS:	½	¾	1	1 ½	2	2 ½	3	4	6	8	10
A Face to Face	4.25"	4.625"	5"	6.5"	7"	7.5"	8"	9"	10.5"	11.5"	13"
B Center of Port to Top	4.25"	4.25"	4.75"	6"	6.5"	7.5"	8.25"	9"	12"	12.25"	13.5"
C Flange Diameter	3.5"	3.875"	4.25"	5"	6"	7"	7.5"	9"	11"	13.5"	16"
D Center of Valve to Handle End	11.875"	11.875"	11.875"	12.25"	12.5"	14"	14"	16"	30.5"	30.5"	33.625"
E Port Diameter	0.5"	0.75"	1"	1.5"	2"	2.5"	3"	4"	6"	6"	7.875"
Bolt Holes	4	4	4	4	4	4	4	8	8	8	12
Weight lbs.	6	7	10	17	24	43	50	77	149	190	309
CV	26	50	100	260	500	750	1245	2500	5470	4150	6700

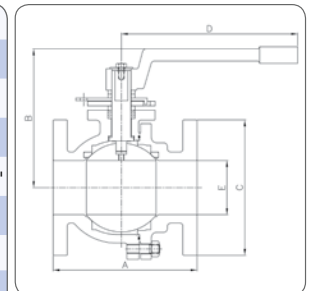

- A126 Class B Cast Iron Body
- PFA\* Fused Solid Ball
- Blow-out Proof Stainless Steel Stem
- Reinforced PTFE Seats
- Face to Face and Flanged Dimensions conform to ANSI Standard B16.10 which exactly match end to end dimensions of all cast iron gate valves and plug valves
- Lockable in Full Open or Closed Positions
- Mounting Pad for Easy Actuation
- Adjustable Length/Removable Handles to fit into areas of limited space
- Full Port through 6"

### SPECIFICATIONS:

MSS SP-72  
ANSI B16.10  
FED. SPEC. WW-V-35  
AWWA C507-99 Proof of Design Test

### RATING:

125 psi WSP  
200 psi WOG  
353° F

This patented Cast Iron Ball Valve has been engineered to replace any IBBM Gate Valve, All Iron Gate Valve, or Plug Valve.

\*PFA is an ingredient commonly branded as Teflon®.

### SAMPLE SPECIFICATION:

Ball valves shall be of the floating-ball design capable of providing bi-directional, tight shutoff in accordance with MSS SP-72. The valves shall be rated at 125# WSP/200# WOG. Bodies shall be of cast iron per ASTM A126 Class B, With ANSI Class 125 flat-face flanges. The interior and exterior of the body shall be epoxy-coated. The ball shall be PFA infused cast iron, with a stainless steel blowout-proof stem. The seats and body seals shall be PTFE. The stem seal shall be PTFE, externally adjustable chevron type. Valves shall be equipped with locking handles as standard. If service conditions require, valves may be equipped with 2" square operating nuts, manual gear operators, or pneumatic, electric, or hydraulic actuators. Valves shall be the Series 4000 as manufactured by American Valve, Inc. or as approved by the engineer.

# MODEL 4000D

## Ductile Iron Flanged End Ball Valve



Part	Material
1 Body	Ductile Iron/A536
2 Ball	Stainless Steel/PFA* Fused
3 Stem	Stainless Steel
4 Gland Plate	Steel
5 Handle	Steel
6 Handle Bracket	Ductile Iron
7 Packing Follower	Stainless Steel
8 Stem Indicator	Steel
9 Handle Bracket Spacer	Steel
10 Stem Stud	Carbon Steel
11 Gland Stud	Carbon Steel
12 Body Stud	Carbon Steel
13 Body Nut	Carbon Steel
14 Handle Bracket Bolt	Carbon Steel
15 Packing	PTFE (Chevron)
16 Body Gasket	PTFE
17 Seat Ring	RPTFE 15% GF
18 Back Seat O-Ring	PTFE
19 Handle Grip	Vinyl Rubber Foam
20 Body Cap	Ductile Iron/A536

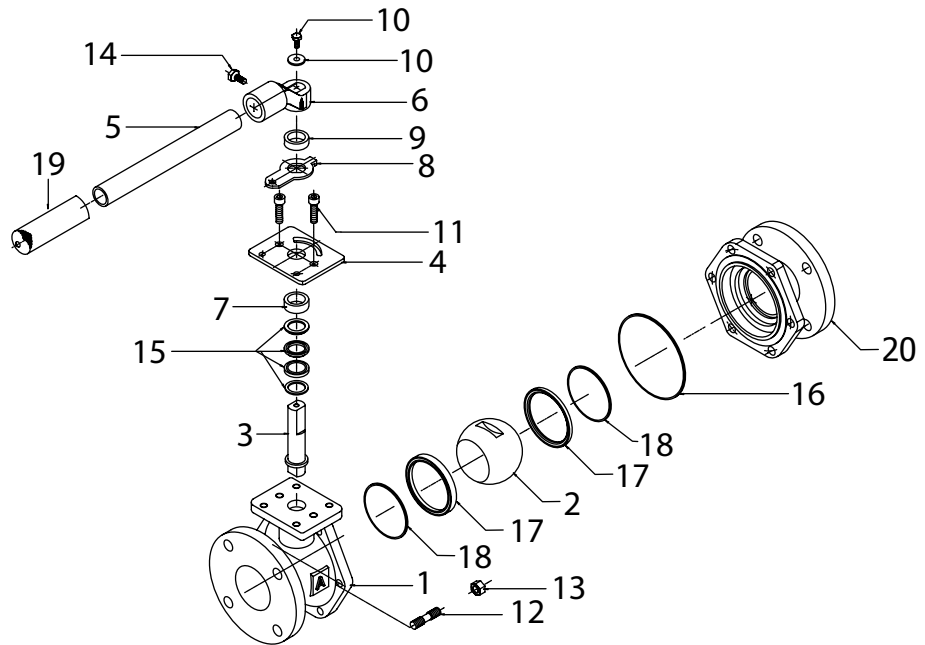

DIMENSIONS:	2	2 ½	3	4	6	8	10
A Face to Face	7"	7.5"	8"	9"	10.5"	11.5"	13"
B Center of Port to Top	6.5"	7.5"	8.25"	9"	12"	12.25"	13.5"
C Flange Diameter	6"	7"	7.5"	9"	11"	13.5"	16"
D Center of Valve to Handle End	12.25"	14"	14"	16"	30.5"	30.5"	33.625"
E Port Diameter	2"	2.5"	3"	4"	6"	6"	7.875"
Bolt Holes	4	4	4	8	8	8	12
Weight lbs.	25	42	55	78	149	194	318
CV	500	750	1245	2500	5470	4150	6700

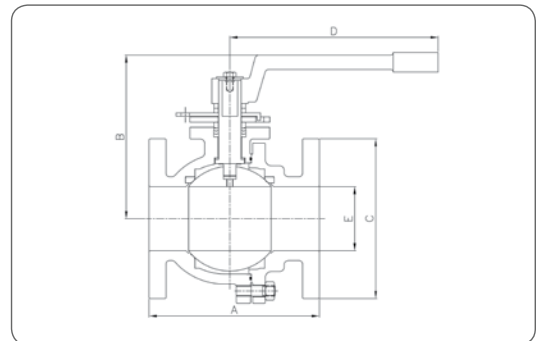

- A536 Grade 65-45-12 Ductile Iron Body
- PFA\* Fused Solid Stainless Steel Ball
- Blow-out Proof Stainless Steel Stem
- Reinforced PTFE Seats
- Face to Face and Flanged Dimensions conform to ANSI Standard B16.10 which exactly match end to end dimensions of carbon steel ball valves, ductile iron gate valves, and plug valves
- Lockable in Full Open or Closed Positions
- Mounting Pad for Easy Actuation
- Adjustable Length/Removable Handles to fit into areas of limited space
- Full Port through 6"

### SPECIFICATIONS:

MSS SP-72  
ANSI B16.5 Raised Face  
FED. SPEC. WW-V-35  
AWWA C507-99 Proof of Design Test

### RATING:

150 psi WSP  
300 psi WOG  
366° F

This Ductile Iron Ball Valve has been engineered to replace any plug valve, carbon steel ball valve, or gate valve.

\*PFA is an ingredient commonly branded as Teflon®.

### SAMPLE SPECIFICATION:

Ball valves shall be of the floating-ball design capable of providing bi-directional, tight shutoff in accordance with MSS SP-72. The valves shall be rated at 150# WSP/300# WOG. Bodies shall be ductile iron per ASTM A536, With ANSI Class 150 raised-face flanges. The interior and exterior of the body shall be epoxy-coated. The ball shall be PFA infused stainless steel, with a stainless steel blowout-proof stem. The seats and body seals shall be PTFE. The stem seal shall be PTFE, externally adjustable chevron type. Valves shall be equipped with locking handles as standard. If service conditions require, valves may be equipped with 2" square operating nuts, manual gear operators, or pneumatic, electric, or hydraulic actuators. Valves shall be the Series 4000D as manufactured by American Valve, Inc. or as approved by the engineer.

# MODEL 4001

## Stainless Steel Flanged End Ball Valve



Part	Material
1 Body	ASTM A351-CF8M
2 Ball	ASTM A351-CF8M/PFA* Fused
3 Stem	A276-316
4 Gland Plate	AISI 304
5 Handle	ASTM A312 Schd 40 GR 304
6 Handle Bracket	ASTM A351 CF8
7 Packing Follower	A276-316
8 Stem Indicator	AISI 304
9 Handle Bracket Spacer	AISI304
10 Stem Stud	0193-B8
11 Gland Stud	0193-B8
12 Body Stud	0193-B8
13 Body Nut	0193-B8
14 Handle Bracket Bolt	0193-B8
15 Packing	PTFE (Chevron)
16 Body Gasket	PTFE
17 Seat Ring	RPTFE 15% GF
18 Back Seat O-Ring	PTFE
19 Handle Grip	Vinyl Rubber Foam
20 Body Cap	ASTM A351-CF8M

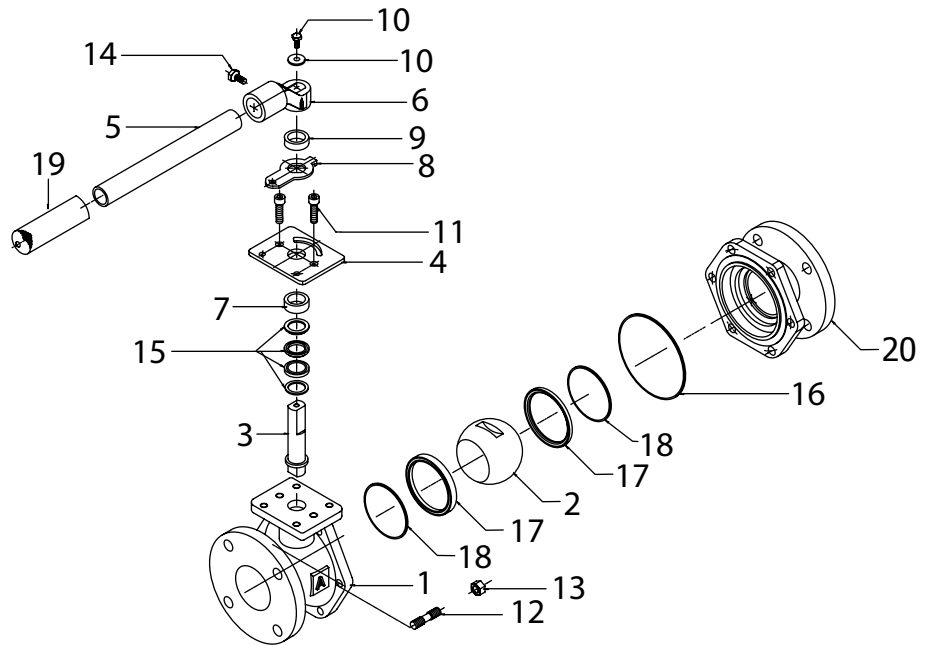

DIMENSIONS:	1 ½	2	2 ½	3	4	6
A Face to Face	6.5"	7"	7.5"	8"	9"	10.5"
B Center of Port to Top	6"	6.5"	7.5"	8.25"	9"	12"
C Flange Diameter	5"	6"	7"	7.5"	9"	11"
D Center of Valve to Handle End	12.25"	12.25"	14"	14"	16"	30.5"
E Port Diameter	1.5"	2"	2.5"	3"	4"	6"
Bolt Holes	4	4	4	4	8	8
Weight lbs.	16	22	38	49	73	145
CV	260	500	750	1245	2500	5470

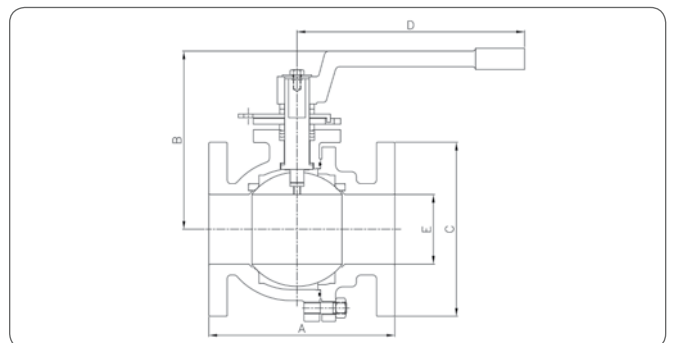

- Cast 316 Stainless Steel (CF8M)
- PFA\* Fused Solid Stainless Steel Ball
- Blow-out Proof Stainless Steel Stem
- Reinforced PTFE Seats
- Full Opening for Unrestricted Flow
- Lockable in Full Open or Closed Positions
- API 607 Fire Safe Design
- Mounting Pad for Easy Actuation
- Adjustable Length/Removable Handles to fit into areas of limited space

### SPECIFICATIONS:

MSS SP-72  
ANSI B16.5 Raised Face  
FED. SPEC. WW-V-35  
AWWA C507-99 Proof of Design Test

### RATING:

150 psi WSP  
300 psi WOG  
366° F

This patented Stainless Steel Ball Valve with PFA\* fused ball has been Engineered to more effectively resist corrosion and prolong valve life.

*\*PFA is an ingredient commonly branded as Teflon®.*

### SAMPLE SPECIFICATION:

Ball valves shall be full port and of the floating-ball design capable of providing bi-directional, tight shutoff in accordance with MSS SP-72. The valves shall be rated at 150# WSP/300# WOG. Bodies shall be stainless steel per ASTM A351-CF8M, With ANSI Class 150 raised-face flanges. The ball shall be PFA infused stainless steel, with a 316 stainless steel blowout-proof stem. The seats and body seals shall be PTFE. The stem seal shall be PTFE, externally adjustable chevron type. Valves shall be equipped with locking handles as standard. If service conditions require, valves may be equipped with 2" square operating nuts, manual gear operators, or pneumatic, electric, or hydraulic actuators. Valves shall be the Series 4001 as manufactured by American Valve, Inc. or as approved by the engineer.

## 4000 Series

vs. Gate, Plug, and Butterfly Valves



### Advantages of 4000 Series

vs. Gate Valves

Quarter turn provides instant shutoff

Full unobstructed opening provides superior flow rate

Easy to open and close, no cheater bar required

Positive shutoff- Exceeds Class VI

No bronze seat rings, bronze disc rings or bronze stems to wear out

Lighter than gate valves, making installation and handling easier

Handle shows whether open or closed

Ball wipes clean during opening and closing

No bronze parts enables use in all-iron gate valve applications.

Compact design fits into areas of limited space.

Throttling is permitted. Open and shut are not the only working positions.

Low profile design enables easier storage and shipping.

Can be locked in either open or closed position.

PFA\* fused ball resists corrosion, in a wider range of applications

Zero wear rate in the open position

Unique packaging prevents damage during shipping and facilities storage

Easy and inexpensive to rebuild/repair

*\*PFA is an ingredient commonly branded as Teflon®.*

### Advantages of 4000 Series

vs. Butterfly Valves

No disc in waterway to create turbulence

Same ANSI flanged dimensions as gate valves for easier retrofit

PTFE seats, not Buna N or EPDM

More suitable for steam, petroleum, and corrosive applications

Main seating surface does not face upstream pressure in open position

Full opening provides superior flow characteristics

PTFE packing instead of O-ring stem seals

Positive shutoff- exceeds Class VI

Blow out proof stainless steel stem

### Advantages of 4000 Series

vs. Plug Valves

Full unobstructed flow

No exposed internal components to catch and retain debris

No lubrication required to ensure smooth operation and maintain seals

Lower torque for more efficient and cost effective automation

Positive shutoff- exceeds Class VI

# Applications

for the 4000 Series Valves

## Plumbing

Pump Isolation

---

Water Main Shutoff

---

Hi-Rise Building Booster Pumps

---

Drain Lines

---

Lead and VOC Free Materials contribute to Green Infrastructure

## Water Treatment

Plumbing Isolation

---

Building Connections

---

Pump Stations

---

Chemical Feed Lines

## Wastewater Plants

Digester Aerators

---

Sludge Processing

---

Methane Gas Gathering, Storage, and Distribution

---

Force Mains

---

Lift Stations

---

Chemical Feed Lines

---

Drain Lines

## Irrigation

Golf Courses

---

Citrus Groves

---

Farm Fields

---

Public Parks

---

Sports Facilities

---

Livestock

## Industrial

Mining

---

BioDiesel and Ethanol Production, Storage, and Distribution

---

Petroleum Blending, Storage, and Distribution

---

Petroleum Loading Facilities

---

Food Processing

---

Plant Utilities

---

Power Plants

---

Air Lines

---

Drain, Waste, and Vent Lines

## HVAC

Boiler Feed

---

Makeup Water

---

Distribution of Hot Water or Steam from Central Plant

---

Condensate Return

---

Distribution and Return of Chilled Water from Central Chilled Water Plant

---

Drain Lines

## Gas

Natural Gas Meter Sets

---

Propane Gas Storage and Distribution



## More Than Just a Valve



**American Valve** offers a complete package of pneumatic, hydraulic and electric actuators, gear operators and operating nuts for the 4000 series. Our unique PFA\* fused ball and lower operating torques make the 4000 series an effective alternative to cast iron gates, carbon steel ball valves, carbon steel gate valves, and plug valves. Our in-house automation program provides a fast, cost-effective, and turn-key solution for your automation needs.

Pneumatic, hydraulic and electric actuators made for the 4000 series have an unmatched cycle life and are the industry-wide preference for even the most severe

applications. These actuators offer adaptability to a variety of process conditions to accommodate your application.

The flexible, modular design of the patented 4000 series can be used to combine actuators, solenoid valves, limit switches and other accessories in a variety of applications. American Valve delivers the 4000 series fully automated and factory tested under a single manufacturer's warranty.

Standard 2" square operating nuts are available to effectively satisfy underground requirements.

*\*PFA is an ingredient commonly branded as Teflon®.*

## A SPECIAL PACKAGE FOR WHOLESALERS

American Valve has also created unique, sturdy boxes for the patented family of 4000 ball valves. This exclusive packaging eliminates potential shipping damage and offers unparalleled storage capabilities to wholesalers.



# American Valve

## PFA\* Fused Ball



Our PFA\* fused ball is more corrosion-resistant than balls made with unprotected metal surfaces. Refer to any manufacturer's chemical resistance guide for further information.

Our PFA\* fused ball inhibits the buildup of lime, calcium, sludge, etc. that accumulates on ball surfaces and thus prevents premature failure of the valve seats. Series 4000 valves with Teflon® fused balls can last up to ten times longer than valves made with unprotected ball surfaces.

The lubricity of our PFA\* fused ball allows for lower torque ratings in any application.

This feature eliminates ball pitting, prevents build-up, lowers torque, and stops premature valve failure.

Since the PFA\* is actually impregnated .008" into the solid metal, it can't wear, chip, or flake off.

\*PFA is an ingredient commonly branded as Teflon®.



## A Look Inside Our Ball

PFA\* surrounds the base material to form a fused bond to a depth of .008

Additional .004" electrostatic coating for smoothness.

Together they produce the strength of steel with the corrosion resistance of PFA\*. Our patented process has gained the best of both worlds...Strength, Lubricity, and Bonding.

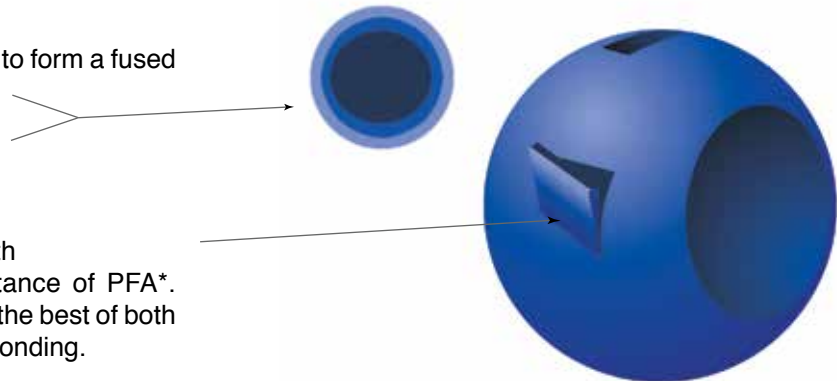

\*PFA is an ingredient commonly branded as Teflon®.

# Metallurgy

## Technical Info for 4000 Series

	Minimum Tensile Strength	Minimum Yield Point	Minimum Elongation
Grey Iron A126 Class B	31,000 psi	---	0.1%
Ductile Iron A536 Grade 65-45-12	65,000 psi	45,000 psi	12%
Carbon Steel A216 WCB	70,000 psi	30,000 psi	22%
304 Stainless Steel A-351 CF8	70,000 psi	28,000 psi	35%
316 Stainless Steel A-351 CF8M	70,000 psi	30,000 psi	30%

	GREY IRON	65-45-12 DUCTILE IRON	WCB	CF8	CF8M
Carbon % (max)	3.5	3.5	0.3	0.08	0.08
Manganese %	0.5	0.1	1.0	1.5	1.5
Phosphorous %	0.1	0.03	0.04	0.04	0.04
Sulfur %	0.1	0.005	0.05	0.04	0.04
Nickel %	0.02	0	0.5	8.0	9.0
Chromium %	0.05	0.025	0.04	18-21	18-21
Molybdenum %	0.05	0.002	0.25	-	2-3
Silicon %	2.1	3.2	0.3	2	2
Magnesium %	0.005	0.025	-	-	-

Model 4000 is made of cast iron (ASTM A126 Class B, standard grey iron). Model 4000D is made of ductile iron (ASTM 536, grade 65-45-12). Model 4001 is made of stainless steel (ASTM A351 CF8M).

It is useful to understand basic information about ferrous metals (cast irons, steels) and their relationships. 100% pure iron is never used as a cast metal because it is too soft and weak. When carbon is added, hardness and strength appear. When approximately 0.3% carbon is added, the resulting alloy is steel. Steel is a strong but difficult ferrous metal to manufacture from a production standpoint. Adding more carbon (up to about 2%) creates even more production problems. These "semi-steels" are seldom used.

When more carbon is added (between 2% and 3%), white iron is formed. White iron is true cast iron and is easy to produce. The problem with white iron is that it is very brittle because the carbon exists as iron carbide instead of pure carbon. Iron carbide (Fe<sub>3</sub>C) is a hard and brittle compound sometimes referred to as cementite. If white iron is subjected to a lengthy heat treatment, the Fe<sub>3</sub>C decomposes into iron and nodules of graphite. The end product is malleable iron.

When approximately 3.5% carbon is added, Fe<sub>3</sub>C exceeds its solubility in solid iron (the Fe<sub>3</sub>C is fully absorbed in the iron until there is no room left. The excess Fe<sub>3</sub>C is dispersed as graphite flakes). The result is grey iron. Grey iron (standard cast iron) delivers only moderate strength with almost no elongation because the excess Fe<sub>3</sub>C flakes act as stress raisers (they make cast iron easy to crack). Since grey iron is so economical to produce, its use has been widespread for centuries.

Cast Iron with spheroidal graphite (ductile iron) was first produced in 1948. Its chemical composition and percent of carbon is about the same as grey iron. The transformation to ductile iron occurs when molten grey iron is treated with magnesium. The insertion of magnesium into the pouring ladle (the process is called inoculation) transforms the Fe<sub>3</sub>C flakes into spheroids. These spheroids strengthen the metal by acting as crack arresters instead of crack facilitators. Ductile iron is sometimes referred to as spheroidal or nodular iron.

65-45-12 ductile iron is named for its physical properties (65,000 psi tensile strength, 45,000 psi yield, 12% elongation). Ductile iron chemically can be manufactured as Ferritic or Pearlitic. In Ferritic mixes, the graphite spheroids are in a matrix of pure iron. In Pearlitic mixes, the graphite spheroids are in a matrix of pure iron and cementite (Fe<sub>3</sub>C). The most common grade of ductile is Pearlitic-Ferritic, a combination of the two. American Valve's 4000D uses a predominately Ferritic mix (9:1) to take advantage of its high impact resistance and added tensile strength (80,000 psi).

Except where API 800° F fire safe standards are required for petrochemical refineries, **ductile iron is generally preferable to a carbon steel** because WCB has a tendency to flake, whereas ductile iron powders when subjected to liquid erosion. Ductile iron also possesses 50% higher yield strength properties and is more cost effective. Ductile iron castings have a maximum temperature rating of 650 degrees F. Traditional glass reinforced PTFE seats begin to deform at 360 degrees F.

ASTM A536-70 (MIL SPEC D-4512) requires each casting to be marked by its foundry heat number. Each heat is chemically tested prior to magnesium inoculation and also afterwards. Chemical certification by heat number is available upon request.

Standard cast steel (carbon steel) uses the symbol WCB and is defined under ASTM A-216. It contains a maximum of 0.3% carbon. Stainless steel (ASTM A-351) has carbon levels even lower than WCB (0.08% maximum) making its production more costly. 304 Stainless Steel (CF8) adds 8% nickel, about 20% chromium, and a little more silicon. 316 stainless steel (CF8M) adds 2-3% molybdenum to the above. The addition of chromium, nickel and molybdenum enhances corrosion resistance, allowing CF8M to be utilized in a wide variety of chemical, petrochemical, and corrosive environments.

# Operating Torques

## for 4000 Series Ball Valve

Size	Torque (ft. lbs)
1/2"	10
3/4"	10
1"	10
1 1/2"	20
2"	35
2 1/2"	48
3"	62
4"	130
6"	260
8"	360
10"	535

The actual amount of torque required to operate a valve is dependent upon many variables, such as line pressure, temperature, type of fluid, and frequency of operation. This table is based on average breakaway torque requirements for a valve handling a clean, particle-free liquid such as water. The following chart includes a safety allowance for service conditions. The torque figures listed should be further adjusted for dry or special service conditions. For fluids with high solids or abrasive content, consult factory for recommendations.

### GEAR OPERATOR DIMENSIONS:

Size	A	B	C	D	E	F	G	H	I	J	DH	Ratio	TOFP*
1 1/2" - 4"	6"	7"	3.875"	4.75"	2.375"	10.5"	3"	2.75"	1.75"	0.79"	9.875"	1:30	515
6"-10"	6"	7"	3.875"	4.75"	2.375"	7.75"	3"	2.75"	1.75"	0.79"	11.875"	1:50	885

\* Torque Output Foot-Pounds

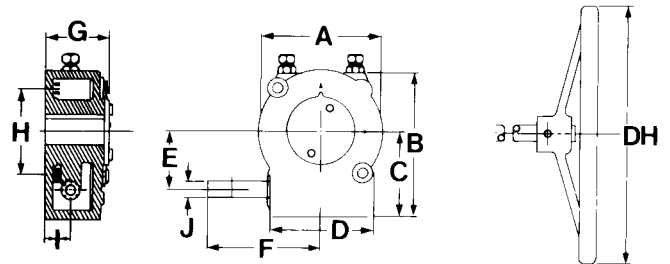

### MOUNTING PAD DIMENSIONS:

Size	A	B	C	D	E	F	G	H	J	K	L	M	N
1/2	2.37	1.75	1.565	0.57	1.14	0.57	1.14	0.5	1.5	2 x M8	4 x .25UNC	0.31	0.67
3/4	2.37	1.75	1.565	0.57	1.14	0.57	1.14	0.5	1.5	2 x M8	4 x .25UNC	0.31	0.67
1	2.37	1.75	1.565	0.57	1.14	0.57	1.14	0.5	1.5	2 x M8	4 x .25UNC	0.31	0.67
1 1/2	3.62	2.746	2.323	0.985	1.97	0.985	1.97	0.825	2.1	2 x M12	4 x M8	0.47	1.495
2	3.62	2.746	2.323	0.985	1.97	0.985	1.97	0.825	2.1	2 x M12	4 x M8	0.47	1.495
2 1/2	4.725	3.74	2.957	1.418	2.835	1.418	2.835	1.1	2.4	2 x M12	4 x .4375UNC	0.665	1.81
3	4.725	3.74	2.957	1.418	2.835	1.418	2.835	1.1	2.4	2 x M12	4 x .4375UNC	0.665	1.81
4	4.725	3.74	2.957	1.418	2.835	1.418	2.835	1.1	2.4	2 x M12	4 x .4375UNC	0.665	1.81
6	5.16	4.725	3.465	1.733	3.465	1.733	3.465	1.775	2.75	2 x .5UNC	4 x .5UNC	1.06	2.205
8	5.16	4.725	3.465	1.733	3.465	1.733	3.465	1.775	2.75	2 x .5UNC	4 x .5UNC	1.06	2.205
10	5.16	4.725	3.465	1.733	3.465	1.733	3.465	1.775	2.75	2 x .5UNC	4 x .5UNC	1.06	2.205

Dimensions and weights are given as approximates; consult factory for details.

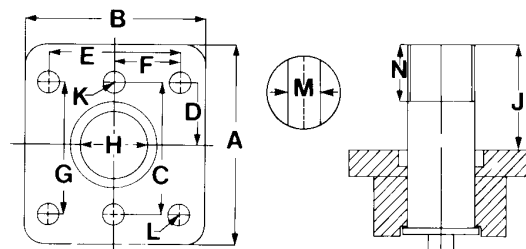



*Industry-Leading Innovation*

[www.americanvalve.com](http://www.americanvalve.com)

*Member of the Valve Manufacturers Association of America*

**ISO 9001 Registered**

P.O. Box 35229, Greensboro NC 27425  
ph. 800-645-0101 fax. 800-876-0109

© 2012 American Valve, Inc, all rights reserved