

COMMERCIAL FLUSH VALVES



DELTA.® AS INDIVIDUAL AS YOUR PROJECTS.



For the architects and engineers who specify commercial plumbing products, as well as the property owners, guests, residents, patrons and workers who use them—Delta is a trusted brand. Because Delta commercial products go beyond providing exceptional commercial-grade performance with products that reflect the personality of the individual institution. From electronic (exposed, concealed or wallmount sensed) water closets and urinals to an assortment of manual and retrofitting options, Delta offers a full range of applications to help you meet your current and future needs.

Delta believes there is a better way to live with water and has developed smart solutions that meet the unique requirements presented by each commercial environment. Providing individuals with a better way to experience water, while standing up to prolonged, rigorous use. And, most Delta commercial products are backed by the industry's best 5-year limited warranty.

Delta commercial products are thoroughly tested and inspected to industry standards throughout the manufacturing and assembly process. In fact, every valve is tested before leaving our manufacturing facility so you can install with confidence and ease – guaranteed.

Style meets performance with Delta commercial plumbing products that not only provide long life, but also enhance their environments. That's why we focus on providing products that feature the latest innovations.

ICONS:

 = H₂Optics™ Technology
(See page 5 for a full explanation of H₂Optics Technology)

 = ADA

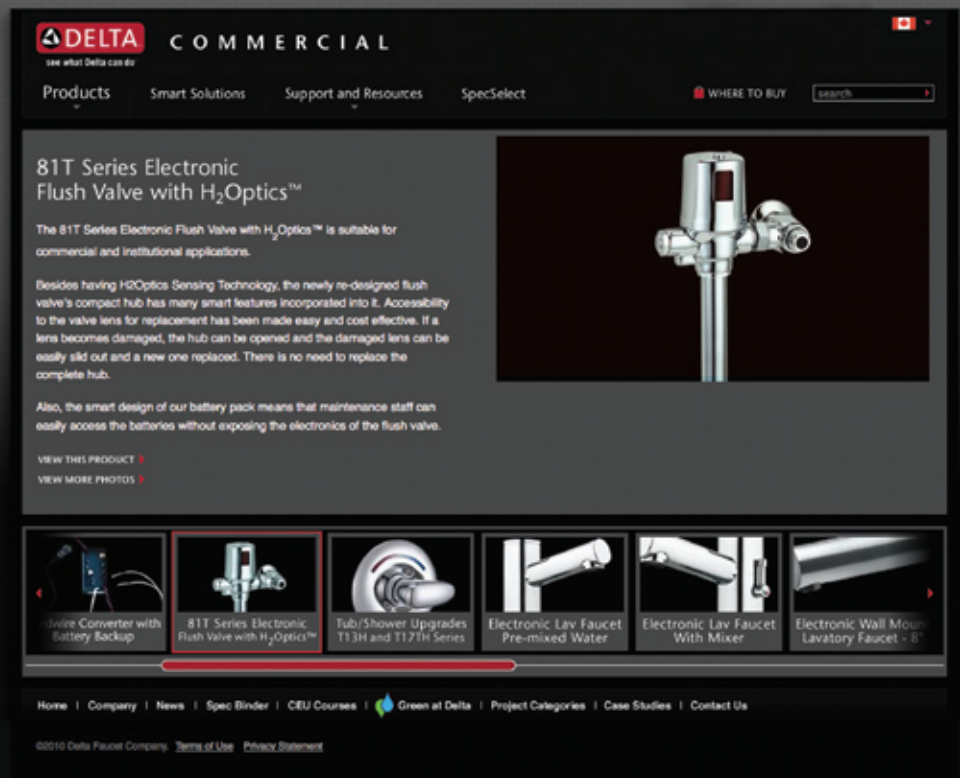

DELTA COMMERCIAL WEBSITE | deltacommercialfaucets.com

Delta's user-friendly commercial website features our most popular and newest products plus technology information. You can quickly search products by: project type, newer products or model number. You can also view in-depth information on Delta's Smart Solutions, read up on case studies, download literature, search for a distributor location or have seamless access to specs and maintenance and installation sheets via SpecSelect. Everything you need to make your selection easier is right online.

SPECSELECT® | specselect.com

SpecSelect is a state-of-the-art tool that delivers specific and instantaneous information for sourcing commercial products. Explore over 40,000 models for all your project needs whether renovating a healthcare facility, designing a hotel, or specifying a new college, you won't find a more comprehensive online catalogue than SpecSelect.

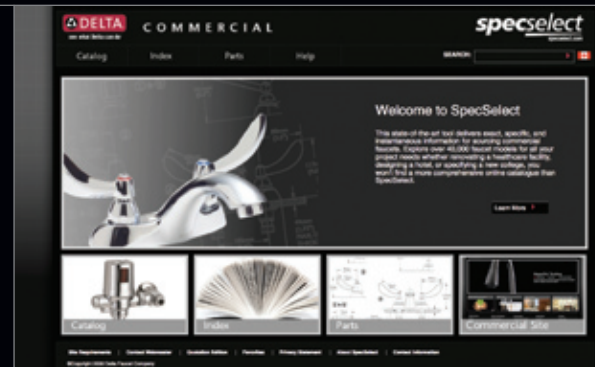

SUPPORT.

Delta Sales Representatives are fully trained to assist you in identifying the best product for your particular application and environment. Additionally, Delta's Customer Service and Technical Service Representatives are intensively trained on product and installation so that you can get assistance when you need it. Help is just a phone call away at 1.800.567.3300.

FLUSH VALVES WITH SUSTAINABLE DESIGN.

REGARDLESS OF YOUR FLUSHING NEEDS, DELTA HAS YOU COVERED WITH OUR TECK® SERIES OF INSTITUTIONAL HEAVY WEIGHT FLUSH VALVES.

Delta's TECK series of flush valves are among the highest quality engineered valves available today. TECK flush valves are designed to withstand the rigors of public facility use day after day. Most Delta TECK valves include an external regulating adjustment screw that can accommodate various flush volume requirements. Hence, these flush valves can now be set at lower flush rates than previously offered, making these TECK series of flush valves ideal for LEED® projects.

In addition, Delta TECK's fixed flow 4.8 Lpf (1.27 gpf) water closet flush valves, both electronic and manual, provide up to 20% water savings* over a 6 L flush valve with each use and are a perfect alternative to dual flush valves, which are also offered.

Urinal valves, both electronic and manual, can now be adjusted from 0.47 to 3.78 Lpf (0.125 to 1.0 gpf), which offers substantial water savings when a valve is set at flow rates of 1.9 Lpf (0.5 gpf) and lower, compared to traditional 3.78 Lpf (1 gpf) urinals.

Delta's TECK series of flush valves feature superior technology and provide customers with options to meet their personal needs.

*Flush valves are available with flows that provide a 4.8 Lpf (1.27 gpf) resulting in a 20% savings compared CSA B125.3 standard 6.0 Lpf (1.6 gpf) models.

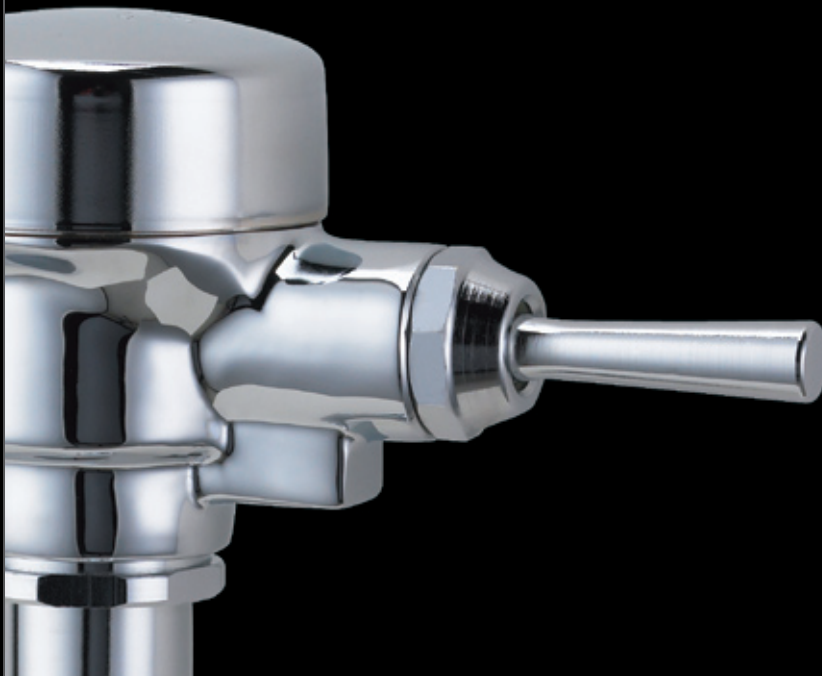

SMART SOLUTIONS: HANDS-FREE INNOVATION.

H₂OPTICS™ TECHNOLOGY.

Responsiveness is key with hands-free functionality. Delta electronic faucets and flush valves with H₂Optics Technology operate consistently, time after time, regardless of interference factors such as dark clothing or lighting conditions. All electronic faucets and flush valves featuring H₂Optics Technology are water efficient*—which can also help contribute to LEED® certification.

Suitable for commercial and institutional applications, Delta's H₂Optics technology is one of the most advanced sensing technologies in the industry today for electronic faucets and flush valves. With the ability to accurately sense the user's distance, regardless of external factors such as light reflection, clothing colour and textures or dryness of one's skin, H₂Optics provides consistent, dependable results.

Using the principles of triangulation, H₂Optics measures the angle of the returned beam to detect the user, resulting in a reliable performance.

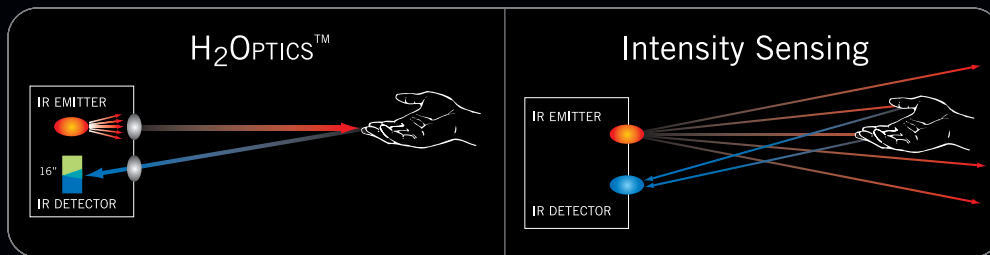

With superior sensing, the infrared technology calculates distance and activates when an object is placed within a set proximity. Other infrared technology works on the intensity of light, which may detect outside influences and cause the faucet or toilet to activate unnecessarily, one of the key concerns of those in the industry.

With a response time of four pulses per second, H₂Optics provides a good balance between reaction time and battery conservation. Delta now provides both faucets and flush valves with H₂Optics technology, so contractors and plumbers can have the peace of mind that comes with working with just one supplier.

Developed by Delta Faucet, this innovative technology was designed and produced in North America. H₂Optics is available now on several Delta commercial products.

*Water-Efficient Product—Lavatory faucets: flow rate of 1.5 gpm @ 60 psi, 5.7 L/min @ 414 kPa as compared to the Industry Standard ASME.A112.18.1/CSA.B125.1 of 2.2 gpm @ 60 psi, 8.3 L/min 414 kPa.



ELECTRONIC FLUSH VALVES.

Delta's electronic products lead the industry with a forward thinking electronics platform that will be available for many years to come. Our advanced electronics technology is designed to help eliminate false activations to help you conserve water. Our products are also easily convertible from battery to hardwire – it's your choice.

In addition, our electronic flush valves are also available with a Hardwire Converter with Battery Backup option (see page 11). This is ideal for hardwire installations where valves have not been installed on the building's emergency backup system in the event of power outages. This is just another way Delta provides you with the ability to customize to your needs.



81T231-WMSHW – Hardwire
81T231-WMSBT – Battery



Battery life indicator

81T201HWA – Hardwire
81T201BTA – Battery

81T SERIES WITH H₂OPTICS.™

Introducing Delta Faucet company's 81T Series Electronic Flush Valve with H₂Optics.™ Suitable for commercial and institutional applications, Delta's H₂Optics hands-free technology is one of the most advanced sensing technologies in the industry today for electronic faucets and flush valves.

Besides having H₂Optics Sensing Technology, the newly re-designed flush valve's compact hub has many smart features incorporated into it. Accessibility to the valve lens for replacement has been made easy and cost effective. If a lens becomes damaged, the hub can be opened to easily slide out the damaged lens and a new lens inserted. There is no need to replace the complete hub.

Also, the smart design of our battery pack means that maintenance staff can easily access the batteries without exposing the electronics of the flush valve. Checking battery life is easy with the 81T Series external battery strength indicator. This smart design allows viewing the battery life by simply holding down the over ride button for 10 seconds.



EXPOSED ELECTRONIC WATER CLOSET FLUSH VALVE

81T201HWA – Hardwire

81T201BTA – Battery

- Volume control, field adjustable
- Chloramine-resistant diaphragm
- Metal manual override button
- Dual flush capability
- Replaceable lens window
- Battery life indicator
- Flow rate options available



EXPOSED ELECTRONIC WATER CLOSET DUAL FLUSH VALVE

81T201HWA-DF – Hardwire

81T201BTA-DF – Battery

- Volume control, field adjustable
- Chloramine-resistant diaphragm
- Metal manual override button
- Factory set dual flush
- Replaceable lens window
- Battery life indicator
- Flow rate options available



EXPOSED ELECTRONIC URINAL FLUSH VALVE

81T231HWA – Hardwire

81T231BTA – Battery

- Volume control, field adjustable
- Chloramine-resistant diaphragm
- Metal manual override button
- Replaceable lens window
- Battery life indicator
- Flow rate options available



EXPOSED ELECTRONIC WATER CLOSET FLUSH VALVE WITH WALLMOUNT SENSOR

81T201-WMSHW – Hardwire

81T201-WMSBT – Battery

- Chloramine-resistant diaphragm
- Metal manual override button
- Vandal resistant stainless steel cover
- Battery life indicator
- Flow rate options available



EXPOSED ELECTRONIC URINAL FLUSH VALVE WITH WALLMOUNT SENSOR

81T231-WMSHW – Hardwire

81T231-WMSBT – Battery

- Chloramine-resistant diaphragm
- Metal manual override button
- Vandal resistant stainless steel cover
- Battery life indicator
- Flow rate options available



Did you know?

Delta now offers both electronic and manual flush valves which deliver 1 Pint per flush (0.47 Lpf / 0.125 gpf), making these valves a perfect alternative to waterless urinals.



81T201-WMSHW – Hardwire
81T201-WMSBT – Battery



CONCEALED ELECTRONIC WATER CLOSET FLUSH VALVE

1600T6103 – Hardwire

1601T6103 – Battery

- Metal manual override button
- Vandal-resistant stainless steel cover
- Available in various rough-in and trim options which can be ordered separately when required
- Battery or hardwire operation
- Battery life indicator
- Flow rate options available



CONCEALED ELECTRONIC WASHDOWN URINAL

1600T9001

- Metal manual override button
- Vandal-resistant stainless steel cover
- Available in various rough-in and trim options which can be ordered separately when required
- Battery or hardwire operation
- Battery life indicator
- Flow rate options available



MANUAL FLUSH VALVES.

Complete with an external adjustment screw that can accommodate various flush volume requirements or, if desired, fixed volume models are also available. Delta's manual flush valve products are built to meet the demands of public restrooms.



81T231

Part of Delta's solution is having the flexibility to customize products – easily. In addition to providing optional flush valve flow rates, Delta also offers trap seal primers to help prevent any odours from coming up the floor drain, disinfectant tees to pull some sanitizer into the toilet bowl, seat bumpers to help protect damage to seat covers, adjustable tails to retrofit your projects to your specifications, optional filter screens to protect large particulate matter from entering which is common in new construction and much more. Some of Delta's additional flush valve features include:

- CSA Certified
- Concealed Spud Nut (Sanitary)
- Vacuum Breaker
- Constant Peak Flow
- Copper Sweat Inlet Adaptor – 1" (3/4" on Urinal valves)
- Chloramine Resistant Diaphragm
- Heavy Duty
- Marine/Ship Use
- Renewable Seat
- Quiet Action
- Vandal Resistant
- ADA Compliant Lever Handle



81T201



- WATER CLOSET FLUSH VALVE**
81T201
- Volume control, field adjustable
 - Chloramine-resistant diaphragm
 - ADA vandal-resistant non-hold open handle
 - Flow rate options available



- URINAL FLUSH VALVE**
81T231
- Volume control, field adjustable
 - Chloramine-resistant diaphragm
 - ADA vandal-resistant non-hold open handle
 - Flow rate options available



- METERING WASHDOWN URINAL VALVE**
86T505
- ADA vandal-resistant handle
 - Adjustable close time
 - Solid brass construction



- WATER CLOSET FLUSH VALVE**
81T261
- With 610mm (24") "A" length and 38mm (1 1/2" offset)
 - Chloramine resistant diaphragm
 - Forged brass diaphragm retainer
 - Renewable seat
 - Polished chrome plated finish
 - Vandal resistant cover screw
 - Metal non-hold open handle
 - Flow rate options available



A variety of handle options available

- CONCEALED WATER CLOSET FLUSH VALVE**
83T141
- Quiet action, TECK concealed diaphragm flush valve
 - Vandal-resistant handle control can easily be installed anywhere within 6 m (20') of flush valve
 - Renewable seat
 - Oscillating lever handle
 - Chloramine resistant diaphragm
 - Flow rate options available



Did you know?

You can choose from a variety of fixed or adjustable flow rates to customize your commercial flush valve. Some of our flush valves have an external adjustment screw and can accommodate various flush volume requirements. Delta's flow rate options provide you with flexibility to meet your personal needs. For flush valve flow rate options see chart below.

DELTA'S FLUSH VALVE VARIATIONS

(For preferred flow rate add suffix number to the end of your flush valve model number)

SUFFIX NUMBER	DESCRIPTION
WATER CLOSET	Standard Flush 6 Lpf (1.6 gpf) Factory set at 60 psi – Field Adjustable
-6	6 Lpf (1.6 gpf), Factory Set Flush, Not Field Adjustable
-13	13 Lpf (3.4 gpf) Factory Set Flush, Field Adjustable
-48	4.8 Lpf (1.27 gpf) Factory Set Flush, Not Field Adjustable
URINALS	Standard Flush 1.9 Lpf (0.5 gpf) Factory set at 60 psi – Field Adjustable
-5	0.5 Lpf (0.13 gpf) Factory Set Flush, Not Field Adjustable
-19	1.9 Lpf (0.5 gpf) Factory Set Flush, Not Field Adjustable
-38	3.8 Lpf (1.0 gpf) Factory Set Flush, Not Field Adjustable

RETROFITTING OPTIONS.

Delta offers an array of retrofitting options to provide you with flexibility. Retrofit your manual flush valve with an electronic unit and enjoy all the benefits of hands-free operation.

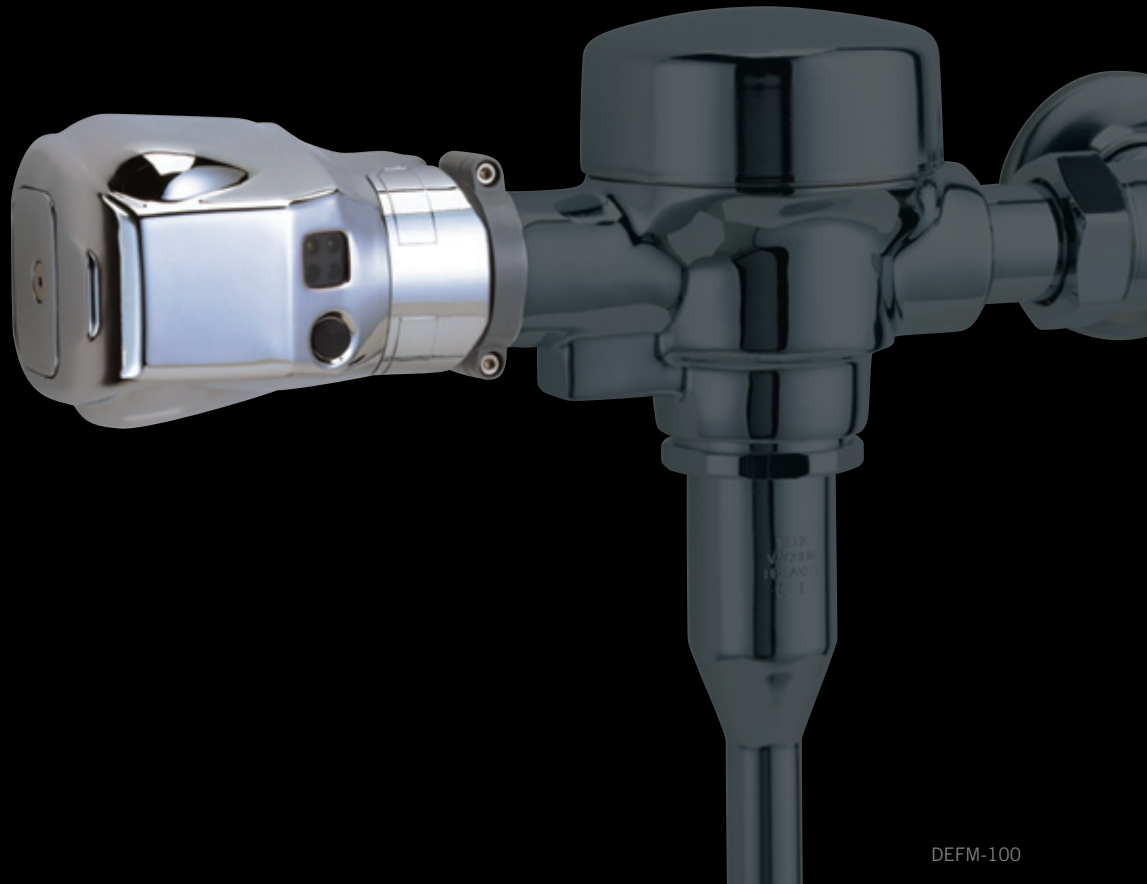

DEFM-100

DEFM-100: DELTA'S BATTERY OPERATED SIDE MOUNT FLUSH KIT.

Have you ever wanted to upgrade to hands-free flush valves but thought it was too expensive or would take too much of your time? Now Delta makes retrofitting your manual flush valves quick, easy and cost effective with the Electronic Side Mount Flush Kit.

Retrofitting only takes minutes with no need to turn off the water. The adapter supplied in each box allows the battery operated side mount flusher to be easily fitted to Crane®, Zurn®, Sloan® and TECK® flush valves, including our popular Tempus® Series.





**SIDE MOUNT ELECTRONIC FLUSH KIT
DEFM-100**

- For use on 81T TECK® exposed manual flush valves and 86T metering washdown urinals
- Can also be used on Sloan®, Zurn® and Crane® models
- Courtesy manual flush button
- Batteries included



ELECTRONIC FLUSH RETROFIT KIT

- 81T201BTA-20 – Battery water closet
- 81T201HWA-20 – Hardwire water closet
- Complete valve less stop, cover tube and wall flange
- Chloramine-resistant diaphragm
- Metal manual override button
- Replaceable lens window
- Urinal models available
- Battery life indicator
- Dual flush capability
- Retrofit to Delta TECK stop



ELECTRONIC FLUSH RETROFIT KIT

- 81T201BTA-30 – Battery water closet
- 81T201HWA-30 – Hardwire water closet
- Complete valve less stop with modified tail to fit Sloan/Zurn stop
- Chloramine-resistant diaphragm
- Metal manual override button
- Replaceable lens window
- Urinal models available
- Battery life indicator
- Dual flush capability



ELECTRONIC FLUSH RETROFIT KIT

- 81T231BTA-20 – Battery urinal
- 81T231HWA-20 – Hardwire urinal
- Complete valve less stop with cover tube and wall flange
- Chloramine-resistant diaphragm
- Metal manual override button
- Replaceable lens window
- Water closet models available
- Battery life indicator
- Dual flush capability
- Retrofit to Delta TECK stop



ELECTRONIC FLUSH RETROFIT KIT

- 81T231BTA-30 – Battery urinal
- 81T231HWA-30 – Hardwire urinal
- Complete valve less stop with modified tail to fit Sloan/Zurn stop
- Chloramine-resistant diaphragm
- Metal manual override button
- Replaceable lens window
- Water closet models available
- Battery life indicator
- Dual flush capability



Did you know?

The Hardwire Converter with Battery Backup (model# 061047A) provides stability and peace of mind in the event of power failures and outages. If power is lost, the battery backup allows your electronic faucets, flush valves and urinals to run until power has fully been restored.



Did you know?

Our flush valves represent a simple valve requiring minimal to no maintenance and our repair parts are readily available for order. Depend on Delta to provide you with the support you need.



ELECTRONIC FLUSH RETROFIT KIT

- 81TWCBTRKA – Water closet
- 81TURBTRKA – Urinal
- Battery operation
- Converts Delta TECK manual exposed flush valves to electronics
- New diaphragm, seat and filter screen included
- For hardwire kit, order 060929A
- Replaceable lens window





Delta® is committed to sustainability and providing smart water delivery solutions that maximize water savings without sacrificing comfort and convenience. Our commitment to sustainability extends to waste reduction and the preservation of natural resources and the environment. That's why we print on Forest Stewardship Council (FSC) certified paper made with renewable energy.



see what Delta can do

A MASCO COMPANY

Masco Canada Limited, Plumbing Group
395 Matheson Blvd. East
Mississauga, Ontario L4Z 2H2

deltacommercialfaucets.com
specselect.com
800.567.3300

©2010 Masco Canada Limited
All rights reserved.
MKT-09-090

