

DLFCAB / DLCCAR / DLFCHB / DLCCHR DLFDAB / DLCDAR / DLFHDB / DLCDHR

INSTALLATION INSTRUCTIONS

High Wall Ductless Split System – Sizes 09 to 36

NOTE: Read the entire instruction manual before starting the installation.



TABLE OF CONTENTS

	PAGE
SAFETY CONSIDERATIONS	2
GENERAL	2
SYSTEM REQUIREMENTS	2
Piping	2
PIPING AND REFRIGERANT TABLES DLFCAB / DLCCAR / DLFCHB / DLCCHR	3
PIPING AND REFRIGERANT TABLES DLFDAB / DLCDAR / DLFDHB / DLCDHR	4
DIMENSIONS-INDOOR	6
DIMENSIONS-OUTDOOR	7
CLEARANCES-INDOOR	8
CLEARANCES-OUTDOOR	8
INSTALLATION GUIDE	9
INDOOR UNIT INSTALLATION	9
Install Mounting Plate	9
Drill Hole in Wall for Interconnecting Piping, Drain and Wiring	9
OUTDOOR UNIT INSTALLATION	9
Piping Connections to Outdoor Unit	9
INSTALL ALL POWER, INTERCONNECTING WIRING AND PIPING TO INDOOR UNIT	11
SYSTEM VACUUM AND CHARGE	11
START-UP	13
WIRING DIAGRAMS	14
TROUBLESHOOTING	15

The following parts are included in your indoor unit. Please contact your dealer if any parts are damaged or missing.

Table 1—Parts List

Parts	Qty
Mounting Plate	1
Mounting Hardware	7
Remote Control	1
Remote Control Holder	1
Battery (1.5V)	2

SAFETY CONSIDERATIONS

Installing, starting up, and servicing air-conditioning equipment can be hazardous due to system pressures, electrical components, and equipment location (roofs, elevated structures, etc.).

Only trained, qualified installers and service mechanics should install, start-up, and service this equipment.

Untrained personnel can perform basic maintenance functions such as cleaning coils. All other operations should be performed by trained service personnel.

When working on the equipment, observe precautions in the literature and on tags, stickers, and labels attached to the equipment.

Follow all safety codes. Wear safety glasses and work gloves. Keep quenching cloth and fire extinguisher nearby when brazing. Use care in handling, rigging, and setting bulky equipment.

Read these instructions thoroughly and follow all warnings or cautions included in literature and attached to the unit. Consult local building codes and current editions of the National Electrical Code (NEC) NFPA 70. In Canada, refer to current editions of the Canadian electrical code CSA 22.1.

Recognize safety information. This is the safety-alert symbol . When you see this symbol on the unit and in instructions or manuals, be alert to the potential for personal injury. Understand these signal words: DANGER, WARNING, and CAUTION. These words are used with the safety-alert symbol. DANGER identifies the most serious hazards which **will** result in severe personal injury or death. WARNING signifies hazards which **could** result in personal injury or death. CAUTION is used to identify unsafe practices which **may** result in minor personal injury or product and property damage. NOTE is used to highlight suggestions which **will** result in enhanced installation, reliability, or operation.



WARNING

ELECTRICAL SHOCK HAZARD

Failure to follow this warning could result in personal injury or death.

Before installing, modifying, or servicing system, main electrical disconnect switch must be in the OFF position. There may be more than 1 disconnect switch. Lock out and tag switch with a suitable warning label.



CAUTION

EQUIPMENT DAMAGE HAZARD

Failure to follow this caution may result in equipment damage or improper operation.

Do not bury more than 36 in. (914 mm) of refrigerant pipe in the ground. If any section of pipe is buried, there must be a 6 in. (152 mm) vertical rise to the valve connections on the outdoor units. If more than the recommended length is buried, refrigerant may migrate to the cooler buried section during extended periods of system shutdown. This causes refrigerant slugging and could possibly damage the compressor at start-up.

GENERAL

These instructions cover the installation, start-up and servicing of outdoor and indoor units ductless systems.

SYSTEM REQUIREMENTS

Allow sufficient space for airflow and servicing unit. See Fig. 4 for minimum required distances between unit and walls or ceilings.

Piping

IMPORTANT: Both refrigerant lines must be insulated separately.

- Minimum refrigerant line length between the indoor and outdoor units is 10 ft. (3 m).
- The following maximum lengths are allowed.

PIPING AND REFRIGERANT TABLES DLFCAB / DLCCAR / DLFCHB / DLCCHR

Table 2—Piping Information DLFCAB / DLCCAR / DLFCHB / DLCCHR

System Size		9K	12K	9K	12K	18K	24K	30K	36K
Voltage		115/1/60	115/1/60	208/230-1-60	208/230-1-60	208/230-1-60	208/230-1-60	208/230-1-60	208/230-1-60
Min. Piping Length	ft	10	10	10	10	10	10	10	10
	m	3	3	3	3	3	3	3	3
Standard Piping Length	ft	25	25	25	25	25	25	25	25
	m	7.5	7.5	7.5	7.5	7.5	7.5	7.5	7.5
Max. Outdoor-Indoor Height Difference	ft	32.8	32.8	32.8	32.8	32.8	32.8	32.8	32.8
	m	10	10	10	10	10	10	10	10
Max. Piping Length w/ No Additional Refrigerant Charge	ft	25	25	25	25	25	25	25	25
	m	7.5	7.5	7.5	7.5	7.5	7.5	7.5	7.5
Max. Piping Length	ft	49.2	65.6	49.2	65.6	82	82	98.4	98.4
	m	15	20	15	20	25	25	30	30
Gas Pipe (size - connection type)	in	3/8	1/2	3/8	1/2	1/2	5/8	5/8	5/8
Liquid Pipe (size - connection type)	in	1/4	1/4	1/4	1/4	1/4	1/4	1/4	1/4

Table 3—Refrigerant Information DLFCAB / DLCCAR / DLFCHB / DLCCHR

System Size		9K	12K	9K	12K	18K	24K	30K	36K	
Voltage		115/1/60	115/1/60	208/230-1-60	208/230-1-60	208/230-1-60	208/230-1-60	208/230-1-60	208/230-1-60	
Cooling Only	Refrigerant Type	--	R410A	R410A	R410A	R410A	R410A	R410A	R410A	
	Charge Amount	Oz	42.3	47.6	45.9	47.6	56.4	81.1	84.66	84.7
		Kg	1.2	1.35	1.3	1.35	1.6	2.3	2.4	2.4
	Additional Refrigerant Charge (between Standard – Max Piping Length)	Oz/ft	0.161	0.161	0.161	0.161	0.161	0.161	0.161	0.16
		g/m	15	15	15	15	15	15	15	15
Heat Pump	Refrigerant Type	--	R410A	R410A	R410A	R410A	R410A	R410A	R410A	
	Charge Amount	Oz	42.3	47.6	45.9	47.6	56.4	77.6	84.66	91.7
		kg	1.2	1.35	1.3	1.35	1.6	2.2	2.4	2.6
	Additional Refrigerant Charge (between Standard – Max Piping Length)	Oz/ft	0.215	0.215	0.215	0.215	0.161	0.538	0.538	0.54
		g/m	20	20	20	20	15	50	50	50

PIPING AND REFRIGERANT TABLES DLFDAB / DLC DAR / DLFDHB / DLC DHR

Table 4— Piping Information DLFDAB / DLC DAR / DLFDHB / DLC DHR

System Size		9K	12K	9K	12K	18K	24K	30K*	36K*
Voltage		115/1/60	115/1/60	208/230-1-60	208/230-1-60	208/230-1-60	208/230-1-60	208/230-1-60	208/230-1-60
Min. Piping Length	ft	10	10	10	10	10	10	10	10
	m	3	3	3	3	3	3	3	3
Standard Piping Length	ft	25	25	25	25	25	25	25	25
	m	7.5	7.5	7.5	7.5	7.5	7.5	7.5	7.5
Max. Outdoor-Indoor Height Difference	ft	32.8	32.8	32.8	32.8	32.8	32.8	32.8	32.8
	m	10	10	10	10	10	10	10	10
Max. Piping Length w/ No Additional Refrigerant Charge	ft	25	25	25	25	25	25	25	25
	m	7.5	7.5	7.5	7.5	7.5	7.5	7.5	7.5
Max. Piping Length	ft	65.6	65.6	49.2	49.2	82	82	98.4	98.4
	m	20	20	15	15	25	25	30	30
Gas Pipe (size - connection type)	in	3/8	3/8	3/8	3/8	1/2	5/8	5/8	5/8
Liquid Pipe (size - connection type)	in	1/4	1/4	1/4	1/4	1/4	1/4	1/4	1/4

Table 5—Refrigerant Information DLFDAB / DLC DAR / DLFDHB / DLC DHR

System Size		9K	12K	9K	12K	18K	24K	30K	36K*	
Voltage		115/1/60	115/1/60	208/230-1-60	208/230-1-60	208/230-1-60	208/230-1-60	208/230-1-60	208/230-1-60	
Cooling Only	Refrigerant Type	--	R410A	R410A	R410A	R410A	R410A			
	Charge Amount	oz	26.5	31.8	24.7	30	35.3	56.45		
		kg	0.75	0.9	0.7	0.85	1	1.6		
	Additional Refrigerant Charge (between Standard – Max Piping Length)	oz/ft	0.161	0.161	0.161	0.161	0.161	0.161		
		g/m	15	15	15	15	15	15		
Heat Pump	Refrigerant Type	--	R410A	R410A	R410A	R410A	R410A	R410A	R410A	
	Charge Amount	oz	24.7	31.8	24.7	30	49.4	65.27	84.7	92
		kg	0.7	0.9	0.7	0.85	1.4	1.85	2.4	3
	Additional Refrigerant Charge (between Standard – Max Piping Length)	oz/ft	0.215	0.215	0.215	0.215	0.215	0.538	0.54	1
		g/m	20	20	20	20	20	50	50	50

NOTE: * Sizes 30 and 36 not available as Cooling Only.

WIRING

All wires must be sized per NEC (National Electrical Code) or CEC (Canadian Electrical Code) and local codes. Use the Electrical Data table MCA (minimum circuit amps) and MOCP (maximum over current protection) to correctly size the wires and the disconnect the fuse or breakers respectively.

Per the caution note, only Stranded copper conductors with a 600 volt rating and double insulated copper wire must be used.

NOTE: The use of BX cable is not recommended.

Recommended Connection Method for Power and Communication

Wiring – Power and Communication Wiring:

The main power is supplied to the outdoor unit. The field supplied 14/3 power/communication wiring from the outdoor unit to the indoor unit consists of four (4) wires and provides the power for the indoor unit.

Two wires are high voltage AC power, one is the communication wiring and the other is a ground wire.

Recommended Connection Method for Power and Communication Wiring (To minimize communication wiring interference)

PowerWiring:

The main power is supplied to the outdoor unit. The field supplied power wiring from the outdoor unit to the indoor unit consists of three (3) wires and provides the power for the indoor unit. Two wires are high voltage AC power and one is a ground wire.

To minimize a voltage drop, the factory recommended wire size is 14/2 stranded with a ground.

Communication Wiring:

A separate shielded stranded copper conductor only, with a minimum 600 volt rating and double insulated copper wire, must be used as the communication wire from the outdoor unit to the indoor unit.

Please use a separate shielded 16GA stranded control wire.

CAUTION

EQUIPMENT DAMAGE HAZARD

Failure to follow this caution may result in equipment damage or improper operation.

- Wires should be sized based on NEC and local codes.
- Use copper conductors only with a 600 volt rating and double insulated copper wire.

CAUTION

EQUIPMENT DAMAGE HAZARD

Failure to follow this caution may result in equipment damage or improper operation.

- Comply with local codes while running wire from indoor unit to outdoor unit.
- Every wire must be connected firmly. Loose wiring may cause a terminal to overheat or result in unit malfunction. A fire hazard may also exist. Ensure all wiring is tightly connected.
- No wire should touch refrigerant tubing, the compressor or any moving parts.
- Disconnecting means must be provided and must be located within sight and readily accessible from the air conditioner.
- Connecting the cable with conduit shall be routed through a hole in the conduit panel.

Table 6—Electrical Data

System Size		DLFCAB - DLCCAR / DLFCHB - DLCCHR							
		9K	12K	9K	12K	18K	24K	30K	36K
Voltage		115/1/60	115/1/60	208/230-1-60	208/230-1-60	208/230-1-60	208/230-1-60	208/230-1-60	208/230-1-60
MCA	A	12	17	9	9	16	20	20	24
MOCP	A	20	25	15	15	25	30	30	40

Table 7—Electrical Data

System Size		DLFDAB - DLCDAR / DLFHDB - DLCDHR							
		9K	12K	9K	12K	18K	24K	30K	36K
Voltage		115/1/60	115/1/60	208/230-1-60	208/230-1-60	208/230-1-60	208/230-1-60	208/230-1-60	208/230-1-60
MCA	A	17	20	9	9	16	15/16	20	24
MOCP	A	25	30	15	15	25	25	30	40

DIMENSIONS – INDOOR

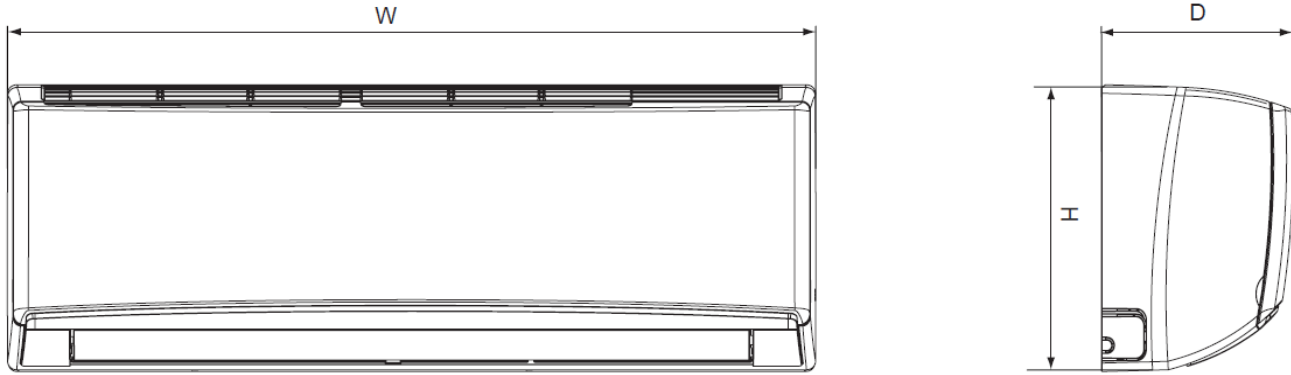

Fig. 1 – Indoor Unit Dimensions

Table 8—DLFCAB / DLCCAR / DLFCHB / DLCCHR

System Size		9K	12K	9K	12K	18K	24K	30K	36K
Voltage		115/1/60	115/1/60	208/230-1-60	208/230-1-60	208/230-1-60	208/230-1-60	208/230-1-60	208/230-1-60
Height (H)	in	11.4	11.4	11.4	11.4	11.8	12.8	12.8	12.8
Width (W)	in	33.3	33.3	33.3	33.3	38.2	42.4	53.1	53.1
Depth (D)	in	8.2	8.2	8.2	8.2	8.8	9.7	10	10
Weight-Net	lbs	23.2	23.2	22.1	22.1	27.6	34.2	41.9	41.9

Table 9—DLFDAB / DLC DAR / DLFDHB / DLC DHR

System Size		9K	12K	9K	12K	18K	24K	30K*	36K*
Voltage		115/1/60	115/1/60	208/230-1-60	208/230-1-60	208/230-1-60	208/230-1-60	208/230-1-60	208/230-1-60
Height (H)	in	10.8	11.4	10.8	11.4	11.8	12.8	12.8	12.8
Width (W)	in	31.1	33.3	31.1	33.3	38.2	42.4	53.1	53.1
Depth (D)	in	7.9	8.2	7.9	8.2	8.8	9.7	10	10
Weight-Net	lbs	19.8	22.1	19.8	23.2	29.8	37.5	41.9	41.9

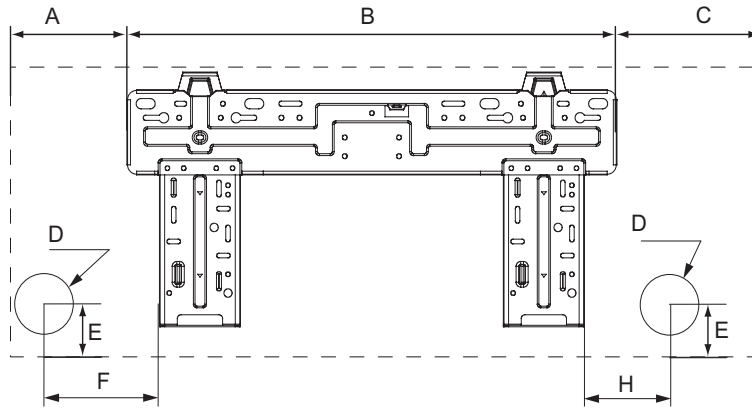

Fig. 2 – Indoor Mounting Plate

Table 10—DLFCAB / DLCCAR / DLFCHB / DLCCHR

System Size		9K	12K	9K	12K	18K	24K	30K	36K
Voltage		115/1/60	115/1/60	208/230-1-60	208/230-1-60	208/230-1-60	208/230-1-60	208/230-1-60	208/230-1-60
A	in	4.7	4.7	4.7	4.7	4.0	8.1	13.8	13.8
B	in	21.3	21.3	21.3	21.3	27.0	27.0	29.4	29.4
C	in	7.3	7.3	7.3	7.3	7.2	7.3	10.0	10.0
D	in	2.2	2.2	2.2	2.2	2.2	2.8	2.8	2.8
E	in	1.4	1.4	1.4	1.4	1.5	1.7	1.6	1.6
F	in	5.0	5.0	5.0	5.0	7.5	6.0	11.6	11.6
H	in	3.3	3.3	3.3	3.3	5.5	3.1	3.5	3.5

Table 11—DLFDAB / DLC DAR / DLFDHB / DLC DHR

System Size		9K	12K	9K	12K	18K	24K	30K*	36K*
Voltage		115/1/60	115/1/60	208/230-1-60	208/230-1-60	208/230-1-60	208/230-1-60	208/230-1-60	208/230-1-60
A	in	6.6	4.7	6.6	4.7	4.0	8.1	13.8	13.8
B	in	18.2	21.3	18.2	21.3	27.0	27.0	29.4	29.4
C	in	6.3	7.3	6.3	7.3	7.2	7.3	10.0	10.0
D	in	2.2	2.2	2.2	2.2	2.2	2.8	2.8	2.8
E	in	2.1	1.4	2.1	1.4	1.5	1.7	1.6	1.6
F	in	6.0	5.0	6.0	5.0	7.5	6.0	11.6	11.6
H	in	3.5	3.3	3.5	3.3	5.5	3.1	3.5	3.5

NOTE: * Sizes 30 and 36 not available as Cooling Only.

DIMENSIONS – OUTDOOR

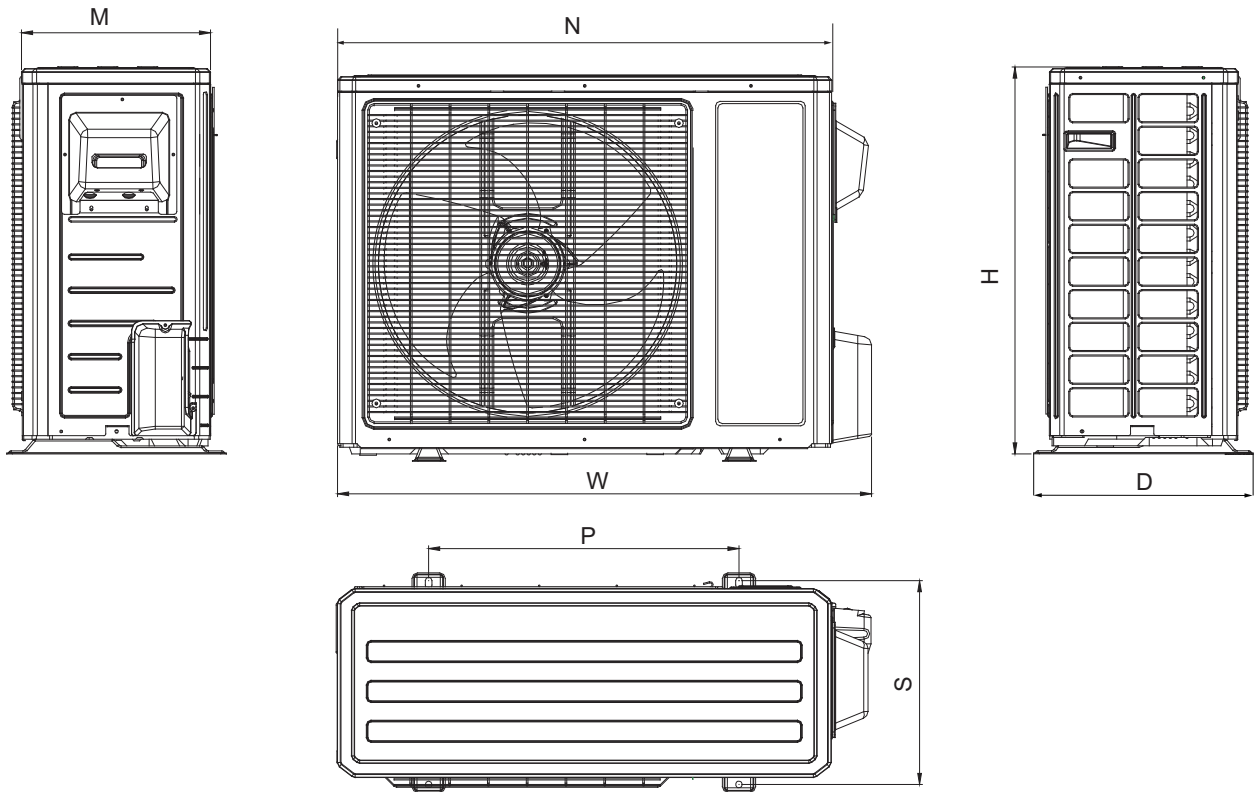

Fig. 3 – Outdoor Unit

Table 12—DLFCAB / DLCCAR / DLFCHB / DLCCHR

System Size		9K	12K	9K	12K	18K	24K	30K	36K
Voltage		115/1/60	115/1/60	208/230-1-60	208/230-1-60	208/230-1-60	208/230-1-60	208/230-1-60	208/230-1-60
Height (H)	in	21.3	23.3	21.3	23.3	27.6	31.1	31.1	31.1
Width (W)	in	33.4	33.4	33.4	33.4	37.6	38.6	38.6	38.6
Depth (D)	in	12.6	12.6	12.6	12.6	15.6	16.8	16.8	16.8
M	in	10.0	10.0	10.0	10.0	13.4	14.6	14.6	14.6
N	in	30.0	30.0	30.0	30.0	35.0	36.2	36.2	36.2
P	in	21.3	21.3	21.3	21.3	22.0	24.0	24.0	24.0
S	in	11.3	11.3	11.3	11.3	14.3	15.6	15.6	15.6
NET Weight Cooling Only	lbs	62.8	73.9	72.8	80.5	113.6	147.7	152.1	154.4
NET Weight Heat Pump	lbs	71.7	77.2	78.3	86	114.7	142.2	154.4	161

Table 13—DLFDAB / DLC DAR / DLF DHB / DLC DHR

System Size		9K	12K	9K	12K	18K	24K	30K*	36K*
Voltage		115/1/60	115/1/60	208/230-1-60	208/230-1-60	208/230-1-60	208/230-1-60	208/230-1-60	208/230-1-60
Height (H)	in	21.3	21.3	21.3	21.3	27.6	27.6		
Width (W)	in	30.6	30.6	30.6	30.6	37.6	37.6		
Depth (D)	in	12.6	12.6	12.6	12.6	15.6	15.6		
M	in	10.1	10.1	10.1	10.1	13.4	13.4	14.6	14.6
N	in	28.0	28.0	28.0	28.0	35.0	35.0	36.2	36.2
P	in	20.0	20.0	20.0	20.0	22.0	22.0	24.0	24.0
S	in	11.3	11.3	11.3	11.3	14.3	14.3	15.6	15.6
NET Weight Cooling Only	lbs	59.5	63.9	66.2	70.6	90.4	103.6		
NET Weight Heat Pump	lbs	62.8	67.3	65.0	69.5	95.9	110.3	154.4	161.0

NOTE: * Sizes 30 and 36 not available as Cooling Only.

CLEARANCES – INDOOR

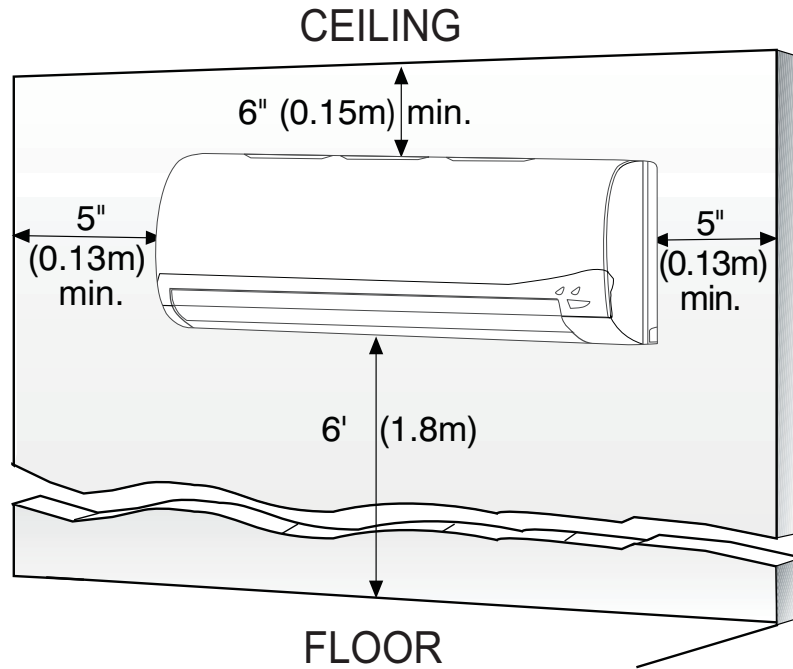

Fig. 4 – Indoor Unit Clearances

CLEARANCES – OUTDOOR

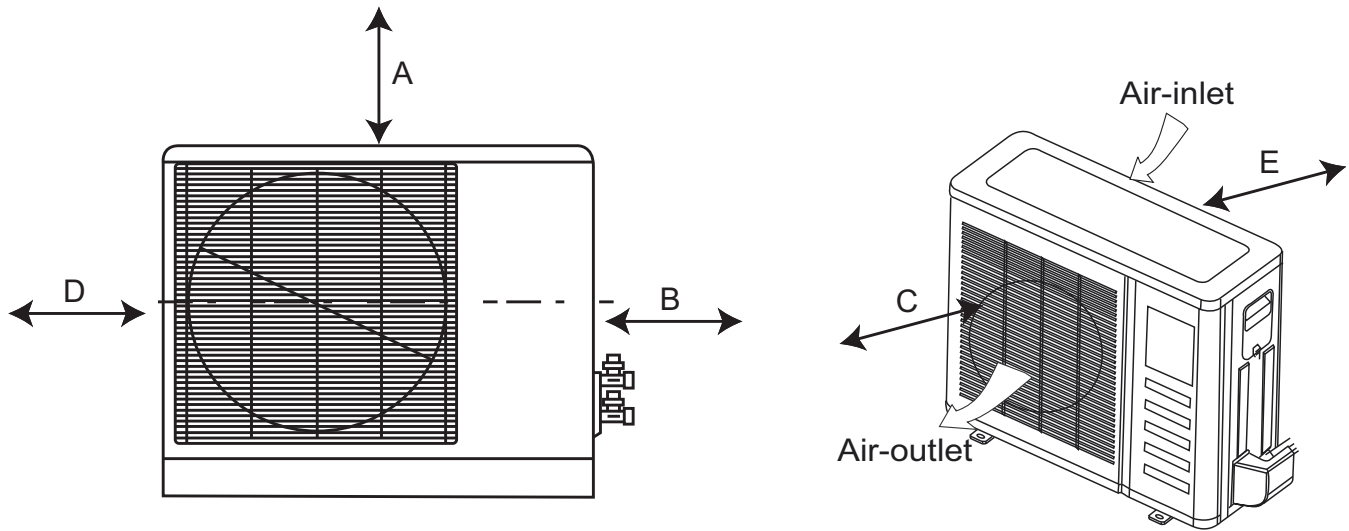

Fig. 5 – Outdoor Unit Clearances

Table 14—Outdoor Clearances

UNIT	Minimum Value in. (mm)
A	24 (609)
B	24 (609)
C	24 (609)
D	4 (101)
E	4 (101)

INSTALLATION GUIDE

Ideal installation locations include:

Indoor Unit

- A location where there are no obstacles near inlet and outlet area.
- A location which can bear the weight of indoor unit.
- Do not install indoor units near a direct source of heat such as direct sunlight or a heating appliance.
- A location which provides appropriate clearances as outlined in Fig. 4. Be sure to leave enough distance to allow access for routine maintenance. The installation site should be 72" or more above the floor.
- Select a place away from potential electronic interference.
- Select a place where the filter can be easily removed.

Outdoor Unit

- A location which is convenient to installation and not exposed to strong wind.
- A location which can bear the weight of outdoor unit and where the outdoor unit can be mounted in a level position.
- A location which provides appropriate clearances as outlined in Fig. 4.
- Do not install the indoor or outdoor units in a location with special environmental conditions.
- Make sure the outdoor unit is installed in accordance with the installation instructions and is convenient for maintenance and repair.
- See the refrigerant piping table for the maximum height difference between indoor and outdoor units and the maximum length of the connecting tubing.

INDOOR UNIT INSTALLATION

INSTALL MOUNTING PLATE

1. Carefully remove the mounting plate from the unit box.
2. The mounting plate should be located horizontally and level on the wall. All minimum spacings shown in Fig. 2.
3. If the wall is block, brick, concrete or similar material, drill .2" (5 mm) diameter holes and insert anchors for the appropriate mounting screws.
4. Attach the mounting plate to the wall.

DRILL HOLD IN WALL FOR INTERCONNECTING PIPING, DRAIN AND WIRING

Refrigerant Line Routing

The refrigerant lines may be routed in any of the four directions shown in Fig. 6.

For maximum serviceability, it is recommended to have refrigerant line flare connections and the drain connection on the outside of the wall that the fan coil is mounted on.

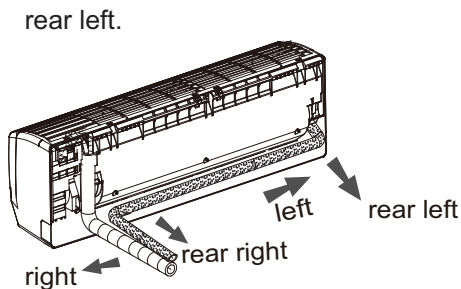

Fig. 6 – Refrigerant Line Routing

A12585

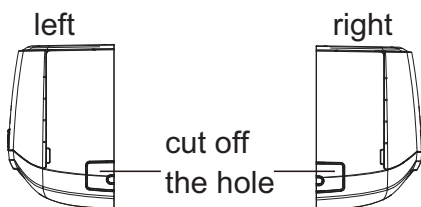

Fig. 7 – Refrigerant Line Routing

If piping is going through the back:

1. Determine pipe hole position using the mounting plate as a template. Drill pipe hole diameter per chart below. The outside pipe hole is 1/2-in. (13 mm) min. lower than inside pipe hole, so it slants slightly downward.

If piping is going to exit from the left rear, it is recommended to field-fabricate piping extensions to get the flare connections to the outside of the wall.

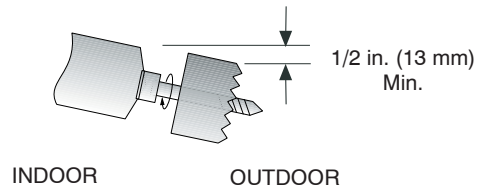

Fig. 8 – Drill Holes

A07371

Table 15—Hole Diameter

Model Size	Hole Diameter in. (mm)
9K, 12K, 18K, 24K	2.2 (56)
30K & 36K	2.75 (70)

If piping is going through the right or left side:

1. Use a small saw blade to carefully remove the corresponding plastic covering on side panel and drill the appropriate size hole where the pipe is going through the wall. See Fig. 14.
2. Remove knockout (see Fig. 7).

NOTE: If required, a condensate pump is available for the application.

OUTDOOR UNIT INSTALLATION

1. Use a rigid base to support unit in a level position.
2. Locate outdoor unit and connect piping and wiring.

⚠ CAUTION

EQUIPMENT DAMAGE HAZARD

Failure to follow this caution may result in equipment damage or improper operation.

Excessive torque can break flare nut depending on installation conditions.

Piping Connections to Outdoor Unit

IMPORTANT: Use refrigeration grade tubing ONLY. No other type of tubing may be used. Use of other types of tubing will void manufacturer's warranty.

Ensure there is enough piping to cover the required length between the outdoor and indoor unit. Only use piping suitable for high side pressure for both high side and low side connections.

Piping Guide:

- Do not open service valves or remove protective caps from tubing ends until all the connections are made.
- Bend tubing with bending tools to avoid kinks and flat spots.
- Keep the tubing free of dirt, sand, moisture, and other contaminants to avoid damaging the refrigerant system.
- Avoid sags in the suction line to prevent the formation of oil traps. Insulate each tube with minimum 3/8-in. (10 mm) wall thermal pipe insulation. Inserting the tubing into the insulation before making the connections saves time and improves installation quality.
 1. Remove service valve cover if provided with unit.
 2. Cut tubing with tubing cutter.
 3. Install correct size flare nut onto tubing and make flare connection.
 4. Apply a small amount of refrigerant oil to the flare connection on the tubing.
 5. Properly align tubing in with service valve.
 6. Tighten flare nut and finish installation using two wrenches as shown in Fig. 9.

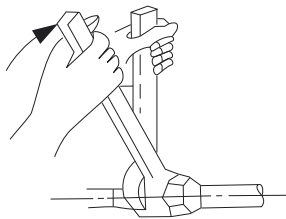

A07354

Fig. 9 – Tighten Flare Nut

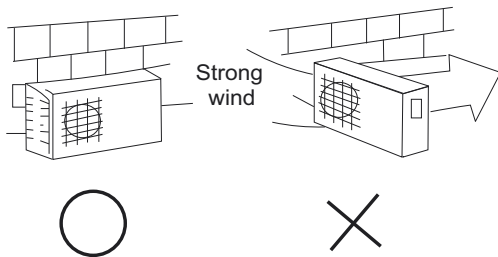

A07350

Fig. 10 – High Wind Installation

Outdoor Unit Wiring Connections

1. Mount outdoor power disconnect.
2. Run power wiring from main box to disconnect per NEC and local codes. Set outdoor unit in place.
3. Remove field wiring cover from unit by removing screws.
4. Connect conduit to the conduit panel (see Fig. 11).
5. Properly connect both power supply and control lines to terminal block per the connection diagram.
6. Ground unit in accordance with NEC and local electrical codes.
7. Use lock nuts to secure conduit.
8. Reinstall field wiring cover.

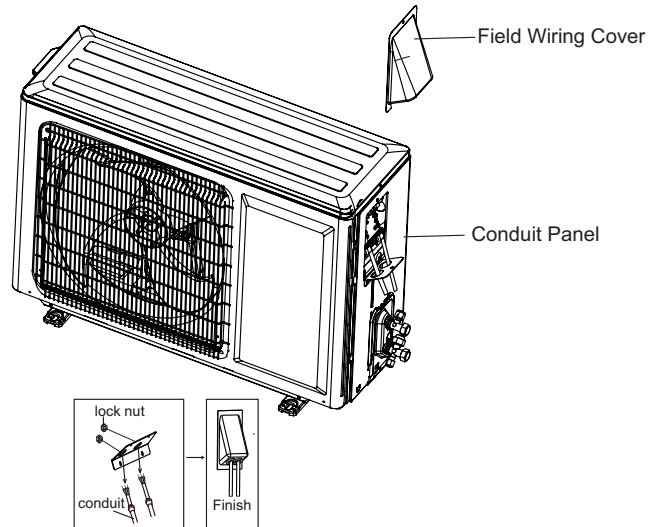

A12539

Fig. 11 – Field Wiring

⚠ **CAUTION**

EQUIPMENT DAMAGE HAZARD

Failure to follow this caution may result in equipment damage or improper operation.

- Be sure to comply with local codes while running wire from indoor unit to outdoor unit.
- Every wire must be connected firmly. Loose wiring may cause terminal to overheat or result in unit malfunction. A fire hazard may also exist. Therefore, be sure all wiring is tightly connected.
- No wire should be allowed to touch refrigerant tubing, compressor or any moving parts.
- Disconnecting means must be provided and shall be located within sight and readily accessible from the air conditioner.
- Connecting cable with conduit shall be routed through hole in the conduit panel.

INSTALL ALL POWER, INTERCONNECTING WIRING, AND PIPING TO INDOOR UNIT

1. Run interconnecting piping and wiring from outdoor unit to indoor unit.
2. Pass interconnecting cable through hole in wall (outside to inside).
3. Lift indoor unit into position and route piping and drain through hole in wall (inside to outside). Fit interconnecting wiring into back side of indoor unit.
4. Hang indoor unit on upper hooks of wall mounting plate (as shown in Fig. 12 and Fig. 15).

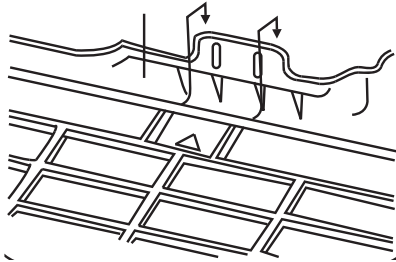

Fig. 12 – Hanging Indoor Unit

A08283

5. Open front cover of indoor unit and remove field wiring terminal block cover (see Fig. 13).

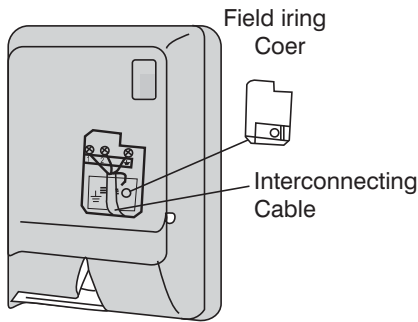

Fig. 13 – Field Wiring Cover

A08279

6. Pull interconnecting wire up from back of indoor unit and position in close to the terminal block on indoor unit.
7. Push bottom of indoor unit onto mounting plate to complete wall mount.
8. Connect wiring from outdoor unit per connection diagram (see Fig. 21).

NOTE: Polarity of power wires must match original connection on outdoor unit.

9. Replace field wiring cover and close front cover of indoor unit.
10. Connect refrigerant piping and drain line outside of indoor unit. Refer to Fig. 9 for proper installation of flare connections. Complete pipe insulation at flare connection then fasten piping and wiring to the wall as required. Completely seal the hole in the wall.

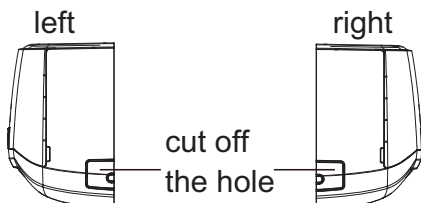

Fig. 14 – Remove Knockouts

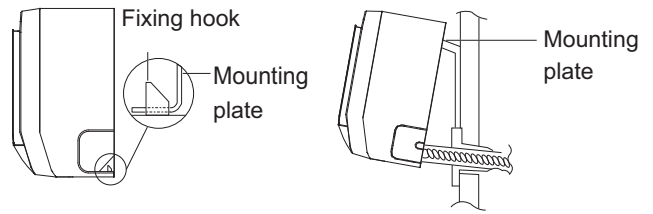

Fig. 15 – Hang Indoor Unit

A12408

⚠ CAUTION

UNIT DAMAGE HAZARD

Failure to follow this caution may result in equipment damage or improper operation.

Never use the system compressor as a vacuum pump.

Refrigerant tubes and indoor coil should be evacuated using the recommended deep vacuum method of 500 microns. The alternate triple evacuation method may be used if the procedure outlined below is followed. Always break a vacuum with dry nitrogen.

SYSTEM VACUUM AND CHARGE

Using Vacuum Pump

1. Completely tighten flare nuts A, B, C, D, connect manifold gage charge hose to a charge port of the low side service valve (see Fig. 16.)
2. Connect charge hose to vacuum pump.
3. Fully open the low side of manifold gage (see Fig. 17).
4. Start vacuum pump
5. Evacuate using either deep vacuum or triple evacuation method.
6. After evacuation is complete, fully close the low side of manifold gage and stop operation of vacuum pump.
7. The factory charge contained in the outdoor unit is good for up to 25 ft. (8 m) of line length. For refrigerant lines longer than 25 ft (8 m), add 0.2 oz. per foot of extra piping up to the maximum allowable length.
8. Disconnect charge hose from charge connection of the low side service valve.
9. Fully open service valves B and A.
10. Securely tighten caps of service valves.

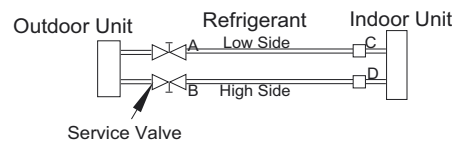

Fig. 16 – Service Valve

A07360

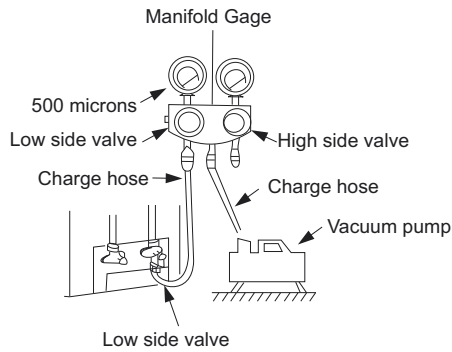

Fig. 17 – Manifold

A07361

Deep Vacuum Method

The deep vacuum method requires a vacuum pump capable of pulling a vacuum of 500 microns and a vacuum gage capable of accurately measuring this vacuum depth. The deep vacuum method is the most positive way of assuring a system is free of air and liquid water. (See Fig. 18)

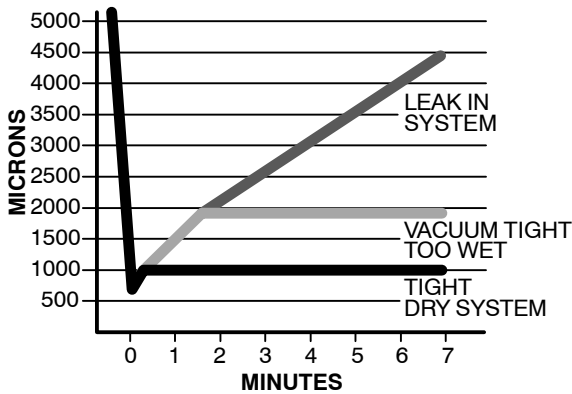

Fig. 18 – Deep Vacuum Graph

A95424

Triple Evacuation Method

The triple evacuation method should only be used when vacuum pump is only capable of pumping down to 28 in. of mercury vacuum and system does not contain any liquid water.

Refer to Fig. 19 and proceed as follows:

1. Pump system down to 28 in. of mercury and allow pump to continue operating for an additional 15 minutes.
2. Close service valves and shut off vacuum pump.
3. Connect a nitrogen cylinder and regulator to system and open until system pressure is 2 psig.
4. Close service valve and allow system to stand for 1 hr. During this time, dry nitrogen will be able to diffuse throughout the system absorbing moisture.
5. Repeat this procedure as indicated in Fig. 19. The system is then free of any contaminants and water vapor.

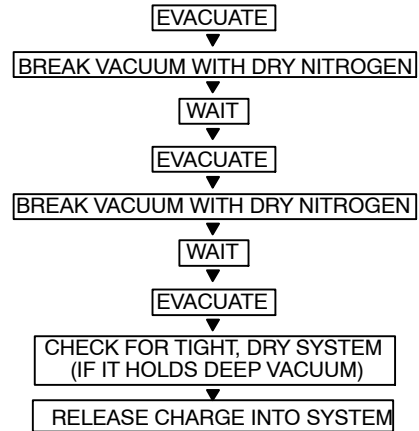

Fig. 19 – Triple Evacuation Method

A95425

Final Tubing Check

IMPORTANT: Check to be certain factory tubing on both indoor and outdoor unit has not shifted during shipment. Ensure tubes are not rubbing against each other or any sheet metal. Pay close attention to feeder tubes, making sure wire ties on feeder tubes are secure and tight.

START-UP

Test Operation

Perform test operation after completing gas leak and electrical safety check.

1. Push the "ON/OFF" button on Remote Control to begin testing.

NOTE: A protection feature prevents the air conditioner from being activated for approximately 3 minutes.

2. Push MODE button, select COOLING, HEATING, FAN mode to check if all functions work correctly.

SYSTEM CHECKS

1. Conceal the tubing where possible.
2. Make sure that the drain tube slopes downward along its entire length.
3. Ensure all tubing and connections are properly insulated.
4. Fasten tubes to the outside wall, when possible.
5. Seal the hole through which the cables and tubing pass.

INDOOR UNIT

1. Do all Remote Control buttons function properly?
2. Do the display panel lights work properly?
3. Does the air deflection louver function properly?
4. Does the drain work?

OUTDOOR UNIT

1. Are there unusual noises or vibrations during operation?

Explain Following Items To Customer With The Aid Of The Owner's Manual:

1. How to turn air conditioner on and off; selecting COOLING, HEATING and other operating modes; setting a desired temperature; setting the timer to automatically start and stop air conditioner operation; and all other features of the Remote Control and display panel.
2. How to remove and clean the air filter.
3. How to set air deflection louver.
4. Explain care and maintenance.
5. Present the Owner's Manual and installation instructions to customer.

INSTALLATION AND MAINTENANCE OF FILTER

1. Grasp the front panel by its two ends and lift the panel and then remove the air filter.
2. Install a clean air filter along the arrow direction and close the panel.

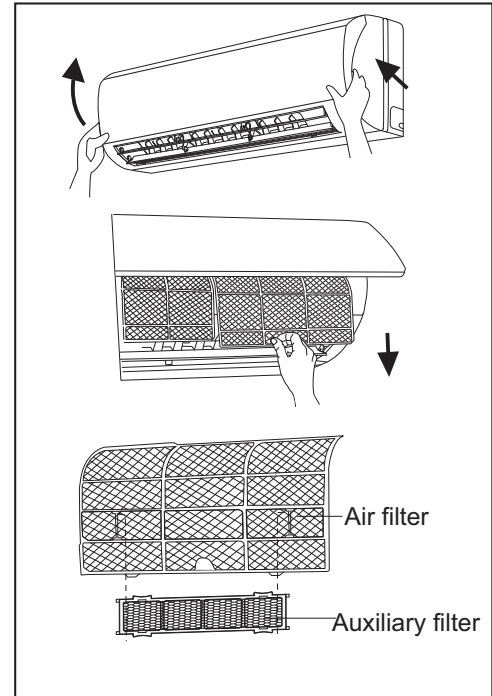

Fig. 20 – Install Air Filter

A12541

WIRING DIAGRAMS

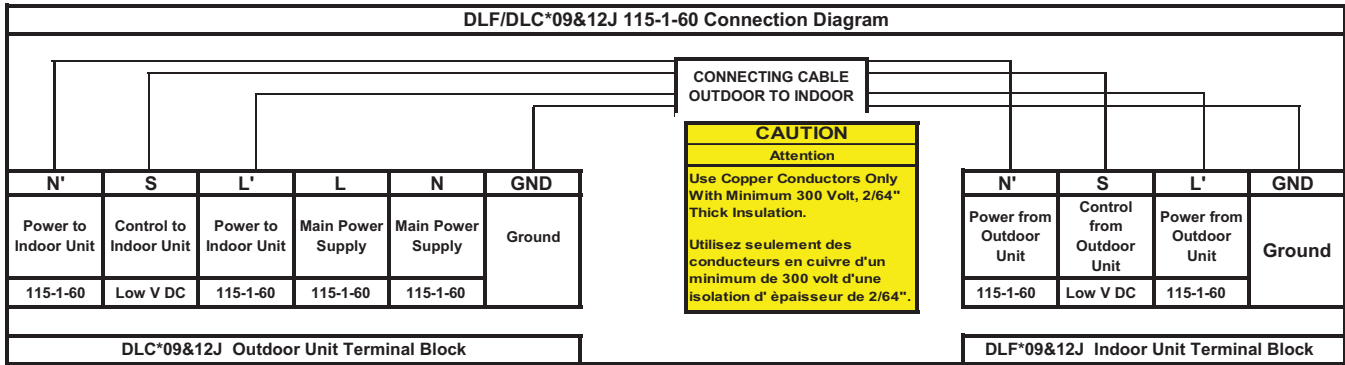

Fig. 21 – 09K & 12K 115V Unit Wiring Diagrams

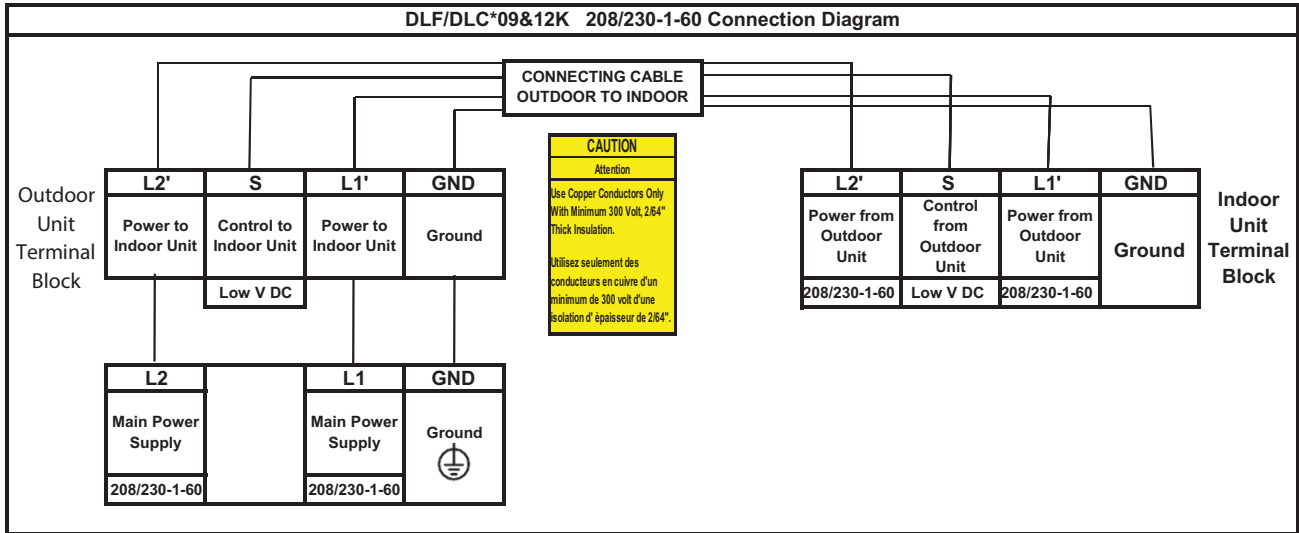

Fig. 22 – 09K & 12K 208/230V Unit Wiring Diagrams

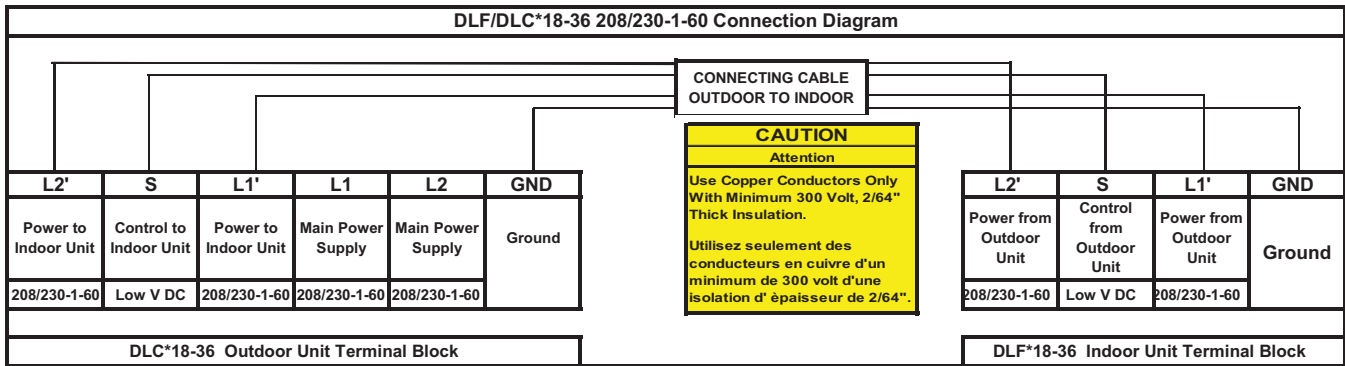

Fig. 23 – 18K & 36K 208/230V Unit Wiring Diagrams

NOTE: Polarity of power wires must match original connection on outdoor unit.

TROUBLESHOOTING

This unit has on-board diagnostics. Error codes appear on the LED display on the front panel of the indoor unit in place of the temperature display. Error codes are also displayed on the outdoor unit microprocessor board with colored LED lights. The table below explains the error codes for both units.

Table 16—Diagnostic Codes

Malfunction	Display of Indoor Unit	Display of lamp (the times of blinking)					
		Indoor			Outdoor		
		R	C	H	Y	R	G
Anti-freezing protection	E2	2			3		
Block or Low pressure of refrigerant system	E3	3				9	
Compressor exhaust high temperature protection	E4	4			7		
AC over-current protection	E5	5			5		
Communication failure between indoor unit and outdoor unit	E6	6					O/U
Anti-high temperature protection	E8	8			6		
	H4			4	6		
No feedback of indoor fan motor	H6	11					
Jumper cap malfunction protection	C5	15					
Indoor unit and outdoor unit doesn't match	LP	19			16		
Outdoor DC fan motor malfunction	L3	23				14	
Power protection	L9	20			9		
Gathering refrigerant	Fo	1	1				
Indoor ambient sensor open or short circuit	F1		1				
Indoor tube sensor open or short circuit	F2		2				
Outdoor ambient sensor open or short circuit	F3		3			6	
Outdoor tube sensor open or short circuit	F4		4			5	
Exhaust sensor open or short circuit	F5		5			7	
Overload limit / drop frequency	F6		6			3	
Over current limit / drop frequency	F8		8			1	
High exhaust temperature limit / drop frequency	F9		9			2	
Refrigerant leakage protection	F0		10			9	
Anti-freezing limit / drop frequency	FH		2	2		4	
Defrosting	H1			1	2		
Compressor overload protection	H3			3	8		
IPM protection	H5			5	4		
Module temperature is too high	H5			5	10		
PFC protection	HC			6	14		
Loading EEPROM malfunction	EE			15	11		
High PN voltage protection	PH		11		13		
Low PN voltage protection	PL			21	12		
4-way valve reversal abnormal	U7		20				
DRED1 / DRED2 / DRED3	d1/d2/d3						
Compressor Min frequency in test state	P0						
Compressor rated frequency in test state	P1						
Compressor maximum frequency in test state	P2						
Compressor intermediate frequency in test state	P3						
Compressor is running(normal)					1		
The temperature for turning on the unit is reached (normal)						8	
Frequency limiting (module temperature)	EU		6	6		11	
Frequency limiting (power)	LU		24			13	

R (Indoor) -- Running

C -- Cooling

Y -- Yellow

R (Outdoor) -- Red

G -- Green

O/U -- OFF or Unblink. The display difference between Fo and F0 is 'o' is the bottom part of Fig. 8

