

**CADWELD®**

**CADWELD® PLUS**

Leading Technologies In Exothermic Welding

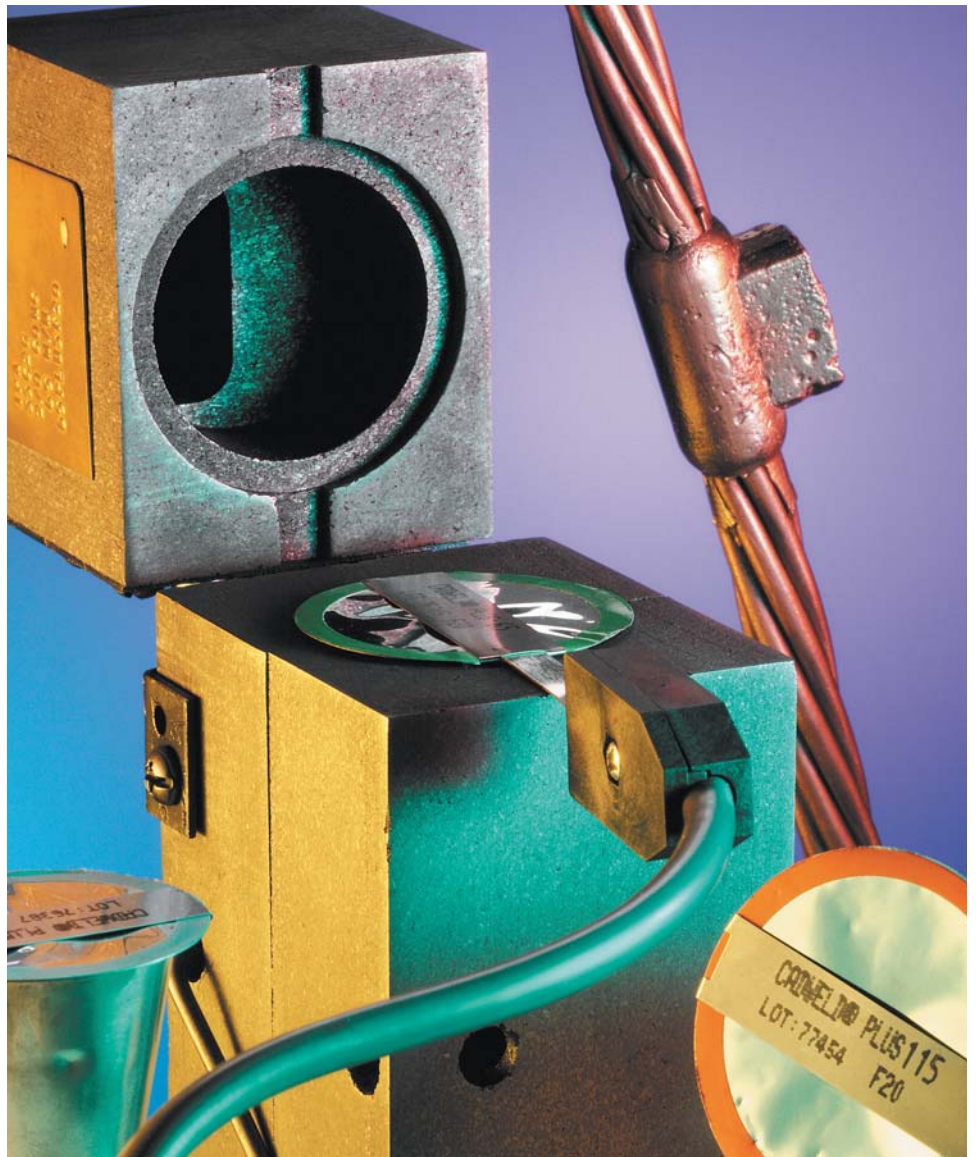

**ERICO®**

CADWELD® PLUS connections offer all the benefits of conventional CADWELD® connections:

- Withstand repeated fault currents without failing during operation
- Exceed requirements of "IEEE® Std 837- Std. for Qualifying Permanent Connections Used In Substation Grounding"
- Join copper to copper, copper to galvanized or plain steel, copper to copper clad steel, copper to bronze/ brass/stainless steel, steel to steel, etc.
- Current carrying capacity equal to or greater than that of the conductor
- Permanent, molecular bond that will not loosen or corrode, resulting in a connection with a lifetime equal to that of the installation
- No external power or heat source required
- Quality Assurance Inspection is easy and visual
- Minimal installation training required



The CADWELD molecular bond will last the lifetime of the conductors.

# CADWELD® PLUS

The ultimate welded connection that will never loosen, corrode or increase in resistance just got **BETTER.**

CADWELD PLUS is the latest advancement in the continuing evolution of ERICO's exothermic products. Since it's development in 1938, CADWELD electrical connections have become recognized as the ultimate connection for rail, cathodic, power and grounding applications. ERICO® has established itself as the worldwide connections leader. CADWELD PLUS continues this tradition of technical leadership.

The revolutionary CADWELD PLUS System is a simplified method of performing exothermically welded electrical connections. The CADWELD PLUS integrated weld metal package has streamlined the installation process by eliminating ignition materials – reducing set up time.

The tamper proof, integrated weld metal package consists of a steel cup containing CADWELD patented weld metal alloys and ignition source. This new weld metal package is designed for use in all standard CADWELD molds including CADWELD® MULTI. Once placed in the CADWELD mold, the weld metal is electronically ignited using a simple battery-powered control unit with six (6) foot lead.

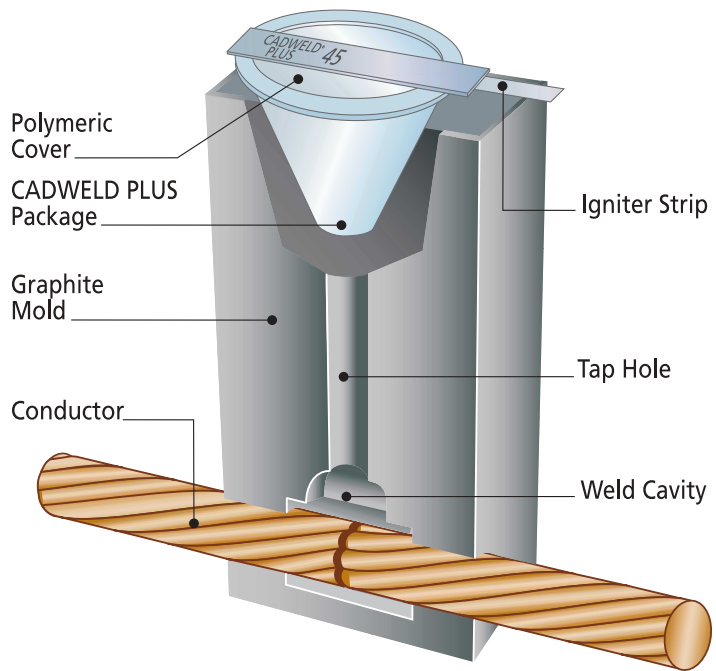

## CADWELD® PLUS

### Feature

*Integrated Weld Metal Package*

*Color Coded Weld Metal*

*Electronic Control Unit*

*Six Foot Control Unit Lead*

### Benefits

- Simplifies training and set up
- Saves labor
- Simplifies cleaning
- Reduces risk of misapplication
- Simple visual verification of correct weld metal size
- No starting material required
- Easy ignition
- Increased flexibility in hard to reach areas

## The CADWELD® PLUS system:

**CADWELD®**

*Proven Safety and  
Proven Performance  
with No Equal*

- Consists of a tamper proof, disposable, moisture-resistant weld metal cup. The weld metal, disk and ignition source are incorporated into the self-contained package
- Virtually unlimited shelf life
- Completes welds at distances of up to 6 ft/1.8 meters (up to 15 ft/4.6 meters with optional lead)
- Requires minimum components – no starting material, no disks, no flint igniters
- Easy to handle, store and transport – by air, land or sea in unlimited quantities
- Reduces installation time by 20%
- Has color-coded weld metal containers – by size and alloy type – for easy identification
- Has electronic ignition with a CE/UL battery powered controller box that is designed for 600 connections with one set of 8 standard AA batteries (included) – requiring no special batteries or chargers
- Designed for use in standard CADWELD® molds including CADWELD® MULTI

## Installation Is Easy!

### 4 Simple Steps For Permanently Welded Electrical Connections



*Insert CADWELD PLUS package into mold (may require use of a cover/baffle)*



*Attach control unit termination clip to ignition strip*



*Press and hold control unit switch and wait for the ignition*



*Open the mold and remove the expended steel cup – no special disposal required*

CADWELD PLUS Control Unit initiates the reaction of the metal crucible. The standard unit includes a 6-foot (1.8 meter) high temperature control unit lead. The lead attaches to the ignition strip using a custom made, purpose-designed termination clip.

After the termination clip is installed on the ignition strip, the installer pushes and holds the ignition button to start a charging and discharging sequence. Within a few seconds the control unit sends a predetermined voltage to the ignition strip and the reaction is initiated.

# CADWELD® PLUS

## Color Coded Containers

CADWELD PLUS uses the following color codes and general product nomenclature:



### CADWELD PLUS for Grounding Applications

CADWELD PLUS Part Number	European Article Number	Size Identification Ring Color	Traditional Welding Material Part Number (Clear Cap)
15PLUSF20	165700	Black	15
25PLUSF20	165701	Red	25
32PLUSF20	165702	White	32
45PLUSF20	165703	Light Blue	45
65PLUSF20	165704	Dark Green	65
90PLUSF20	165705	Gray	90
115PLUSF20	165706	Orange	115
150PLUSF20	165707	Dark Blue	150
200PLUSF20	165708	Yellow	200
250PLUSF20	165709	Purple	250
300PLUSF20	165710	Light Green	use 2 x 150
400PLUSF20	165711	Brown	use 2 x 200
500PLUSF20	165712	Light Brown	500

### CADWELD PLUS for Cathodic Applications

CADWELD PLUS Part Number	European Article Number	Size Identification Ring Color	Traditional Welding Material Part Number (Green Cap)
CA15PLUSF33	165713	Black	CA15/CA15S
CA25PLUSF33	165714	Red	CA25
CA32PLUSF33	165715	White	CA32
CA45PLUSF33	165716	Light Blue	CA45
CA65PLUSF33	165717	Dark Green	CA65

CADWELD PLUS Part Number	European Article Number	Size Identification Ring Color	Traditional Welding Material Part Number (Orange Cap)
CA25PLUSXF19	165722	Red	CA25XF19
CA32PLUSXF19	165723	White	CA32XF19
CA45PLUSXF19	165724	Light Blue	CA45XF19
CA65PLUSXF19	165725	Dark Green	CA65XF19

### CADWELD PLUS for Cast Iron Applications

CADWELD PLUS Part Number	European Article Number	Size Identification Ring Color	Traditional Welding Material Part Number (Orange Cap)
25PLUSXF19	165718	Red	25XF19
32PLUSXF19	165719	White	32XF19
45PLUSXF19	165720	Light Blue	45XF19
65PLUSXF19	165721	Dark Green	65XF19

Gram weight PLUS weld metal type i.e. 45PLUSF20

### Accessories

Part Number	European Article Number	Description
PLUSCU	165738	CADWELD PLUS Control Unit
PLUSCU15L	165745	CADWELD PLUS Control Unit with 15 ft. (4.6 meters) Lead
PLUSCULD	165739	CONTROL UNIT Replacement Lead 6 ft. (1.8 meters)
PLUSCULD15	165746	CONTROL UNIT Replacement Lead 15 ft. (4.6 meters)
MC2X2KIT	165740	Kit, Baffle Cover, Graphite - 2" X 2" Mold
MC25X3KIT	165744	Kit, Baffle Cover, Graphite - 2½" X 3" Mold
MC3X3KIT	165741	Kit, Baffle Cover, Graphite - 3" X 3" Mold
MC4X4KIT	165742	Kit, Baffle Cover, Graphite - 4" X 4" Mold



PLUSCU

Baffle Cover Kit

PLUSCULD

CADWELD PLUS Patent Numbers 6,553,911 6,835,910 6,703,578

**WARNING**  
ERICO products shall be used only as illustrated and recommended in the product instruction sheets (additional instruction sheets are available at [www.erico.com](http://www.erico.com)). Misuse or misapplication may cause failure resulting in possible property damage or bodily injury.

**WARRANTY; CLAIMS; EXCLUSIVE REMEDY**  
ERICO products are warranted to be free from defects in material and workmanship at the time of shipment. NO OTHER WARRANTY, WHETHER EXPRESS OR IMPLIED (INCLUDING ANY WARRANTY OF MERCHANTABILITY OR FITNESS FOR A PARTICULAR PURPOSE), SHALL EXIST IN CONNECTION WITH THE SALE OR USE OF ANY ERICO PRODUCTS. Claims for errors, shortages, defects or nonconformities ascertainable upon inspection must be made in writing within 5 days after the Buyer's receipt of products. All other claims must be made in writing to ERICO within 6 months from the date of shipment or transport. Products claimed nonconforming or defective must, upon ERICO's prior written approval in accordance with its standard terms and procedures governing returns, promptly be returned to ERICO for inspection. Claims not made as provided above and within the applicable time period will be barred. ERICO shall in no event be responsible if the products have not been stored or used in accordance with its specifications and recommended procedures. ERICO will, at its option, either repair or replace nonconforming or defective products for which it is responsible or return the purchase price to Buyer. THE FOREGOING STATES BUYER'S EXCLUSIVE REMEDY FOR ANY BREACH OF ERICO WARRANTY AND FOR ANY CLAIM, WHETHER SOUNDING IN CONTRACT, TORT OR NEGLIGENCE, FOR LOSS OR INJURY CAUSED BY THE SALE OR USE OF ANY PRODUCT.

**LIMITATION OF LIABILITY**  
ERICO excludes all liability except that is directly attributable to the willful or gross negligence of ERICO's employees. Should ERICO be held liable its liability shall in no event exceed the total purchase price under the contract. ERICO SHALL IN NO EVENT BE RESPONSIBLE FOR ANY LOSS OF BUSINESS OR PROFITS, DOWNTIME OR DELAY, LABOR, REPAIR OR MATERIAL COSTS OR ANY SIMILAR OR DISSIMILAR CONSEQUENTIAL LOSS OR DAMAGE INCURRED BY BUYER.

IEEE is a registered trademark of The Institute of Electrical and Electronics Engineers, Incorporated.

Copyright ©2005 ERICO International Corporation. All rights reserved.

CADDY, CADWELD, CRITEC, ERICO, ERITECH, ERIFLEX, and LENTON are registered trademarks of ERICO International Corporation.