

# Ball Valve Hose Cocks

**TECK<sup>®</sup>**  
COMMERCIAL

**DELTA<sup>®</sup>**

## Features:

- Floating ball design
- Vacuum valves supplied with a corrosion resistant finish ball and viton O-rings for improved durability
- Vandal resistant handle – obvious on/off positions
- Check valve to prevent contamination of service lines and valve sealing surfaces
- Vandal resistant 10 serration 3.2 mm (1/8") I.D. nozzle. Removable with flat on one side
- Factory tested to 125 psi
- Meets ADA prescribed 5 lb. force pressure requirement
- Life cycle tested to 100,000 cycles
- Turret mounted units include vandal resistant locking pins to prevent damage to mounting surface (can be removed in field if not required)

## Valve Only

- W6200**  
Ball valve hose cock, floating ball-type design, 3/8" M.I.P. inlet, **removable universal 10 serration vandal resistant nozzle**, with 3.2 mm (1/8") outlet, forged brass vandal resistant handle, O-ring seals, check piston located in nozzle (with exception of vacuum service).  
Coloured index button to suit desired service.

## Wallmount Valves

- W6270**  
Ball valve hose cock, **1 valve** with flange, **with shank**, locknut, lockwasher, coupling nut and 1/4" I.P. tailpiece.

## Deckmount Valves

- W6210**  
Deckmount turret with **single ball valve hose cock**, complete with vandal resistant locking pins, shank, locknut, lockwasher, coupling nut and 1/4" I.P. tailpiece.
- W6220**  
Deckmount turret with **2 ball valve hose cocks mounted at 90 degrees**, complete with vandal resistant locking pins, shank, locknut, lockwasher, coupling nut and 1/4" I.P. tailpiece.
- W6225**  
Deckmount turret with **2 ball valve hose cocks mounted at 180 degrees**, complete with vandal resistant locking pins, shank, locknut, lockwasher, coupling nut and 1/4" I.P. tailpiece.



**Note:** Delta Faucet offers a 10 year warranty on all ball valves – Best in the industry – every ball valve carries its date of manufacture on the underside of the body.

### Ball Valve Testing

- (1) Natural Gas/Propane – Tested at 1/2 psi & 125 psi
- (2) Vacuum – Tested for vacuum use only
- (3) Non-Gas (i.e., Air, Nitrogen) – Tested at 125 psi only

Y = Yes N = No Y3 = Yes, up to 60 psi

Relatively Coarse Control (1/4 turn to full open)

\*Not for potable water

VALVE TYPE	SERVICE									
	Natural Gas/Propane	Vacuum	Air	Nitrogen	Argon	Oxygen	Steam	Cold Water*	Hot Water	Other Services
Ball Valves	Y	Y	Y	Y	Y	N	N	Y3	N	Check with Technical Service

Refer to [www.specselect.com](http://www.specselect.com) for individual models.

Note: Use this page front and back as a product submittal sheet.

Delta reserves the right (1) to make changes in specifications and materials, and (2) to change or discontinue models, both without notice or obligation. Dimensions are for reference only. See current full-line price book or [www.specselect.com](http://www.specselect.com) for finish options and product availability.

DSP-W6200 Rev. E

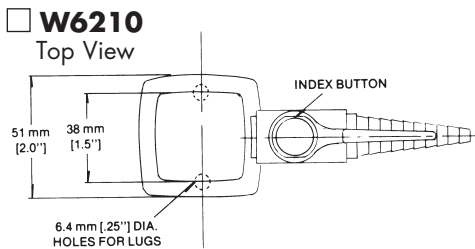
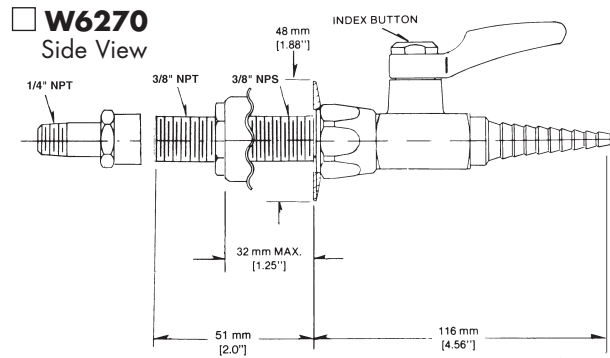
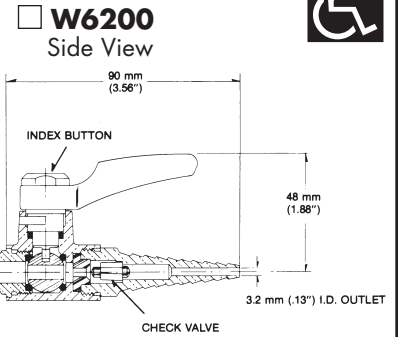
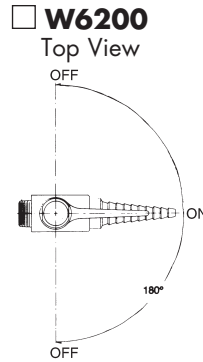
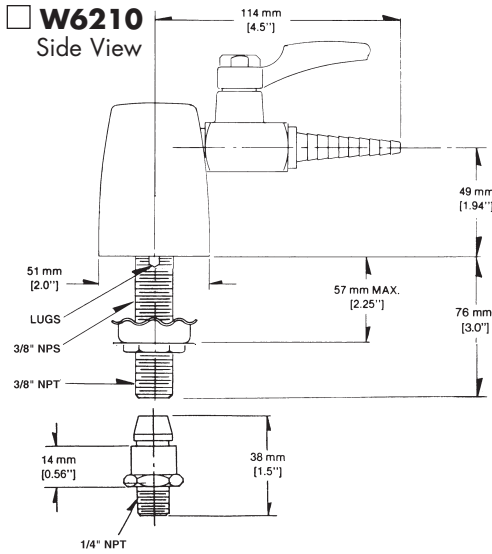

**Water service products not for potable water**

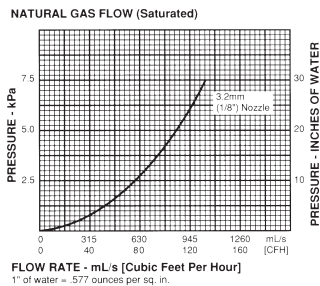
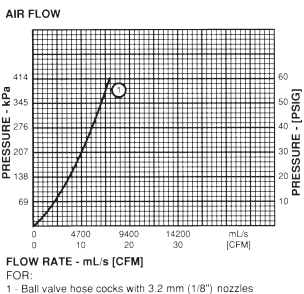

## Field Conversion

1. Natural Gas/Propane valves should only be used for Natural Gas/Propane.
2. Vacuum valves should only be used for Vacuum.
3. Non-Gas valves (i.e. Air, Nitrogen etc.) can be converted to any "Y" service **except** Natural Gas/Propane or Vacuum.

## Approvals and Standards Met:

CSA approved and tested to ANSI Z21.15/CSA 9.1 for use with natural, manufactured and mixed gas, liquefied petroleum (LP) gases and LP gas-air mixtures with a maximum rated pressure of 0.5 psi.

Indicates compliance to ICC/ANSI A117.1.

**Note:** To calculate flow rate in BTU/hr:

- (i) Using pressure at inlet of valve find flow rate in cubic feet per hour from chart (left).
- (ii) Multiply BTU rating of gas service (BTU/ft<sup>3</sup>) by flow in CFH found from (i) above, to give flow in BTU/hr.

Note: Measurements may vary  $\pm$  6mm (0.25")

Refer to [www.specselect.com](http://www.specselect.com) for individual models.

Note: Use this page front and back as a product submittal sheet.