

Pump Specification

LSG200-Series (Single-Stage) LSGX200-Series (2-Stage)

Omnivore® 2 HP Submersible Grinder Pumps

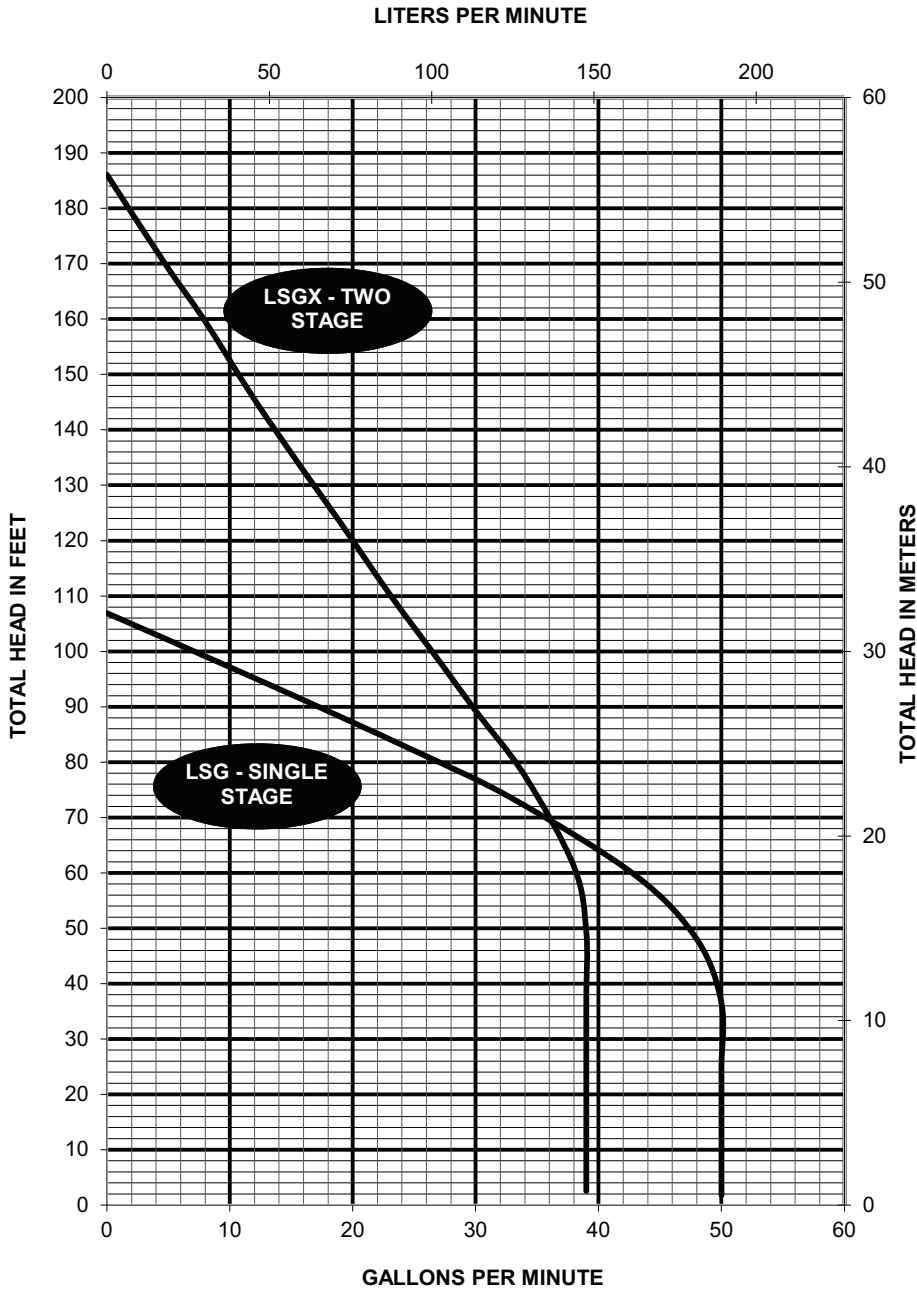
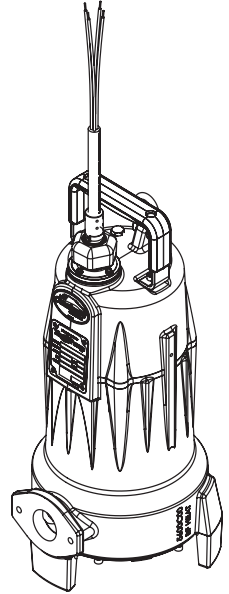

LSG/LSGX-Series Dimensional Data

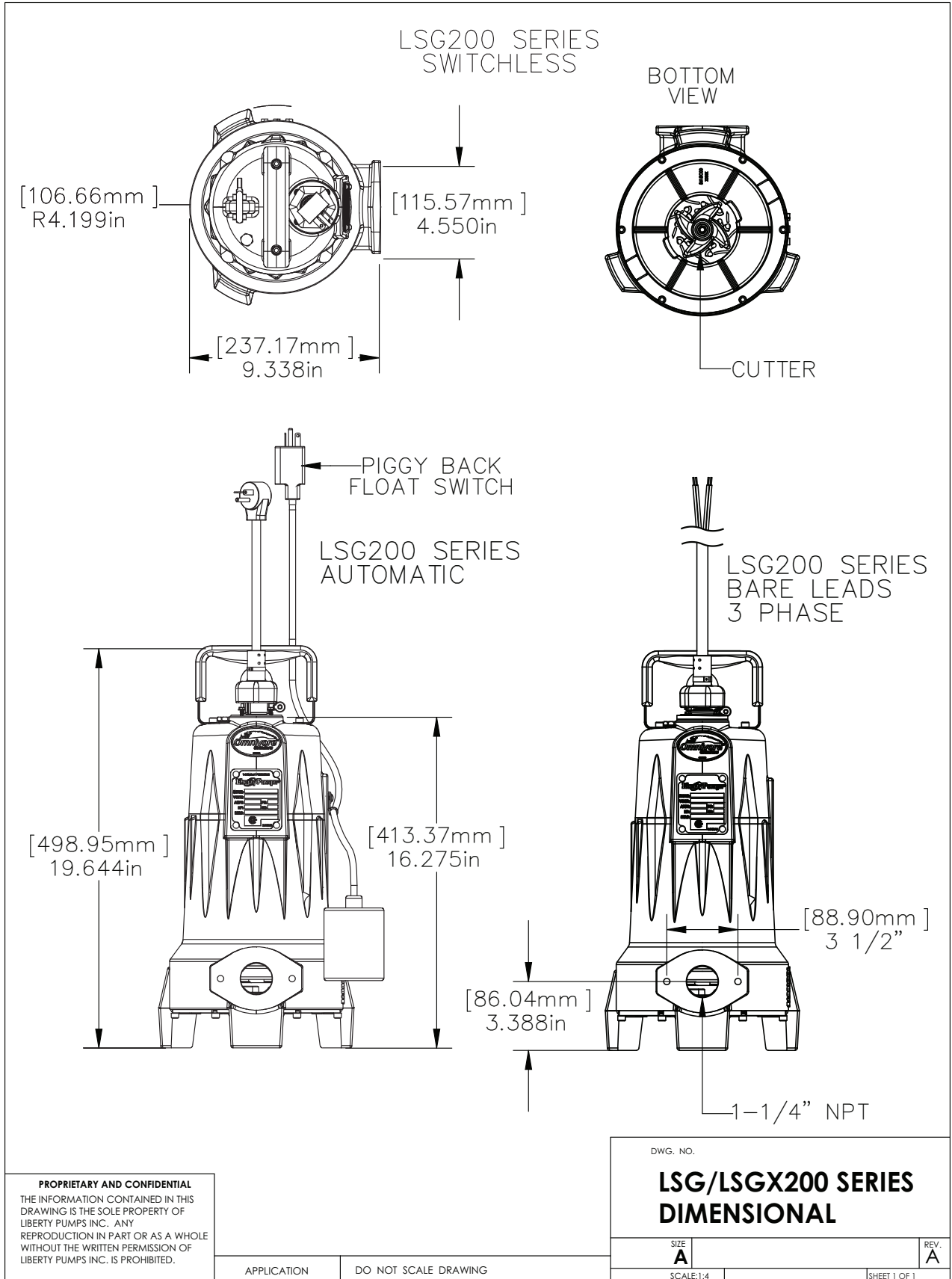

LSG/LSGX-Series Dimensional Data

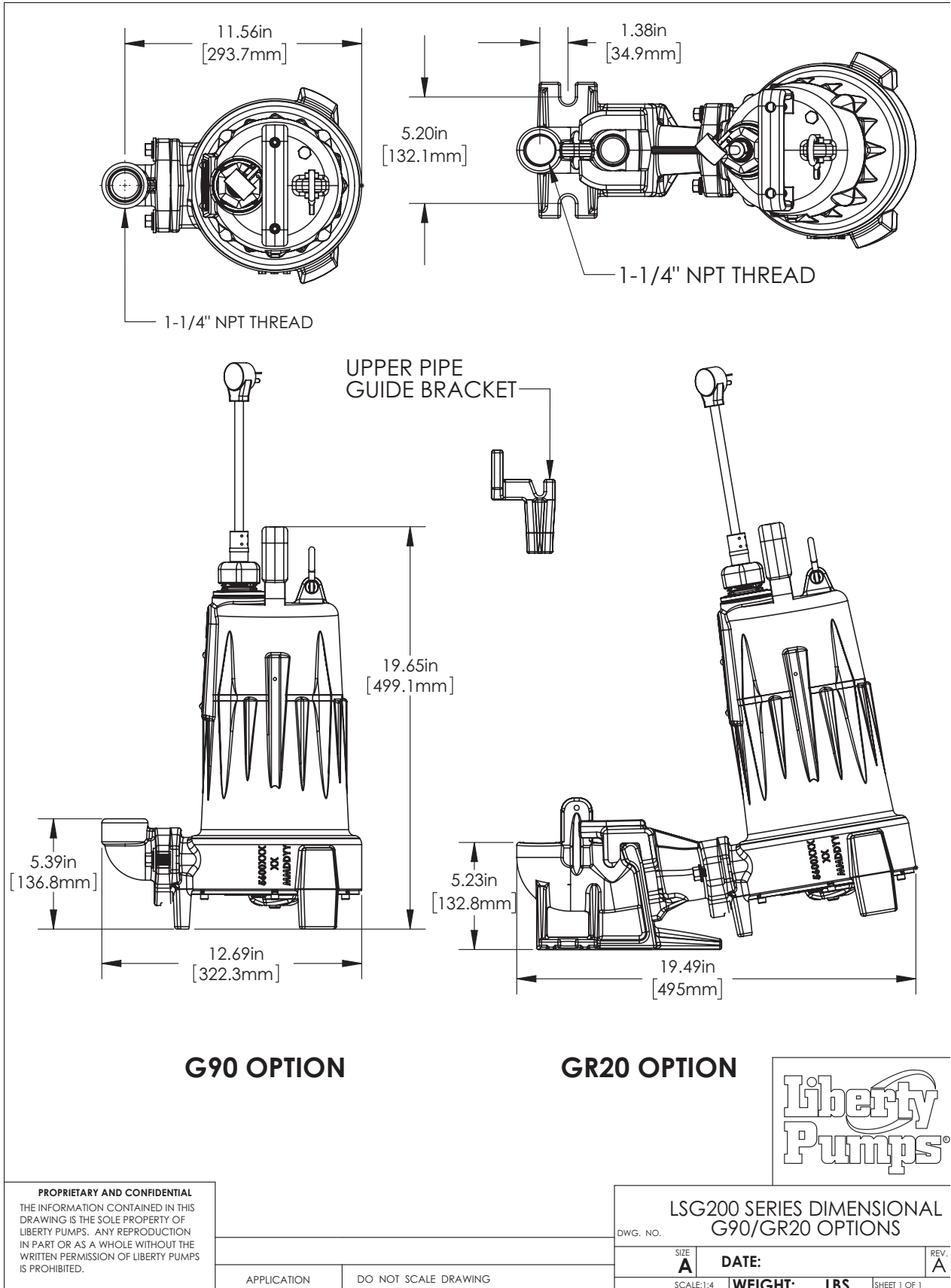

LSG/LSGX-Series Electrical Data

| MODEL | HP | VOLTAGE | PHASE | SF | FULL LOAD AMPS | LOCKED ROTOR AMPS | THERMAL OVERLOAD TEMP | STATOR WINDING CLASS | CORD LENGTH OPTIONS [FT] | DISCHARGE | AUTOMATIC |
|-------------------------|----|---------|-------|-----|----------------|-------------------|-----------------------|----------------------|--------------------------|---------------------|-----------|
| LSG202A | 2 | 208/230 | 1 | 1.0 | 15 | 53 | 105°C (221°F) | B | 25 | 1-1/4" NPT + FLANGE | YES |
| LSG202M | 2 | 208/230 | 1 | 1.0 | 15 | 53 | 105°C (221°F) | B | 25/35/50 | 1-1/4" NPT + FLANGE | NO |
| LSG202M-C ¹ | 2 | 208/230 | 1 | 1.0 | 15 | 53 | 135°C (275°F) | B | 35/50 | 1-1/4" NPT + FLANGE | NO |
| LSG203M | 2 | 208/230 | 3 | 1.0 | 10.6 | 61 | N/A | B | 25/35/50 | 1-1/4" NPT + FLANGE | NO |
| LSG204M | 2 | 440-480 | 3 | 1.0 | 5.3 | 31 | N/A | B | 25/35/50 | 1-1/4" NPT + FLANGE | NO |
| LSG205M | 2 | 575 | 3 | 1.0 | 4.9 | 31 | N/A | B | 25/35/50 | 1-1/4" NPT + FLANGE | NO |
| LSGX202A | 2 | 208-230 | 1 | 1.0 | 15 | 53 | 135°C (275°F) | B | 25 | 1-1/4" NPT + FLANGE | YES |
| LSGX202M | 2 | 208-230 | 1 | 1.0 | 15 | 53 | 135°C (275°F) | B | 25/35/50 | 1-1/4" NPT + FLANGE | NO |
| LSGX202M-C ¹ | 2 | 208-230 | 1 | 1.0 | 15 | 53 | 135°C (275°F) | B | 35/50 | 1-1/4" NPT + FLANGE | NO |
| LSGX203M | 2 | 208/230 | 3 | 1.0 | 10.6 | 61 | N/A | B | 25/35/50 | 1-1/4" NPT + FLANGE | NO |
| LSGX204M | 2 | 440-480 | 3 | 1.0 | 5.3 | 31 | N/A | B | 25/35/50 | 1-1/4" NPT + FLANGE | NO |
| LSGX205M | 2 | 575 | 3 | 1.0 | 4.9 | 31 | N/A | B | 25/35/50 | 1-1/4" NPT + FLANGE | NO |

¹ LSG202M-C and LSGX202M-C are for external capacitor applications and require the use of control panels fitted with properly matched capacitors and start relays. Consult Liberty Pumps catalog for proper panel model when ordering. For retrofit applications, order Liberty Pumps Start Kit #K001316 which includes the correct Start Capacitor, Run Capacitor, and Potential Start Relay. In all cases, control panels must be constructed per applicable UL and/or CSA standards and be installed per NEC.

LSG/LSGX-Series Technical Data

| | |
|----------------------------|--|
| IMPELLER | 300 SERIES STAINLESS STEEL |
| PAINT | POWDER COAT |
| MAX LIQUID TEMP | 60°C (140°F) |
| MAX STATOR TEMP (1-PHASE) | LSG202A, LSG202M, AND LSG202M-3 – 105°C (221°F) LSG202M-C AND ALL LSGX MODELS – 135°C (275°F) |
| THERMAL OVERLOAD (1-PHASE) | LSG202A, LSG202M, AND LSG202M-3 – 105°C (221°F) LSG202M-C AND LSGX MODELS – 135°C (275°F) |
| POWER CORD TYPE | SJOOW (1-phase) SEOOW (3-phase) SOOW (external capacitor models) |
| MOTOR HOUSING | CLASS 25 CAST IRON |
| VOLUTE | CLASS 25 CAST IRON |
| SHAFT | 300 SERIES STAINLESS STEEL |
| HARDWARE | STAINLESS |
| O-RINGS | BUNA-N |
| MECHANICAL SEAL | UNITIZED SILICON CARBIDE |
| MIN BEARING LIFE | 50,000 HRS |
| WEIGHT | LSG 85 LBS/38.5 KG LSGX 95 LBS/43 KG |

LSG200/LSGX200-Series Specifications

1.01 GENERAL

The contractor shall provide labor, material, equipment, and incidentals required to provide _____ (QTY) centrifugal grinder pumps as specified herein. The pump models covered in this specification are LSG200/LSGX200-Series single/three-phase grinder pumps. The pump furnished for this application shall be model _____ as manufactured by Liberty Pumps.

2.01 OPERATING CONDITIONS

Each submersible pump shall be rated at 2 hp, _____ volts, _____ phase, 60 Hz, 3450 RPM. The unit shall produce _____ GPM at _____ feet of total dynamic head.

The submersible pump shall be capable of handling residential and commercial sewage and grinding it to a fine slurry enabling it to be pumped over long distances in pipelines as small as 1.25" in diameter. The LSG-Series single-stage submersible pump shall have a shut-off head of 110 feet and a maximum flow of 50 GPM @ 10 feet of total dynamic head. The LSGX-Series 2-stage submersible pump shall have a shut-off head of 185 feet and a maximum flow of 38 GPM @ 10 feet of total dynamic head.

Single-phase pumps shall have capacitors and start relay mounted [] in the pump, or [] in the panel.

The pump shall be controlled with:

- _____ A piggyback style on/off float switch (single-phase only)
- _____ A NEMA 4X outdoor simplex control panel with three float switches and a high water alarm
- _____ A NEMA 1 indoor simplex control panel with three float switches and a high water alarm
- _____ A NEMA 4X outdoor duplex control panel with three float switches and a high water alarm
- _____ A NEMA 1 indoor duplex control panel with three float switches and a high water alarm
- _____ A NEMA 4X outdoor duplex control panel with four float switches and a high water alarm
- _____ A NEMA 1 indoor duplex control panel with four float switches and a high water alarm

3.01 CONSTRUCTION

Each centrifugal grinder pump shall be equal to the  certified LSG/LSGX-Series grinder pumps as manufactured by Liberty Pumps, Bergen NY. The castings shall be constructed of class 25 cast iron. The motor housing shall be oil filled to dissipate heat. Air filled motors shall not be considered equal since they do not properly dissipate heat from the motor. All mating parts shall be machined and sealed with a Buna-N O-ring. All fasteners exposed to the liquid shall be stainless steel. The motor shall be protected on the top side with sealed cord entry plate with molded pins to conduct electricity eliminating the ability of water to enter internally through the cord. The motor shall be protected on the lower side with a dual seal arrangement. The first seal is a double lip seal molded in fluoroelastomer. The second/main seal shall be a unitized hard face silicon carbide seal with stainless steel housings and spring.

The upper and lower bearing shall be capable of handling all radial thrust loads. The lower bearing shall have the additional ability to handle the downward axial thrust produced by the impeller and cutters by design of angular contact roller races. The pump housing shall be of the concentric design thereby equalizing the pressure forces inside the housing which will extend the service life of the seals and bearings. Additionally there shall be no cutwater in the housing volute in order to discourage the entrapment of flowing debris. The pump shall be furnished with a stainless steel handle having a nitrile grip.

4.01 ELECTRICAL POWER CORD

The submersible pumps shall be supplied with 25 feet of multi-conductor power cord (35 feet for external capacitor models). It shall be cord type SJOOW (1-phase), SEOOW (3-phase), or SOOW (external capacitor models), capable of continued exposure to the pumped liquid. The power cord shall be sized for the rated full load amps of the pump in accordance with the National Electric Code. The power cable shall not enter the motor housing directly but will conduct electricity to the motor by means of a watertight compression fitting cord plate assembly with molded pins to conduct electricity. This will eliminate the ability of water to enter internally through the cord via a damaged or wicking cord.

5.01 MOTORS

All motors shall be oil filled and class B insulated NEMA B design rated for continuous duty. Since air filled motors are not capable of dissipating heat as effectively, they shall not be considered equal. Single-phase motors shall be capacitor start/capacitor run and have an integral thermal overload switch in the windings for protecting the motor. Three-phase motors shall be used with an appropriate controller with integral overload protection. On all single-phase models (excluding LSG202M-C and LSGX202M-C), the capacitor circuit shall be mounted internally and motors shall have an integral solid state starting circuit switch for switching the start winding off.

6.01 BEARINGS AND SHAFT

An upper radial and a lower angular contact ball bearing shall be required. The upper bearing shall be a single ball/race type bearing. The lower bearing shall be an angular contact heavy-duty ball/race type bearing, designed to handle axial grinder pump thrust loads. Both bearings shall be permanently lubricated by the oil, which fills the motor housing. The bearing system shall be designed to enable proper cutter alignment from shut off head to maximum load at 10 feet of TDH. The motor shaft shall be made of 300 series stainless steel and have a minimum diameter of 0.670".

7.01 SEALS

The pump shall have a dual seal arrangement consisting of a lower and upper seal to protect the motor from the pumping liquid. The lower seal shall be a fluoroelastomer molded double lip seal designed to exclude foreign material away from the main upper seal. The upper seal shall be a unitized silicon carbide hard face seal with stainless steel housings and spring equal to Crane Type T-6a. The motor plate/housing interface shall be sealed with a Buna-N O-ring.

8.01 IMPELLER

The impeller shall be an investment cast stainless steel impeller with pump out vanes on the back shroud to keep debris away from the seal area. It shall be keyed and bolted to the motor shaft.

9.01 CUTTER MECHANISM

The cutter and plate shall consist of 440 stainless steel with a Rockwell C hardness of 55–60. The stationary cutter plate shall have specially designed orifices through it, which enable the slurry to flow through the pump housing at an equalized pressure and velocity. The stationary cutter shall consist of V shapes to maximize cutting action and arc shape exclusion slots to outwardly eject debris from under the rotary cutter. The rotary cutter shall have (4) blades and be designed with a recessed area behind the cutting edge to prevent the accumulation and binding of any material between rotary cutter and the stationary cutter. The cutting system must incorporate close tolerances for optimum performance. Ring or radial cutters, or those that grind on the outside circumference, shall not be considered equal.

10.01 CONTROLS

Select single-phase units (excluding external capacitor models) can be supplied with CSA and UL approved automatic wide angle tilt float switches. The switches shall be equipped with piggyback style plug that allows the pump to be operated manually without the removal of the pump in the event that a switch becomes inoperable. Manual pumps are operable by means of a pump control panel.

11.01 PAINT

The exterior of the casting shall be protected with powder coat paint.

12.01 SUPPORT

The pump shall have cast iron support legs enabling it to be a freestanding unit. The legs will be high enough to allow solids and long stringy debris to enter the cutter assembly.

13.01 SERVICEABILITY

Components required for the repair of the pump shall be shipped within a period of 24 hours.

14.01 FACTORY ASSEMBLED TANK SYSTEMS WITH GUIDE RAIL AND QUICK DISCONNECT DISCHARGE

- Factory mounted guide rail system with pump suspended by means of bolt-on quick disconnect that is sealed by means of nitrile grommets. The discharge piping shall be schedule 80 PVC and furnished with a check valve and PVC shut-off ball valve. The tank shall be wound fiberglass or roto-molded plastic. An inlet hub shall be provided with the system.
- Stainless steel guide rail
- Zinc plated steel guide rail
- " diameter of basin size
- " height of basin size
- " distance from top of tank to discharge pipe outlet
- Fiberglass cover
- Structural foam polymer cover
- Steel cover
- Simplex system with outdoor panel and alarm
- Duplex system with outdoor panel and alarm
- Separate outdoor alarm
- Remote outdoor alarm

15.01 TESTING

The pump shall have a ground continuity check and the motor chamber shall be hi-potted to test for electrical integrity, moisture content and insulation defects. The motor and volute housing shall be pressurized, and an air leak decay test performed to ensure integrity of the motor housing. The pump shall be run, voltage current monitored, and checked for noise or other malfunction.

16.01 QUALITY CONTROL

The pump shall be manufactured in an ISO 9001 certified facility.

17.01 WARRANTY

Standard limited warranty shall be 3 years.